

Assembly and operating instructions

Dulcodes A

UV system



Certified to
NSF/ANSI Standard 50

EN

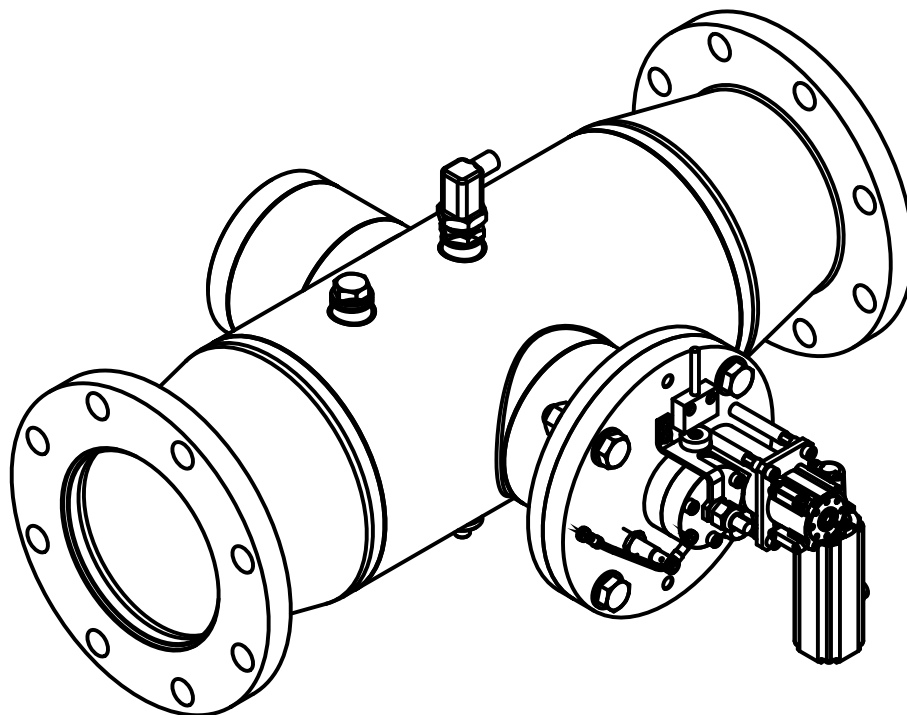

A1144

Please stick the nameplate here

Target group: at least "instructed personnel" unless otherwise required.

**Please carefully read these operating instructions before use. · Do not discard.
The operator shall be liable for any damage caused by installation or operating errors.
The latest version of the operating instructions are available on our homepage.**

General non-discriminatory approach

In order to make it easier to read, this document uses the male form in grammatical structures but with an implied neutral sense. The document is always aimed equally at women, men and gender-neutral persons. We kindly ask readers for their understanding in this simplification of the text.

Supplementary information

➔ Please read the supplementary information in its entirety.

Information



This provides important information relating to the correct operation of the unit or is intended to make your work easier.

Warning information

Warning information includes detailed descriptions of the hazardous situation, see  *Chapter 3.1 'Labelling of Warning Information' on page 10.*

The following symbols are used to highlight instructions, links, lists, results and other elements in this document:

Tab. 1: More symbols

Symbol	Description
1. ➔	Action, step by step.
⇒	Outcome of an action.
	Links to elements or sections of these instructions or other applicable documents.
■	List without set order.
[Button]	Display element (e.g. indicators). Operating element (e.g. button, switch).
'Display/GUI'	Screen elements (e.g. buttons, assignment of function keys).
CODE	Presentation of software elements and/or texts.

Table of contents

1	About this system	5
1.1	Correct and Proper Use	5
2	General information and operating concept	6
2.1	Entering data on the KP300 Basic.....	7
3	Safety chapter	10
3.1	Labelling of Warning Information.....	10
3.2	User qualification.....	12
3.3	Dulcodes safety information.....	13
3.4	Safety equipment.....	14
3.5	Information in the Event of an Emergency	14
4	Permissible ambient conditions	15
5	Function	16
5.1	Commissioning.....	16
5.2	Normal mode.....	17
5.3	Controlled operation.....	17
5.4	Automatic wiper.....	17
5.5	Temperature Monitoring	17
5.6	Switching off.....	18
5.7	Cool down.....	18
5.8	Behaviour should the supply voltage fail.....	18
6	Control	19
6.1	Version.....	19
6.2	Display of UV dose and radiation intensity (UV intensity).....	20
6.3	Adjusting the Dulcodes A control.....	20
6.4	Display.....	23
6.4.1	Functions of the keys in <i>[Unit Off]</i> status	23
6.4.2	Functions of the keys in <i>[PAUSE]</i> status	24
6.4.3	Functions of the keys in <i>[COOLING]</i> status	26
6.4.4	Functions of the keys in <i>[Startup]</i> status	27
6.4.5	The function of the keys in <i>[Commissioning rinse]</i> mode.....	28
6.4.6	Functions of keys in <i>[Free rinse]</i> mode.....	29
6.4.7	The function of the keys in <i>[Normal operation]</i> mode.....	31
6.4.8	The function of the keys in <i>[Post-burning]</i> status.....	32
6.4.9	The function of the keys in <i>[Fault]</i> status	33
6.4.10	Control of the automatic wiper.....	34
6.5	Menu.....	35
6.5.1	The first operating and display level.....	35
6.5.2	The second operating and display level.....	38
6.5.3	The third operating and display level.....	45
7	Assembly and installation	50
7.1	Installation details	51
7.2	Radiation chamber.....	53
7.2.1	Assembly.....	53
7.2.2	Attach the warning label.....	54
7.2.3	Hydraulic Connections	54
7.3	Control cabinet and control.....	55

7.3.1	Assembly	55
7.3.2	Electrical connections.....	55
7.3.3	Fitting the temperature sensor.....	55
7.4	Fitting the UV lamp protection tube.....	56
7.4.1	Fitting the UV lamp protection tube with automatic wiper.....	56
7.5	Assembly and connection of the UV lamp.....	56
7.6	Assembly and installation of the wiper motor.....	58
8	Commissioning.....	59
8.1	Check the control system programming.....	59
8.2	Leak testing and ventilation of the reactor.....	60
8.3	Switching on the UV system.....	60
9	Maintenance.....	61
9.1	Maintaining and caring for the KP 300.....	62
9.2	Cleaning.....	63
9.2.1	Cleaning the UV lamp protection tube.....	63
9.2.2	Cleaning after dismantling the UV lamp protection tube.....	64
9.2.3	Cleaning with Cleaning Solution by Filling the UV System.....	66
9.2.4	Cleaning the UV Sensor	67
9.3	Maintenance of the wearing parts.....	68
9.3.1	Tools.....	68
9.3.2	Replacing wearing parts after an operating period of one year.....	69
9.3.3	Instructions: Replacing the wearing parts	69
9.4	Replacing the lamp.....	89
9.5	Calibration of the UV sensor.....	91
9.5.1	<i>[Sensor calibration]</i>	92
9.6	Replacing the Filter Mats.....	92
10	Troubleshooting.....	94
11	Technical data.....	98
11.1	Dimensions Sheet.....	100
11.2	Electrical data.....	104
12	Appendix.....	105
12.1	Spare parts 1 kW - 3 kW.....	105
12.2	Spare parts for 2x2 kW, 2x3 kW, 3x3 kW multiple lamp system.....	109
12.3	UV system operating log.....	111
12.4	Disposal of used parts.....	112
12.5	Declaration of Conformity.....	113
13	Index.....	114

1 About this system

Application

Dulcodes A UV systems are used for disinfection and to support the disinfection of:

- Potable water
- Process water
- Swimming pool water

In the treatment of swimming pool water, harmful substances, such as chloramines, can be effectively reduced by UV radiation and also germs, which are difficult to combat with chlorine, can be safely killed. UV radiation is proven for the reduction of inorganic combined chlorine. Organically bound chlorine is generally more stable and cannot be reduced by UV radiation.

Dulcodes UV systems are supplied ready for connection. They are available in different designs, defined by their identity code. The performance data can be found in the data sheet enclosed with the Dulcodes UV system.

Scope of supply:

- Radiation chamber
- Lamp with lamp protection tube
- UV-C sensor
- Temperature switch
- Automatic wiper
- Control cabinet with control
- Documentation

1.1 Correct and Proper Use



Correct and Proper Use

The operator is liable for damage caused by installation and operating errors!

- *The system is intended solely for the treatment of water.*
- *The system may only be used in accordance with the technical data and specifications outlined in the operating instructions!*
- *Any other use or modification of the system is prohibited.*
- *The system may only be operated by trained and authorised personnel!*
- *It is imperative that the information in the operating instructions relating to the different phases of the unit's service life is observed!*

2 General information and operating concept

General information



Display background lighting

To ensure easy monitoring of the UV system operation, the background lighting of the display changes according to the UV system operating status.

- Normal operation: green lighting
- Warning: yellow lighting
- Fault: red lighting

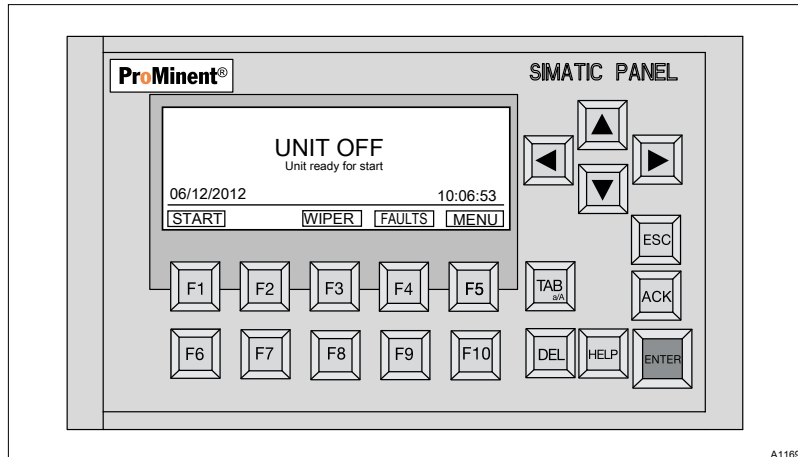

Fig. 1: Status [UNIT OFF]

In operation, as well as in the [UNIT OFF] status, you can change to the [menu] by pressing [F5]. The [menu] contains additional information about statuses, settings and system history.

Alongside this information, the menu area is also used to adjust the control.

If no key is pressed for 5 minutes, then the UV system automatically exits the [menu] and the standard display for the current operating status is displayed.

The [menu] is set to the corresponding operating statuses, that is to say when the UV system is running, all events are monitored and treated accordingly to the operating status, but are not displayed. If, due to events, the control changes to one of the statuses [POST-BURNING], [PAUSE], [RINSE] or [FAULT] the system exits the [menu] and the display corresponding to the operating status appears.

The operating concept



The function keys F1 ... F10

Essentially the arrow keys and the [TAB] key can be used as an alternative to the function keys [F1] ... [F10]. These operating instructions describe operation of the system using the function keys [F1] ... [F10] as a matter of course. Use of the arrow keys and the [TAB] key is only described where this is unavoidable.

This approach should improve the legibility and ease of understanding of the operating instructions.

You can call up the individual functions using the function keys [F1] ... [F5].

Overview

The KP300 Basic is equipped with system keys. The system keys are subdivided as follows:

- Control keys
- Function keys with integrated alphanumeric keys

Tab. 2: The following table outlines the function and effect of the operating device control keys

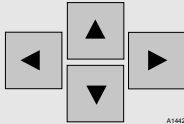
Key	Function	Effect
	Move cursor	Operating objects: Activates the next operating object in the respective direction Entry: Moves the cursor in the relevant direction List: Selects the next list entry.
ENTER	Confirm or activate	Menu: Executes the selected command. Entry: Confirms and ends entry. List: Activates the operation
ESC	Cancels operation	Value entry: Resets the original value. Window: Closes the window without applying a change. Help: Closes help and returns to the previous view.
ACK	Acknowledge message	Depending on the project planning, closes the message currently displayed or selected or all the messages in an acknowledged group.
DEL	Delete character	Deletes the character at the cursor position. The following characters are shifted one position to the left.
HELP	Display help text	Displays the planned help text for the selected operating object. If no help text is planned, no help is displayed.
TAB	Switch between upper case and lower case	Switches between upper case and lower case when inputting text. The following characters are then typed either all in upper case or all in lower case.
TAB	Select next operating object	Selects the next operating object in the project within the planned TAB sequence.

2.1 Entering data on the KP300 Basic

Introduction

The function keys of the KP300 Basic have the same operating concept as the keypad of a mobile phone. Each function key has multiple assignments with the letters of the alphabet and special characters as well as each being allocated a number. When inputting a value, the available characters are displayed in a menu on the display. Each time a function key is pressed, the selection in the menu moves to the right. At the end the selection jumps back to the start.

Numerical and alphanumeric assignment always has the following sequence when values are being entered:

- Letters, e.g. JKL
- Number e.g. 5
- Special characters and umlauts (optional)

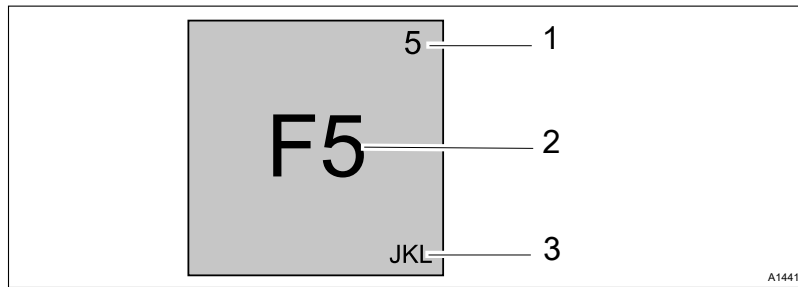

Fig. 2: The figure shows the assignment for the function key [F5].

1. Numerical assignment; automatically active when inputting numerical values
2. Function assignment is disabled if you use [ENTER] in the control panel of project to switch to editing mode. Instead, the numerical and / or alphanumerical assignment is activated. Simultaneously a message is emitted that the function keys are disabled.
3. Alphabetical assignment; automatically active when alphanumerical values are entered. Numerical assignment is also available. When entering hexadecimal values, only the alphanumerical assignment of keys [A] to [F] plus numerical assignment are active

On the KP300 Basic, you either move within the menu or operate the current project.

Menu operation

Proceed as follows:

1. To move around in the menu of the KP300 Basic, use the cursor keys or press [TAB]
⇒ Highlighting is shifted to the corresponding menu entry.
2. To execute a menu command, press [ENTER]
⇒ The next menu level is displayed.
3. If a menu level contains an input field, use the function keys to enter the corresponding value.
4. If a menu level contains a list:
 - Press [ENTER] to activate operation of the list
 - Use the cursor keys to switch between the list entries.
 - Press [ENTER] to select a list entry
5. To enter a value in the menu:
 - Press [ENTER] to accept a value
 - Press [ESC] to discard a value or return to the overlying menu
 - Press [Del] to delete a value

Entering numbers and characters

Use the function keys to enter numbers and characters.

Proceed as follows:

1. Activate operation of the operating object.
2. Press the corresponding key until the desired character is shown on the screen.

Depending on the format of the operating object, you can limit the assignment of the function keys to letters or numbers.

The desired characters are applied after approximately one second or immediately after pressing another key.

3. ➤ Use the cursor keys to navigate within the entered character chain.
4. ➤ Apply the entry with *[ENTER]*

Limit value checking with numerical values

You can plan limit values for variables. If you enter a value that is outside these limits, the value is not applied. If a message window has been planned for the project, a system message is emitted and the original value is displayed again.

3 Safety chapter

3.1 Labelling of Warning Information

Introduction

These operating instructions provide information on the technical data and functions of the product. These operating instructions provide detailed warning information and are provided as clear step-by-step instructions.

The warning information and notes are categorised according to the following scheme. A number of different symbols are used to denote different situations. The symbols shown here serve only as examples.



DANGER!

Nature and source of the danger

Consequence: Fatal or very serious injuries.

Measure to be taken to avoid this danger.

Description of hazard

- Denotes an immediate threatening danger. If the situation is disregarded, it will result in fatal or very serious injuries.



WARNING!

Nature and source of the danger

Possible consequence: Fatal or very serious injuries.

Measure to be taken to avoid this danger.

- Denotes a possibly hazardous situation. If the situation is disregarded, it could result in fatal or very serious injuries.



CAUTION!

Nature and source of the danger

Possible consequence: Slight or minor injuries.
Material damage.

Measure to be taken to avoid this danger.

- Denotes a possibly hazardous situation. If the situation is disregarded, it could result in slight or minor injuries. May also be used as a warning about material damage.



NOTICE!

Nature and source of the danger

Damage to the product or its surroundings.

Measure to be taken to avoid this danger.

- Denotes a possibly damaging situation. If the situation is disregarded, the product or an object in its vicinity could be damaged.



Type of information

Hints on use and additional information.

Source of the information. Additional measures.

- *Denotes hints on use and other useful information. It does not indicate a hazardous or damaging situation.*

3.2 User qualification



WARNING!

Danger of injury with inadequately qualified personnel

The operator of the system / equipment is responsible for ensuring that the qualifications are fulfilled.

If inadequately qualified personnel work on the unit or loiter in the hazard zone of the unit, this could result in dangers that could cause serious injuries and material damage.

- All work on the unit should therefore only be conducted by qualified personnel.
- Unqualified personnel should be kept away from the hazard zone.

The pertinent accident prevention regulations, as well as all other generally acknowledged safety regulations, must be adhered to.

Training	Definition
Instructed personnel	An instructed person is deemed to be a person who has been instructed and, if required, trained in the tasks assigned to him and possible dangers that could result from improper behaviour, as well as having been instructed in the required protective equipment and protective measures.
Trained user	A trained user is a person who fulfils the requirements made of an instructed person and who has also received additional training specific to the system from the manufacturer or another authorised distribution partner.
Trained, qualified personnel	A trained, qualified employee is deemed to be a person who is able to assess the tasks assigned to him and recognize possible hazards based on his training, knowledge and experience, as well as knowledge of pertinent regulations. A trained, qualified employee must be able to perform the tasks assigned to him independently with the assistance of drawing documentation and parts lists. The assessment of a person's technical training can also be based on several years of work in the relevant field.
Electrical technician	An electrical technician is able to complete work on electrical systems and recognise and avoid possible dangers independently based on his technical training and experience as well as knowledge of pertinent standards and regulations. An electrical technician must be able to perform the tasks assigned to him independently with the assistance of drawing documentation, parts lists, terminal and circuit diagrams. The electrical technician must be specifically trained for the working environment in which the electrical technician is employed and be conversant with the relevant standards and regulations.
Service	The Service department refers to service technicians, who have received proven training and have been authorised by the manufacturer to work on the system.

3.3 Dulcodes safety information



WARNING!
UV-C radiation

Possible consequence: Serious injuries

UV-C radiation is harmful to the eyes and skin

- Only operate the UV lamp  when it is fully fitted and installed
- Install the UV lamp into the UV system in accordance with the regulations prior to commissioning



WARNING!
Live parts!

Possible consequence: Fatal or very serious injuries

- Measure: Disconnect the device from the power supply before opening it.
- Disconnect damaged and defective devices or devices that have been tampered with from the power supply



WARNING!
Insufficient water treatment

Possible consequence: Illness or disease

Please read the technical data sheet for your UV system

Ensure that:

- the maximum permissible water flow rate is not exceeded and
- the UV transmission does not fall below the permissible level,
 - as otherwise adequate treatment of the water cannot be guaranteed.



CAUTION!
Overheating of lamp and treatment chamber

Possible consequence: Material damage

- Ensure that, with the exception of when the UV lamp is warming up, the radiation chamber has a flow rate of at least 5% of the nominal flow rate, so that the radiation chamber cannot overheat.
- Only switch on the UV system after the radiation chamber has been filled with water.
- Switch the UV system off if the flow of water is interrupted.



CAUTION!

Unauthorised operating parameters

Possible consequence: Material damage

Ensure that:

- The installation place is dry and frost-free
- There is guaranteed protection for the UV system from chemicals, dyes and vapours
- The ambient temperature and the radiation temperature in the direct vicinity of the system do not exceed 40°C
- The maximum permissible operating pressure is not exceeded and
- There are no solid particles and no turbidity in the water to be treated
- If necessary, fit a suitable filter prior to the UV system.

3.4 Safety equipment

Labels on reactor

ATTENTION: Hazardous ultraviolet radiation

⚠ UV-C radiation is harmful to the eyes and skin! The UV lamps may only be operated when installed. The UV system should be installed in accordance with all pertinent regulations prior to commissioning the UV lamps.

ATTENTION: Hazard

⚠ Disconnect the system from the mains power supply or switch off the master switch prior to commencing maintenance work. Depressurise the reactor prior to commencing maintenance work.

Labels on control cabinet

⚠ Disconnect the system from the mains power supply or switch off the master switch prior to opening.

3.5 Information in the Event of an Emergency

In the event of an emergency, switch the red-yellow main switch on the side of the control cabinet to OFF or disconnect from the mains power supply.

4 Permissible ambient conditions

During storage

Permissible ambient temperature: - 20 °C ... + 70 °C.

Humidity: maximum 95 % relative air humidity, non-condensing.

Other: No dust, no direct sunlight.

During operation

Permissible ambient temperature: + 5 °C ... + 40 °C.

Humidity: maximum 92 % relative air humidity, non-condensing.

Other ambient conditions: No dust, no direct sunlight. No corrosive gases, vapours and dust.

5 Function

The water to be treated flows through the stainless steel radiation chamber past the UV lamp. UV radiation kills the germs and destroys substances, like chloramines, in the swimming pool water.

The UV medium pressure lamp produces UV-C radiation. The UV lamp is located in a quartz lamp protection tube with good UV transparency.

The design of the radiation chamber and the flow of radiation deliver even irradiation of the entire flow of water.

A control monitors the UV system in conjunction with the UV sensor.

Installation diagram of a UV system



Shut-off valves and rinse valves do not form part of the scope of delivery

The shut-off valves and rinse valves do not form part of the scope of delivery of the UV system and are provided by the operator on site.

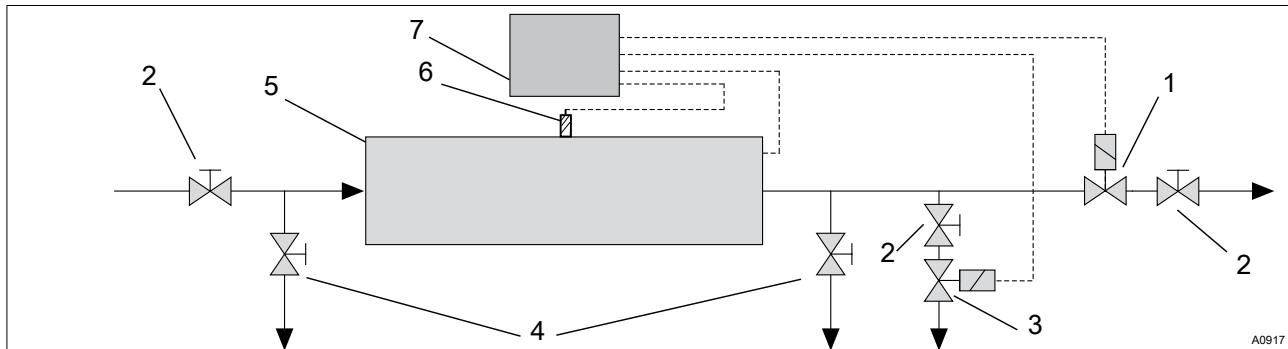

Fig. 3: Typical installation layout for a UV system

- | | |
|----------------------------|-------------|
| 1 Shut-off valve | 5 Reactor |
| 2 Shut-off valve | 6 UV sensor |
| 3 Rinse valve | 7 Control |
| 4 Sampling taps, fireproof | |

5.1 Commissioning

Once the UV system has been switched on, the UV lamp is ignited. Following ignition, the UV lamp requires approximately 1 ... 3 minutes until it has reached its operating temperature.

If the safety threshold is not exceeded within the maximum permissible warm-up time, the controller switches the UV-system off and goes into fault mode.

The UV-C sensor monitors the UV lamp: As soon as the UV output has exceeded the warning threshold, the rinse valve opens for the start rinse.

After the start rinse, the shut-off valve opens and the UV system starts normal operation.

5.2 Normal mode

In normal mode, the UV sensor continues to monitor the UV output:

If the UV output falls below the warning threshold: a warning is emitted.

If the UV output falls below the safety threshold: The shut-off valve, fitted on site, closes, a wiper cycle is triggered and the flushing valve, fitted on site, opens.



The UV system switches off and enters fault mode if the safety threshold is still not exceeded after completion of one wiping cycle.

In this mode, the operator of the UV system has to ensure, for the purpose of disinfecting the water, that the flow of water is reliably interrupted and no unradiated water can be conveyed.

5.3 Controlled operation

UV radiation is automatically adjusted in controlled operation. The UV sensor measures the UV output and forwards the measured UV current value to the control. The UV setpoint is either entered directly in the control (operating mode: control, internal [INT]) or using a variable 4 ... 20 mA standard signal (operating mode: control, external [EXT]).

5.4 Automatic wiper

Manually triggering a wiper cycle



During the wiper process, the warning and safety thresholds are not monitored, consequently the shadowing caused by the wiper does not trigger a false alarm.

If you press the [F3] key [Wiper] in the standard display, then the wiping process is triggered. This is independent of whether the system is 'ON' or 'OFF'.

Regular wiping

If you have activated regular wiping, then a wiping cycle occurs automatically after the set interval has elapsed.

If the interval is set to [0], then regular wiping is deactivated.

5.5 Temperature Monitoring

The water temperature in the radiation chamber is monitored throughout the entire time the UV lamp is operating.

As soon as the water temperature exceeds the maximum temperature, the UV system goes into fault mode.

5.6 Switching off

When the Off button on the UV control is pressed, the UV lamp switches off once the set post-burning time has elapsed. The factory setting is 30 seconds.

If you wish the UV lamp to switch off as soon as you have pressed the off button, then you need to set the post-burning time to 0 seconds.

5.7 Cool down

As the UV lamp can only be re-ignited after switching off of the UV system and sufficient cooling, the system goes into cooling down mode.

During cooling mode, the UV system cannot be started. After the pause status has been cleared during cool-down or *[START]* has been pressed during cooling down, the UV system only restarts after the cooling-down period has ended.

5.8 Behaviour should the supply voltage fail

If the power fails, once the power supply has been reconnected the UV system returns to the operating status in which it was before the power failure.

40 seconds are needed to ramp up the HMI. The PLC (Programmable Logic Controller) is ready for operation considerably faster. To avoid ambiguous operating indicators and operating statuses, operation is only enabled after 45 seconds.

When operation starts, all pending faults are reset if these faults are no longer present. If the wiper is not in the home position, it is moved back. If the power fails while the UV system is in operation, then the system is always cooled down before being started regardless of how long the power failure lasted. The cooling-down phase is not shown on the display, but runs in the background. If the power failure occurs while the UV system is cooling down, the cooling down process is continued after the power has been switched on again.

Should an automatic start not be desirable due to external components, the UV system must be switched from external to pause. External faults result in a UV system fault, which then has to be acknowledged. Separate acknowledgement can thereby be avoided.

6 Control

6.1 Version

As the electronics and software are continually subject to improvements, the version number was introduced as a means of identification. This number should be stated in the event of any complaints. The version number can be called up on the display.

General:

- The UV medium pressure control, based on a S7-1200, is used to monitor and control a medium-pressure UV system one to three medium-pressure lamps.
- The operating and display unit is an HMI KP 300.
- The UV lamps are actuated and monitored via an electronic ballast.
- The UV power is monitored.
- The temperature of the radiation chamber and control cabinet is monitored.
- The wiper is controlled and monitored.
- Several valves can be controlled.
- Several additional inputs and outputs are used to operate the UV system.
- The lamp power can be controlled.
- Operating actions and events are recorded and saved together with the date and time.
 - The data can be displayed in tabular form on the display.
- The radiation intensity or the lamp power is recorded and saved at regular intervals together with the date and time.
 - The radiation intensity can be presented as a simple diagram on the display.

Information for designing a UV system

Varying doses of UV may be necessary depending on the application. Often 600 J/m² is used to reduce combined chlorine and 400 J/m² for disinfection. The UV dose is calculated from the transmission of water and the water flow; refer to the data sheet for your UV system. When calculating the UV dose, in accordance with the data sheet, take into account ageing of the lamp and contamination of the UV system, as well as possible transmission fluctuations in the water quality.

If the transmission of water is not known, it must be calculated when commissioning the UV system and checked with the maximum permissible flow at the desired UV dose. The maximum flow, as stated on the data sheet, must not be exceeded.

Two output levels

The UV system has over two freely adjustable output levels. The control has a digital contact input to switch between these two output levels. You can connect a suitable swimming pool controller to measure the combined chlorine to this digital contact input in swimming pool water treatment. In normal operation, the UV system disinfects with 400 J/m². Should the swimming pool controller measure too high a chloramine value, the UV system is operated at 600 J/m², via the digital contact input, until the chloramine value calls again below the limit value set on the swimming pool controller. This two-stage controller is not used when disinfecting potable water.

6.2 Display of UV dose and radiation intensity (UV intensity)

The UV sensor monitors the radiation intensity of the UV system. The radiation intensity (UV sensor signal) is given in W/m^2 and is displayed on the main screen of the HMI.

The UV dose is calculated depending on the:

- UV transmission,
- flow,
- radiation intensity.

The control calculates the UV dose displayed from this value.

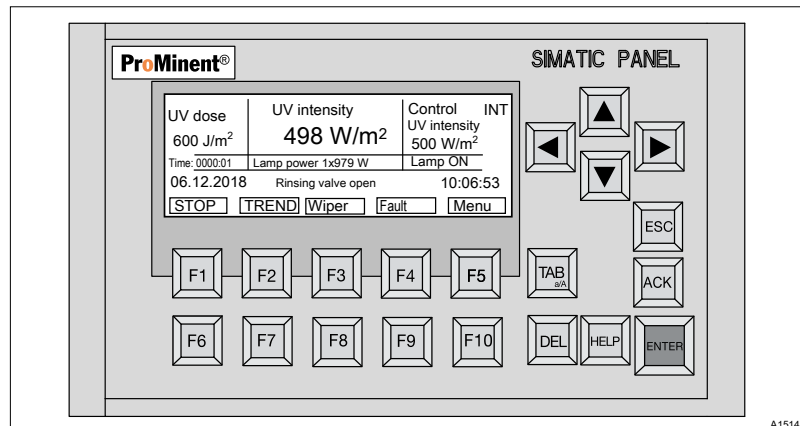

Fig. 4: Display of UV dose and radiation intensity (UV intensity)

In UV systems with connected flow measurement via the 0/4 ... 20 mA input, the current flow appears in the display in turn with the dose display.

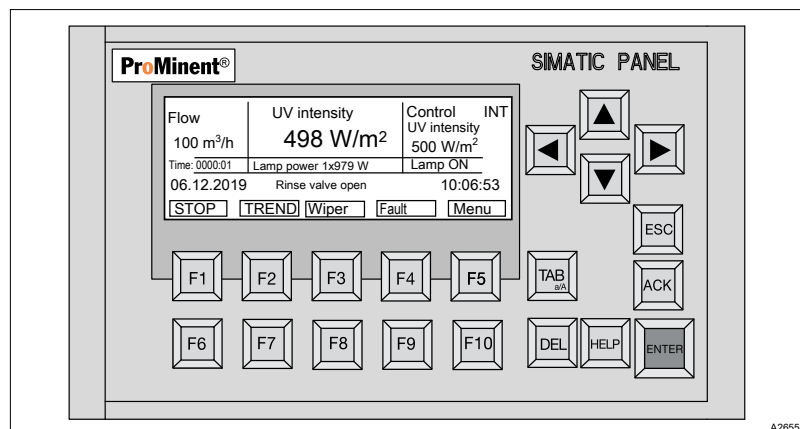

Fig. 5: Display of the current flow [Flow](m^3/h) in turn with the dose display.

6.3 Adjusting the Dulcodes A control



External 4 ... 20 mA signal

In general, the external 4 ... 20 mA signal is produced by a flow meter, to record the flow volume of the system as a control variable for UV control.

	Type of control	Function
1.	[INT] control, constant electrical power:	<p>The system is operated with constant lamp power.</p> <p>Enter a setpoint for the electrical power if using control with constant electrical power. There is no control or adjustment to match varying water quality or flow volume. You can set the lamp power between 40 and 100%, where 40% is the minimum electrical power at which the UV lamp can still be operated safely.</p>
2.	[INT] control, UV sensor signal in W/m ² .	<p>Specify a nominal dose and therefore a setpoint for the UV intensity if using control with constant UV intensity. Control or adjustment is undertaken to match varying water quality. The change in flow volume is not taken into consideration. The smallest achievable UV sensor signal is defined by the possible minimum electrical power of the UV lamp.</p> <p>Once the control parameters have been entered, the UV system calculates the setpoint.</p>
3.	<p>[EXT] control, UV sensor signal:</p> <p>a) UV sensor signal in W/m² depending on the control variable (analogue input signal).</p>	<p>Specify a nominal dose and therefore a setpoint for the UV sensor signal if using [EXT] control, UV sensor signal. Control or adjustment is undertaken to match an analogue input signal. The lamp power is regulated between 40 and 100%, where 40% corresponds to the minimum electrical power at which the UV lamp can still be safely operated.</p> <p>The sensor signal is controlled in proportion to the volumetric flow. Effects of lamp ageing or changes in water quality are compensated for in this way and the radiation dosage is kept constant.</p>

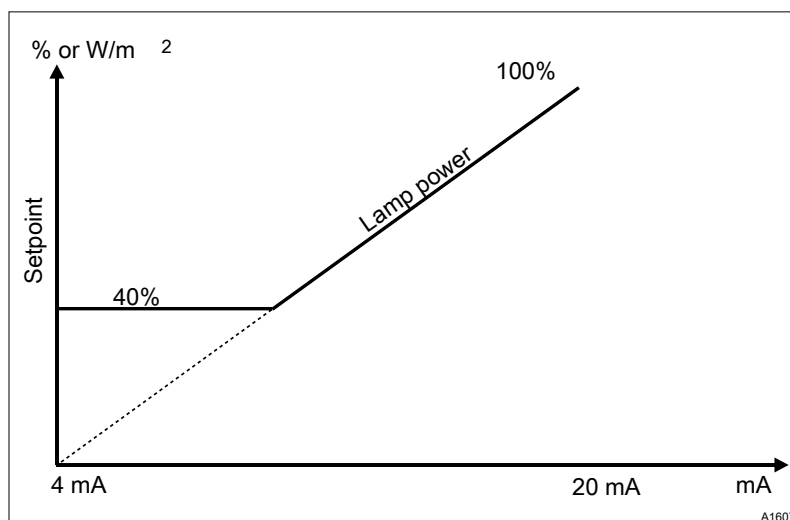

Fig. 6: External [EXT] control

% The percentage (%) of the electrical power or the UV sensor signal.

mA The control variable as mA.

40 % 40% corresponds to the minimum electrical power at which the UV lamp can still be operated safely.

[INT] control, constant electrical power of the UV lamp

The display corresponds to the control as a % of the maximum power of the UV lamps.

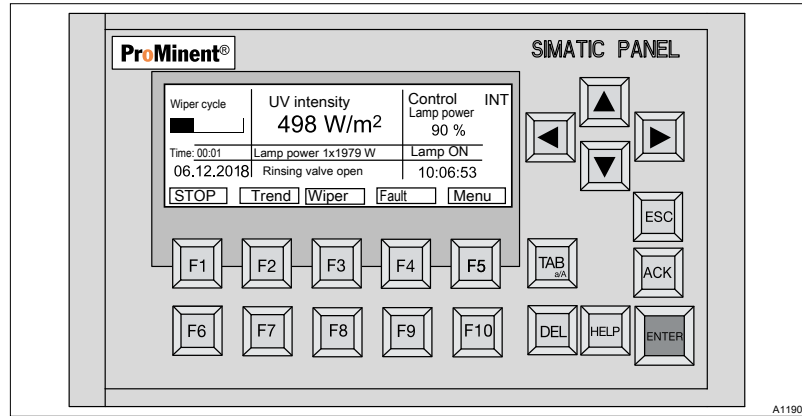

Fig. 7: [INT], constant electrical power

[INT] control, UV sensor signal in W/m²

The display corresponds to the control in W/m² based on the UV sensor signal.

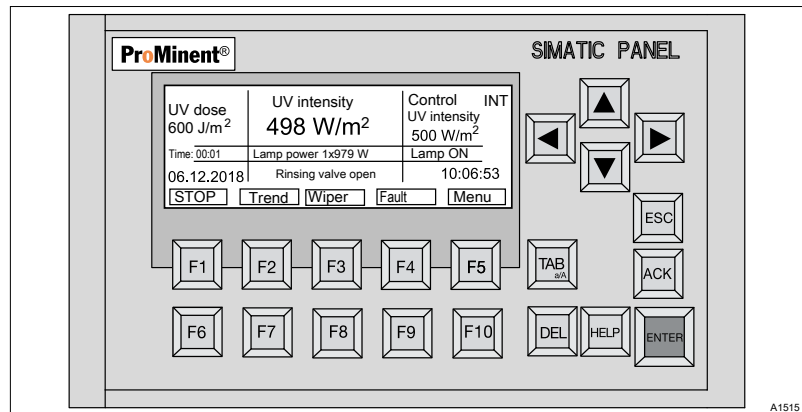

Fig. 8: [INT] control, UV sensor signal in W/m² of the maximum UV sensor signal

[EXT] control, UV sensor signal

The display corresponds to the control in W/m² based on the UV sensor signal.

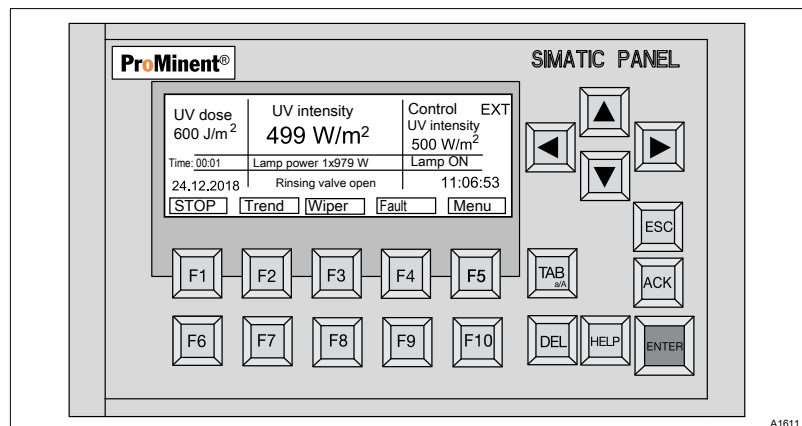

Fig. 9: [EXT] control, UV sensor signal

6.4 Display

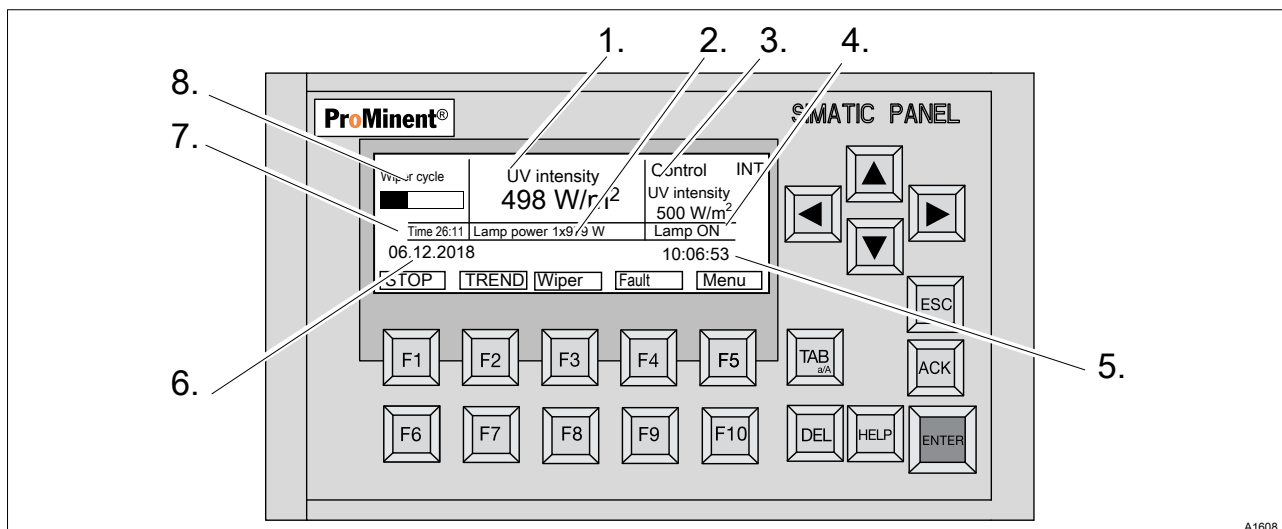

Fig. 10: The display and operating unit of the UV system.

- | | |
|---|---|
| 1. UV intensity (sensor signal) in W/m^2 . | 5. Time. |
| 2. Actual current power consumption of the UV lamp. | 6. Date. |
| 3. Set control mode/setpoint specification. | 7. The operating time since last switched-on. |
| 4. Operating status of the UV lamp. | 8. Information on the wiping cycle, rinsing processes, UV dose, flow. |

6.4.1 Functions of the keys in [Unit Off] status



A running wiping cycle cannot be interrupted. The UV system cannot be started during the wiping cycle.

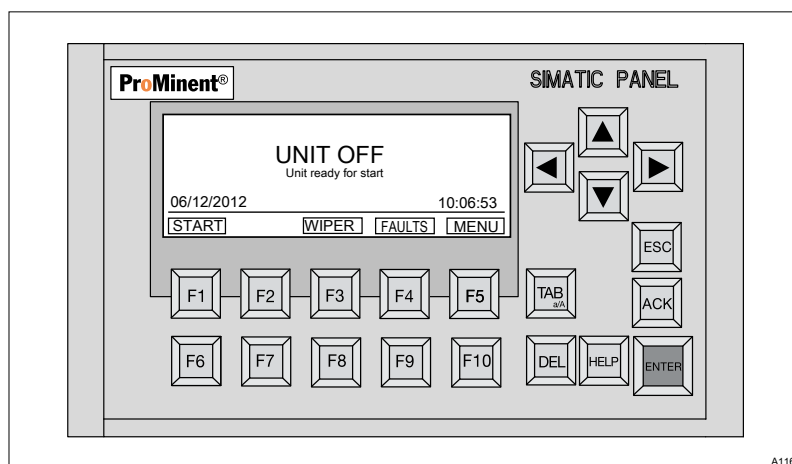

Fig. 11: The display with the UV system switched off

Tab. 3: The following functions can be selected:

Key	Function	Upon selection of the function, the following occur:
[F1]	[START]	Start of the UV system
[F3]	[Wiper]	A wiper cycle is triggered
[F4]	[Fault]	Display of warnings and errors currently present

Key	Function	Upon selection of the function, the following occur:
[F5]	[Menu]	Change to the [Menu] display
[F6 ... F10]	---	---

Description	Function
[ESC]	Jump back
[ACK]	Reset the fault
[DEL]	---
[HELP]	Operating tips
[ENTER]	Entry
Arrow keys	Selection of display fields

6.4.2 Functions of the keys in [PAUSE] status

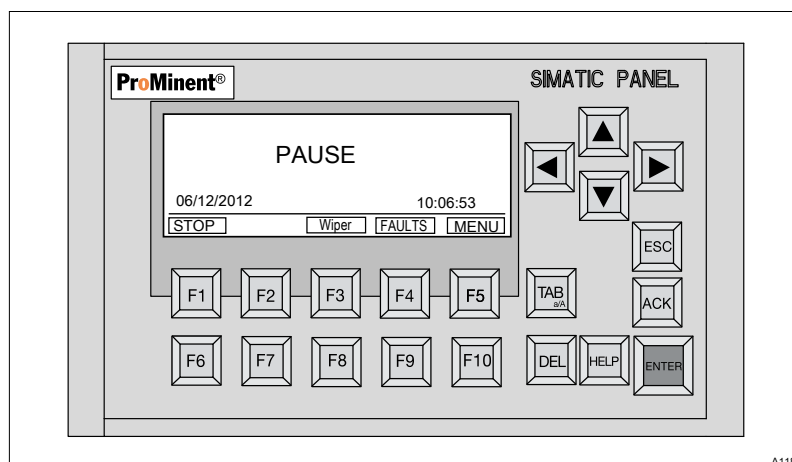

Fig. 12: The UV system display in [PAUSE] status

Tab. 4: The following functions can be selected:

Key	Function	Upon selection of the function and subsequent pressing of Enter, the following occur:
[F1]	[STOP]	The UV system is stopped
[F3]	[Wiper]	A wiper cycle is triggered
[F4]	[Fault]	Display of warnings and errors
[F5]	[Menu]	Change to the [Menu] display
[F2, F6 ... F10]	---	---

Description	Function
[ESC]	---
[ACK]	Reset the fault
[TAB]	Selection of display fields
[DEL]	---
[HELP]	Operating tips
[ENTER]	Entry
Arrow keys	Selection of display fields

6.4.3 Functions of the keys in [COOLING] status

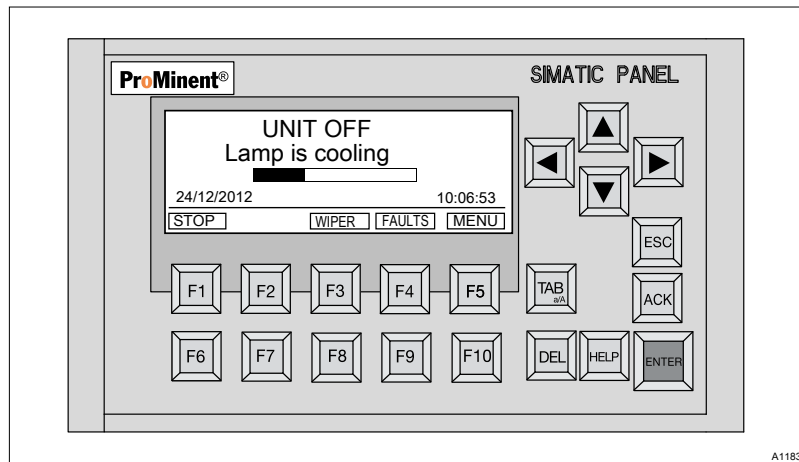

Fig. 13: The UV system display in [COOLING] status

Tab. 5: The following functions can be selected:

Key	Function	Upon selection of the function and subsequent pressing of Enter, the following occur:
[F1]	[STOP]	The UV system is switched off
[F3]	[Wiper]	A wiper cycle is triggered
[F4]	[Fault]	Display of warnings and errors
[F5]	[Menu]	Change to the [Menu] display
[F2, F6 ... F10]	---	---

Description	Function
[ESC]	---
[ACK]	Reset the fault
[TAB]	Selection of display fields and numbers
[DEL]	---
[HELP]	Operating tips
[ENTER]	Entry
Arrow keys	Selection of display fields

6.4.4 Functions of the keys in [Startup] status



When the UV system starts up, the UV lamps are first ignited and then the system waits until the UV lamps have reached their operating temperature and are able to provide their full UV power. If the UV lamps have not ignited after 5 minutes, UV system enters [Fault] status.

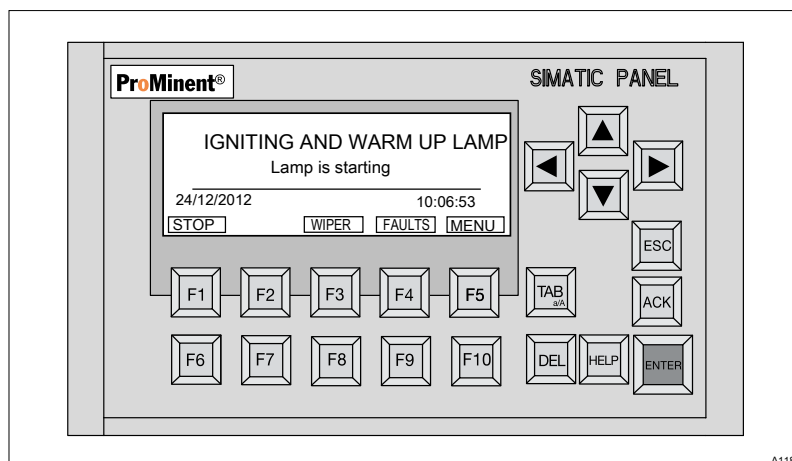

Fig. 14: The UV system display in [Startup] status

Tab. 6: The following functions can be selected:

Key	Function	Upon selection of the function and subsequent pressing of Enter, the following occur:
[F1]	[STOP]	The UV system is switched off
[F3]	[Wiper]	A wiper cycle is triggered
[F4]	[Fault]	Display of warnings and errors
[F5]	[Menu]	Change to the [Menu] display
[F2, F6 ... F10]	---	---

Description	Function
[ESC]	---
[ACK]	Reset the fault
[TAB]	Selection of display fields
[DEL]	---
[HELP]	Operating tips
[ENTER]	Entry
Arrow keys	Selection of display fields

6.4.5 The function of the keys in *[Commissioning rinse]* mode

The message *[Commissioning rinse]* appears in the display and the remaining rinse time is displayed.

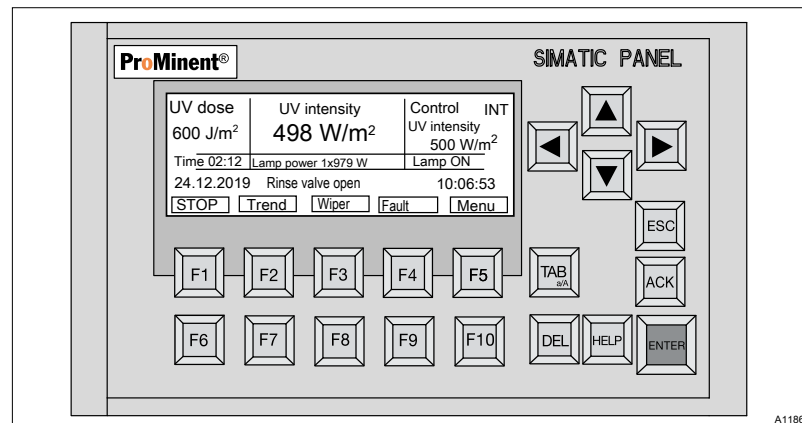

Fig. 15: The UV system display in *[Commissioning rinse]* mode.

Tab. 7: The following functions can be selected:

Key	Function	When the function is selected and Enter is pressed:
[F1]	[STOP]	Switches off the UV system.
[F4]	[Fault]	Warnings and errors are displayed.
[F5]	[Menu]	Switches to the [Menu] display.
[F2, F3, F6 ... F10]	---	---

Designation	Function
[ESC]	---
[ACK]	Reset the fault
[TAB]	Select display fields
[DEL]	---
[HELP]	Operating information
[ENTER]	Entry
Arrow keys	Select display fields

6.4.6 Functions of keys in *[Free rinse]* mode

Free rinsing takes place when operating the UV system if the level has fallen below the minimum radiation intensity (= safety threshold) for instance due to turbidity in the water flow. Should the level fall below the minimum radiation intensity, the shut-off valve (1) closes, see Fig. 3 and the rinse valve (2) opens for the set time. The water flow is diverted to the sewage system. If during the free rinsing time, the minimum radiation intensity is exceeded by $\geq 2\%$, the UV system switches to normal mode again (Warning status). The rinse valve closes and the shut-off valve opens.

A wiping cycle is performed at the start of the *[Free rinse]*. The free rinse time only starts at the end of the wiping cycle. If there is a wiper fault, the wiping cycle is omitted and the free rinse time starts immediately. If during the *[Free rinse]* a further wiping cycle is triggered, then the free rinsing period does not continue during the wiping cycle.

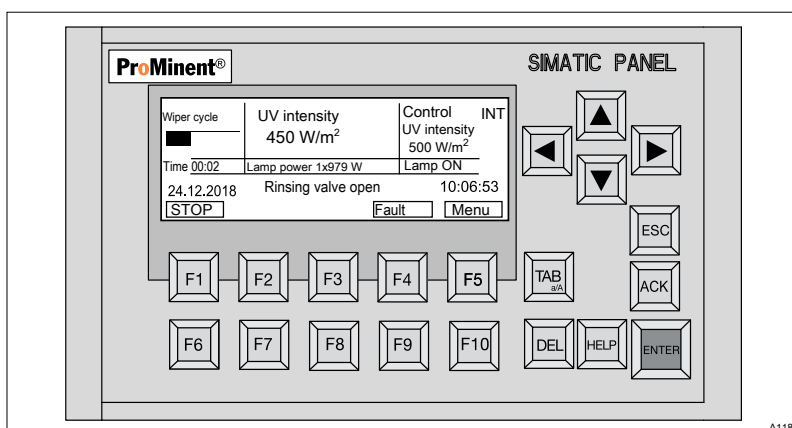

Fig. 16: The UV system is displayed in *[Free rinse]* status until the wiping cycle has been completed.

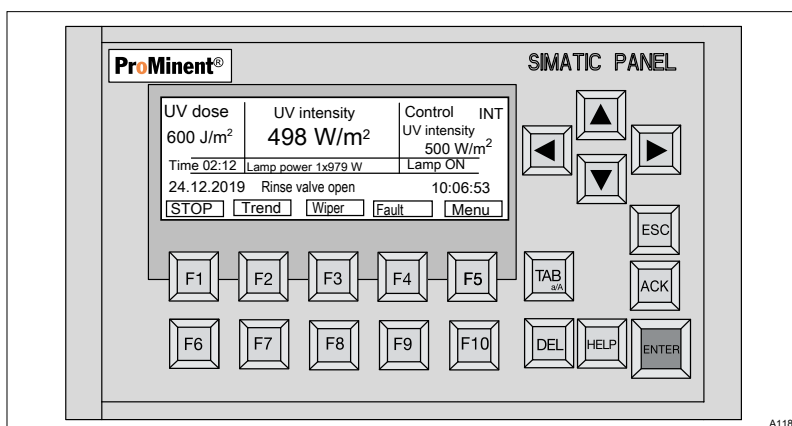

Fig. 17: The UV system display in *[Free rinse]* status. The message *[Rinse valve open]* appears in the display.

Tab. 8: The following functions can be selected:

Key	Function	When the function is selected and Enter is pressed:
[F1]	[STOP]	Switches off the UV system.
[F4]	[Fault]	Warnings and errors are displayed.

Key	Function	When the function is selected and Enter is pressed:
<i>[F5]</i>	<i>[Menu]</i>	Switches to the <i>[Menu]</i> display.
<i>[F2, F3, F5 ... F10]</i>	---	---

Designation	Function
<i>[ESC]</i>	---
<i>[ACK]</i>	Reset the fault.
<i>[TAB]</i>	Select display fields and numbers.
<i>[DEL]</i>	Delete numbers.
<i>[HELP]</i>	Operating information.
<i>[ENTER]</i>	Entry.
Arrow keys	Select display fields and numbers.

6.4.7 The function of the keys in *[Normal operation]* mode

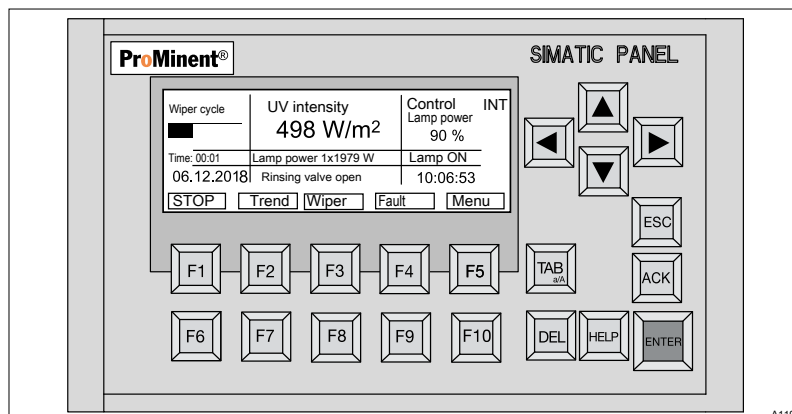

Fig. 18: The UV system is displayed in *[Normal operation]* mode until the wiping cycle has been completed.

The wiper message only appears during a wiping cycle. The *[Wiper]* menu field is not displayed during the wiping process. If there is a wiper fault, the wiper cycle is omitted.

Tab. 9: The following functions can be selected:

Key	Function	When the function is selected and Enter is pressed:
[F1]	[STOP]	Switches off the UV system
[F2]	[TREND]	Display of the development of the lamp power over a period of up to 120 days
[F3]	[Wiper]	Change to the <i>[Wiper]</i> menu
[F4]	[Fault]	Display of warnings and errors
[F5]	[Menu]	Change to the <i>[Menu]</i> display
[F1 ... F10]		Entry of numbers
		The target power of the UV lamp can be changed by highlighting it with the cursor or the <i>[TAB]</i> key.

Description	Function
[ESC]	- - -
[ACK]	Reset the fault
[TAB]	Select display fields and numbers
[DEL]	Delete numbers
[HELP]	Operating information
[ENTER]	Entry
Arrow keys	Select display fields and numbers

6.4.8 The function of the keys in *[Post-burning]* status

- In *[Post-burning]* status, neither the minimum radiation intensity nor the warning threshold is monitored
- A wiping cycle that has been started is ended
- A wiping cycle is displayed in the normal position in the display
- The post-burning time is indicated on the display
- Once the UV lamp has been switched off, the message *[Wait]* appears on the display until the lamp drivers of the UV lamps have signalled *[Off]*

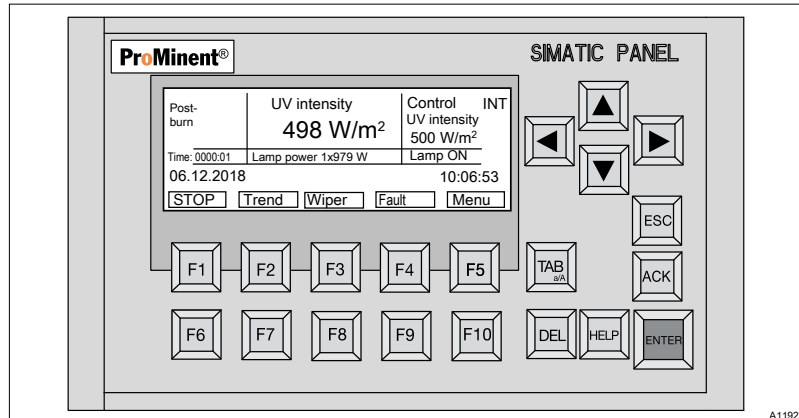

Fig. 19: The UV system display in *[Post-burning]* status

Tab. 10: The following functions can be selected:

Key	Function	When the function is selected and Enter is pressed:
[F1]	[STOP]	The UV system is started after <i>[Post-burning]</i> has ended
[F4]	[Fault]	Display of warnings and errors
[F5]	[Menu]	Change to the <i>[Menu]</i> display
[F2, F3, F6 ... F10]	---	---

Tab. 11: Functions of the keys

Description	Function
[ESC]	---
[ACK]	Reset the fault
[TAB]	Select display fields
[DEL]	---
[HELP]	Operating information
[ENTER]	Entry
Arrow keys	Select display fields

6.4.9 The function of the keys in *[Fault]* status

A fault always leads to the UV system shutting down. A fault can occur because of a defect, by values exceeding or falling below limit values or by an external fault.

Always acknowledge a fault on the UV system and restart the UV system. The UV system restarts here automatically unless the power supply has failed.

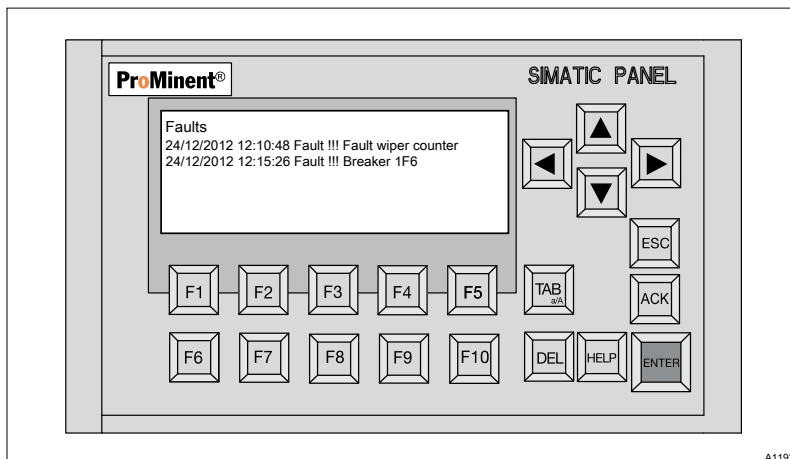

Fig. 20: The UV system display in *[Fault]* status

Tab. 12: Functions of the keys

Description	Function
<i>[ESC]</i>	---
<i>[ACK]</i>	Acknowledge the error
<i>[TAB]</i>	---
<i>[DEL]</i>	---
<i>[HELP]</i>	Operating tips
<i>[ENTER]</i>	---
<i>[F5]</i>	Change to the <i>[Menu]</i> display
<i>[F1 ... F4, F6 ... F10]</i>	---
Arrow keys	Selection of the error messages

6.4.10 Control of the automatic wiper

General information about wiper control

The wiper is driven by an electric motor that has the following inputs and outputs:

- Motor, clockwise rotation
- Motor, anticlockwise rotation
- Pulse output
- Motor, fault

There is also a magnetic proximity switch to monitor the start position of the wiper.

A wiper cycle consists of the forward motion of the wiper element from the start position up to the end of the UV lamp. The end position on the UV lamp is recognised by counting the motor rotations. Then the wiper element returns to the start position. The start position is monitored using the proximity switch.

A wiper cycle can be triggered manually or by the control.

The wiper cycle is superimposed over the various operating statuses. Thus, for example, the UV system continues to be monitored for faults, pause etc. Should the control switch off the UV system, then the wiper cycle ends and the wiper is moved to the start position once the UV system has been switched off. A fault can only be acknowledged or the UV system restarted following the end of the wiper cycle.

To avoid error messages due to shading of the UV sensor by the wiper elements, the status of the warning and safety threshold is frozen at the status prior to the start of the wiper cycle during the wiper cycle. Each time the supply voltage is switched on, the control checks whether the wiper is in the start position. If not, an attempt is made to reach the start position. Only then does the UV system move to *[Off]* status.

If a wiper fault is detected, then an error message is displayed on the display instead of the wiper display and the display is backlit in red. The *'Fault'* output opens. In the event of a fault of the wiper, if the time for the gaps between the wiping cycles is set to 0, the wiper is deactivated and the UV system continues its operation. The UV system is in *'Warning'* status and the display is backlit in yellow. Further wiping cycles are no longer triggered, otherwise the UV system continues running as normal. The fault can only be acknowledged if the UV system is switched off.



Operation without wiper

Continuous operation of the UV system without a wiper is not permitted. The cause of the wiper fault has to be rapidly eliminated to ensure reliable disinfection of the water.

6.5 Menu

6.5.1 The first operating and display level

- **User qualification:** instructed user, see ↗ Chapter 3.2 'User qualification' on page 12

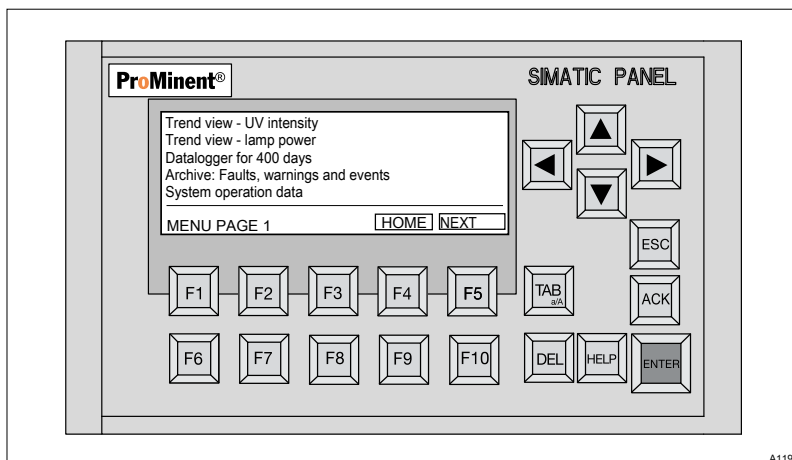

Fig. 21: The first operating and display level

6.5.1.1 Trend view - UV intensity

Up to 192 hours (8 days) can be written. Use the arrow keys to set the display interval between 10 seconds, 1 hour and 1 day.

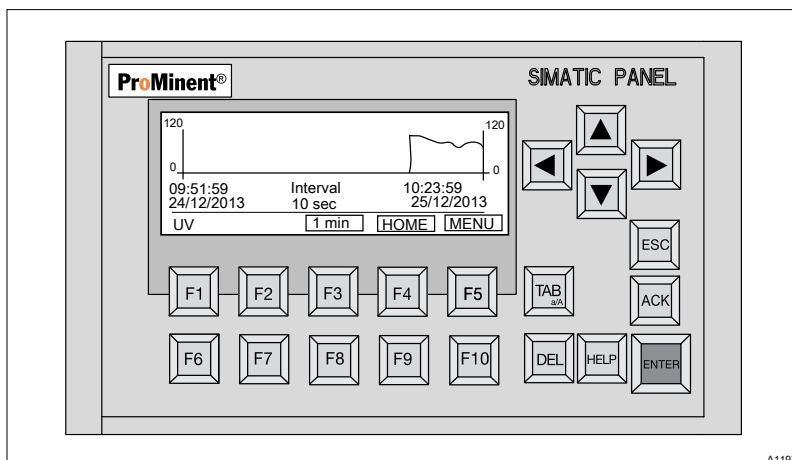

Fig. 22: Trend view - UV sensor

6.5.1.2 Trend view - Lamp power

Up to 192 hours (8 days) can be written. Use the arrow keys to set the display interval between 10 seconds, 1 hour and 1 day. This is displayed for 0 ... 100 %, noting the minimum power. The trend shows the power consumption (watt) of the UV lamp in %. The maximum lamp power is 100%.

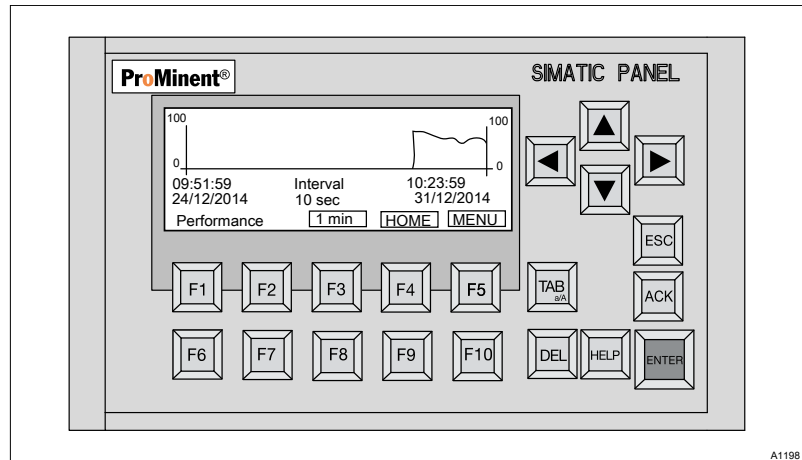

Fig. 23: Trend view - Lamp power

6.5.1.3 [Data logger for 400 days]

One data set is created for every operating day in the [data logger for 400 days]. An operating day is deemed to have occurred if the UV lamp is operated for a minimum of 10 minutes. After these 10 minutes, the current data for the UV sensor signal and the electrical power to the UV lamp is written into the table with the date. These are current operating values and not average values. Depending on when the 10 minutes take place, the data set can be recorded at different times. The last 401 data sets are documented. Thereafter the oldest data sets are automatically overwritten. The data sets are retained even after a power failure. The data is deleted after resetting the system configuration or with new software.

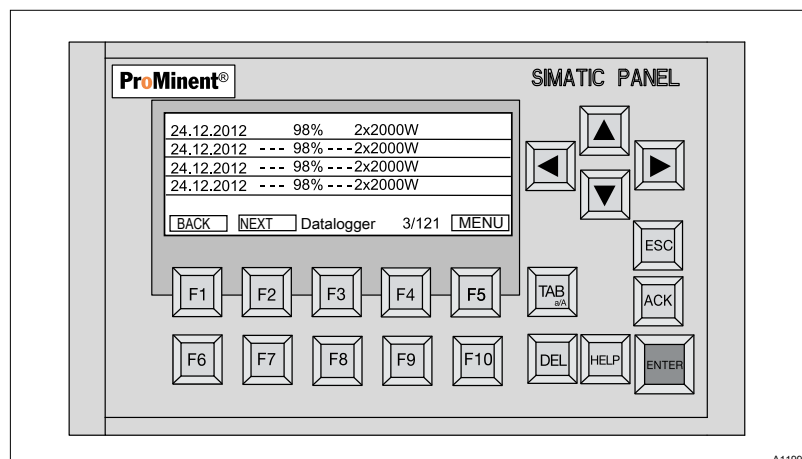

Fig. 24: [Data logger for 400 days]

6.5.1.4 [Archive: Faults, warnings and events]

Events, warnings and alarm messages are saved and displayed.

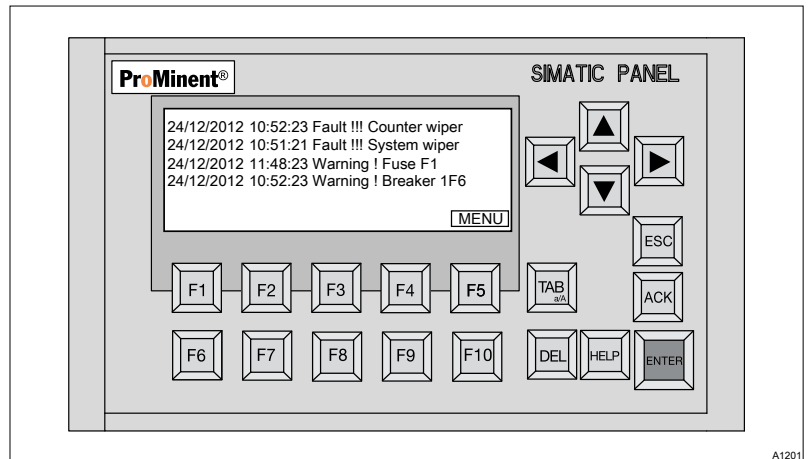

Fig. 25: [Archive: Faults, warnings and events]

6.5.1.5 [Operating Data]

Operating hours and connections are displayed. You can reset the UV lamp' operating hours counter after replacing the UV lamp. This data logger is deleted when the software in the UV system is updated.

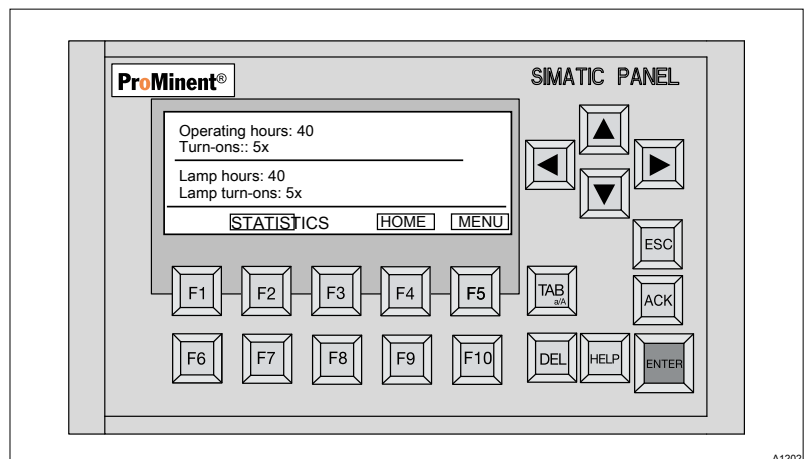

Fig. 26: [Operating data]

6.5.2 The second operating and display level

- **User qualification:** trained user ↪ *Chapter 3.2 'User qualification' on page 12*

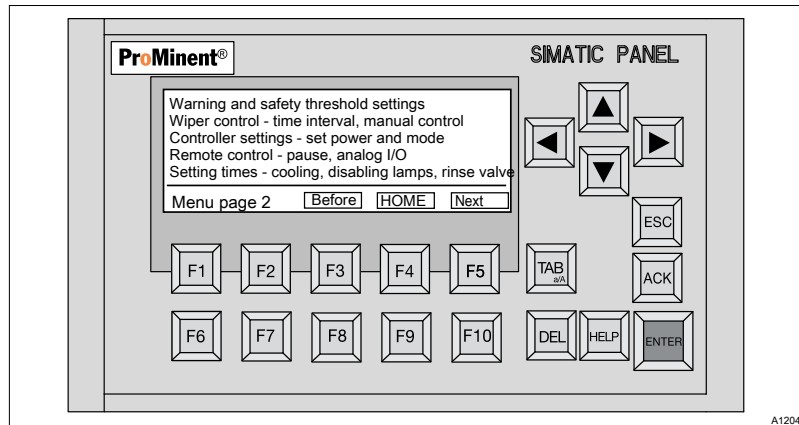

Fig. 27: The second operating and display level

6.5.2.1 Warning and safety threshold settings

You can set the warning and safety threshold in this menu, see also ↪ *Chapter 6.3 'Adjusting the Dulcodes A control' on page 20.*

The setting for the warning and alarm limit depends on the type of control selected:

- The UV sensor signal is monitored in W/m^2 with internal control by specification of the electrical lamp power. Limits are absolute values and remain constant when the setpoints change.
- In the event of control by specification of the UV sensor signal in W/m^2 , any deviation below the setpoint is monitored as a %. The limits move as the setpoint changes. The absolute gap between the setpoint and the limit decreases with smaller setpoints. If the second stage is selected via the digital contact input, then the limits are also monitored with the percentage deviation.

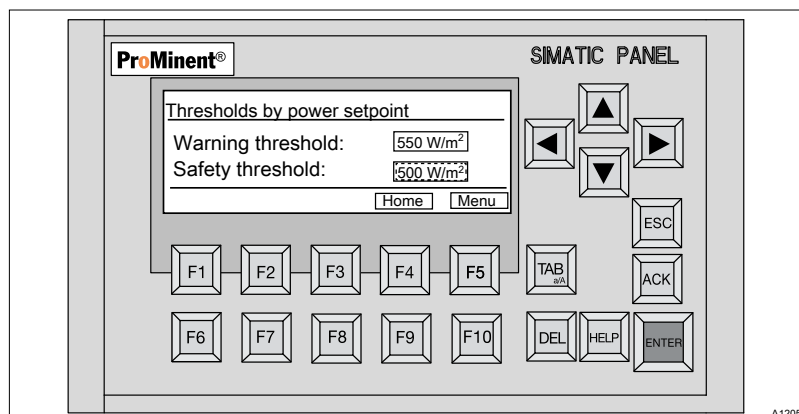

Fig. 28: [Thresholds by power setpoint] internal

The warning threshold can only be set to be greater than the safety threshold.

6.5.2.2 [Wiper control - time interval, manual control]

You can set the wiper interval in this menu.

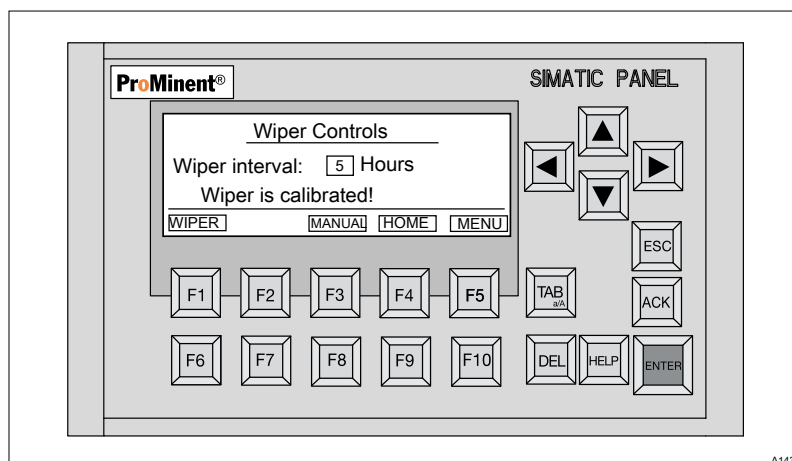

Fig. 29: [Wiper control - time interval, manual control]

1. Use the [TAB] key to select the number of hours
2. Now press [ENTER].
 - ⇒ The message [Function keys are deactivated] now appears; you can now enter the required number of hours using key values 0 ... 9.
3. Enter a single-digit figure for the number of hours of between 0 ... 9 hours
4. Confirm the value by pressing [ENTER]
5. Now press the F5 [MENU] key
 - ⇒ The entered value is saved and the display again shows the selection of the second operating and display level

Auto / Manual

Use [F3] to switch between [AUTO] and [MANUAL]

[MANUAL] sets the position of the wiper, the maximum wiping length and the home position (black circle at home). The travel of the wiping movement is linked to the size of the system and is automatically selected with the configuration. Manual operation is only possible in 'Off' or 'Pause' status, otherwise the wiper could affect the UV sensor signal if the wiper is in a position above the UV lamp or the wiper could be damaged. For this reason, the display is backlit in yellow. The wiper is activated by pressing and holding down the keys for [Forward] and [Back].

6.5.2.3 [Control and setpoint of UV]

You can adjust the UV lamp in this menu. Before adjusting the automatic lamp control, the operating parameters for internal operation (manual mode) or external operation (automatic mode) must be entered in the [Remote control - pause, analog I/O] menu.

Adjusting the control mode

- [F2 = automatic mode]:
 - Control of UV intensity / setpoint specification for UV intensity = UV sensor signal.
- [F1 = manual mode]:
 - Control of lamp power / setpoint specification for lamp power.

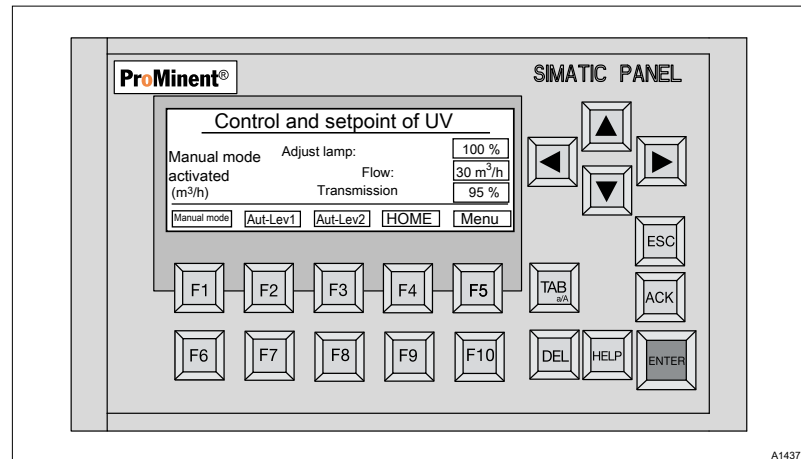

Fig. 30: [Control and setpoint of UV] in control mode: [Lamp power manual mode]

1. Use the [TAB] key to select the value to be adjusted.
2. Now press [ENTER].
 - ⇒ The message [Function keys are deactivated] now appears; you can now enter the desired value using keys 0 ... 9.
3. Enter a value between 0 ... 100 % for the lamp power.
4. Enter the maximum flow.
5. Enter UVT 10 [%/cm] for the transmission.
6. Confirm the value with [ENTER].
7. Now press [F5] [Menu].
 - ⇒ The entered value is saved and the display again shows selection of the second operating and display level.

Two output levels

The UV system has over two freely adjustable output levels. The control has a digital contact input to switch between these two output levels. You can connect a suitable swimming pool controller to measure the combined chlorine to this digital contact input in swimming pool water treatment. In normal operation, the UV system disinfects with with 400 J/m². Should the swimming pool controller measure too high a chloramine value, the UV system is operated at 600 J/m², via the digital contact input, until the chloramine value calls again below the limit value set on the swimming pool controller. This two-stage controller is not used when disinfecting potable water.

External control of lamp output / UV intensity is not possible in power stage 2. In the 'External UV lamp control' control mode, the UV system controls to the set nominal dose of power stage 2.

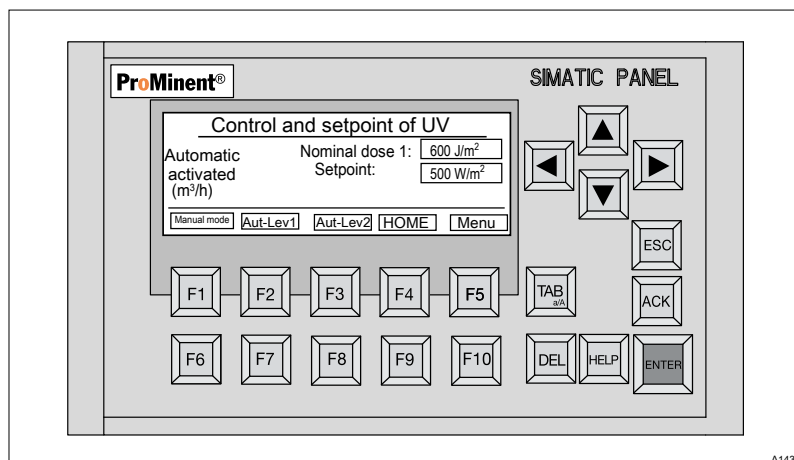

Fig. 31: [Control and setpoint of UV] in control mode: automatic lamp control/power stage 1.

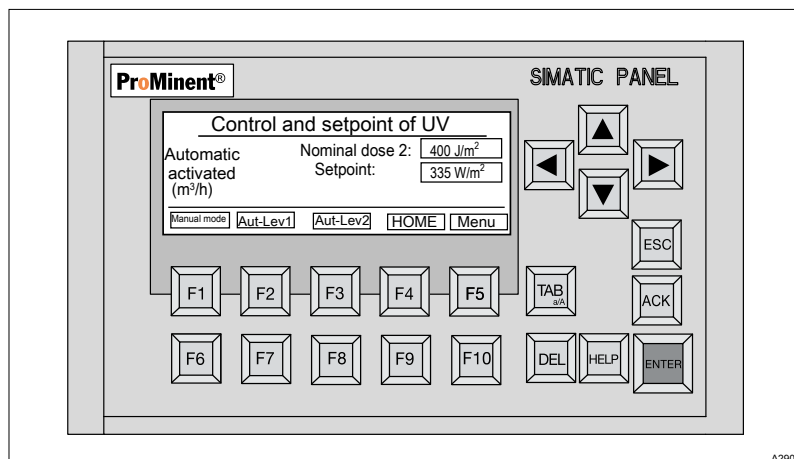

Fig. 32: [Control and setpoint of UV] in control mode: automatic lamp control/power stage 2.

1. Use the [TAB] key to select the value to be adjusted.
2. Now press [ENTER].
 - ⇒ The message [Function keys are deactivated] now appears; you can now enter the desired value using keys 0 ... 9.
3. Enter the desired value.
4. Confirm the value with [ENTER].
5. Now press [F5] [Menu].
 - ⇒ The entered value is saved and the display again shows selection of the second operating and display level.

6.5.2.4 [Remote control - pause, analog I/O]

Selection of the UV lamp control: in the setting [Internal UV lamp control], the control regulates the UV lamp to a constant UV sensor signal. In external UV lamp control via a 4 ... 20 mA input signal, the UV system controls in proportion to the input value using a P control algorithm.

In the [External UV lamp control] control mode, the nominal dose of the [Lamp control automatic mode power stage 1] setting is used. Power stage 2 is deactivated in this control mode.

Pause [YES] or [NO]. Analogue output (0 ... 20 mA or 4 ... 20 mA) for the processed UV sensor signal.

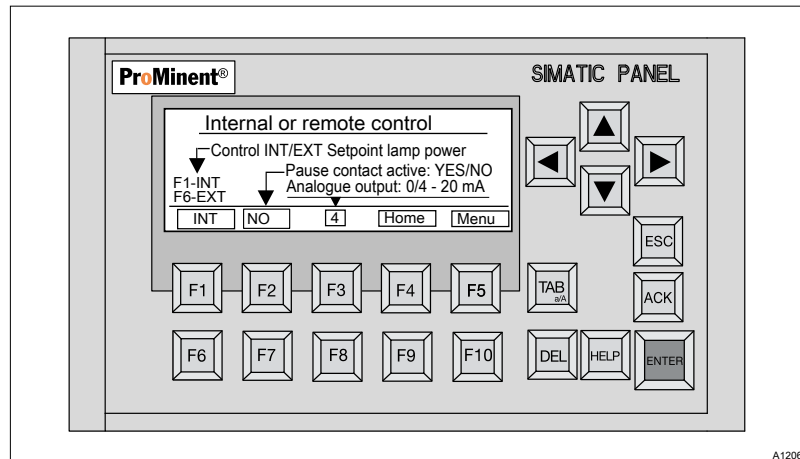

Fig. 33: [Remote control - pause, analog I/O]

UV dose calculation internally [INT]

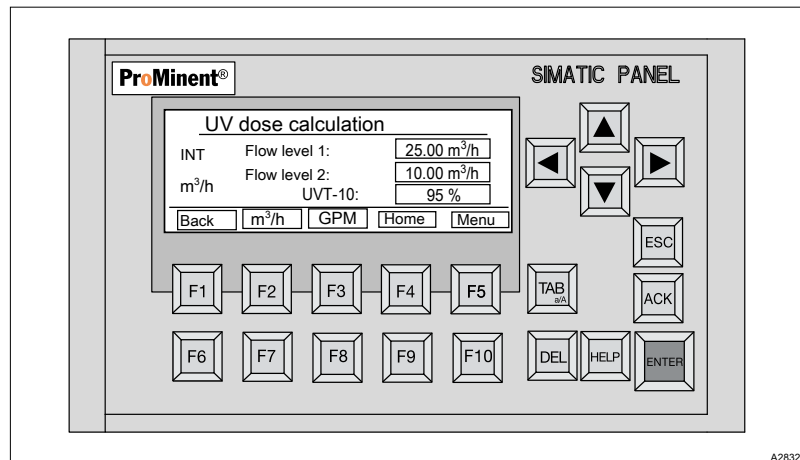
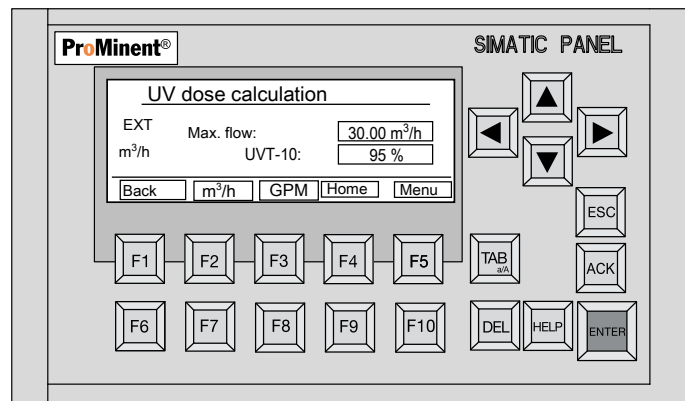

Fig. 34: UV dose calculation internally [INT]

1. Use the [TAB] key to select the value to be adjusted.

You can choose between the [m³/h] and [gpm] display units for the flow

UV dose calculation externally [EXT]



A2833

Fig. 35: UV dose calculation externally [EXT]

With the EXT control mode, the maximum flow corresponds to the 20 mA value of the external input (flow signal).

6.5.2.5 [Setting times - cooling, post-burning, rinse valve]

You can enter the settings for UV lamp post-burn time here. The time for cooling is displayed purely for information purposes. The time for cooling may only be changed after consultation with the manufacturer.

Once the UV lamp has been switched off, the UV lamp has to cool down before an attempt can be made to reignite it. The UV lamp will not ignite without a cool-down. The length of the cooling down period is pre-set and cannot be changed. If the water has to be treated while the shut-off valve is closed and the pump is stopped, then a post-burn time of 0 ... 9.59 minutes can be set. The default setting is 30 seconds.

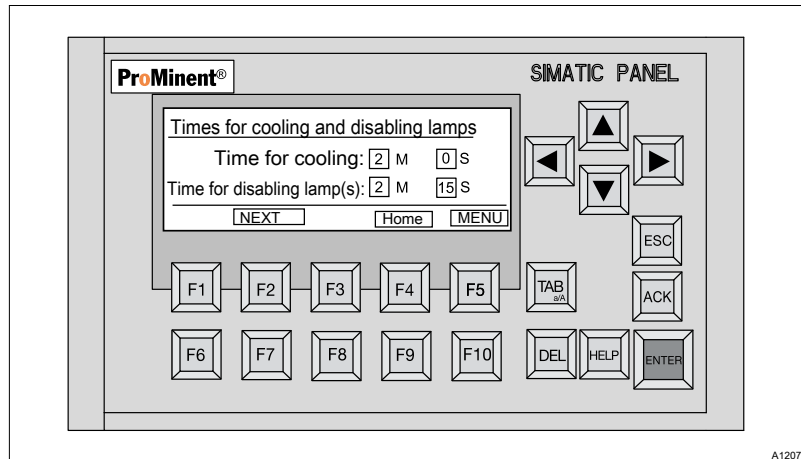

Fig. 36: [Setting times - cooling, post-burning]

You can enter the time settings for the rinse valve here.

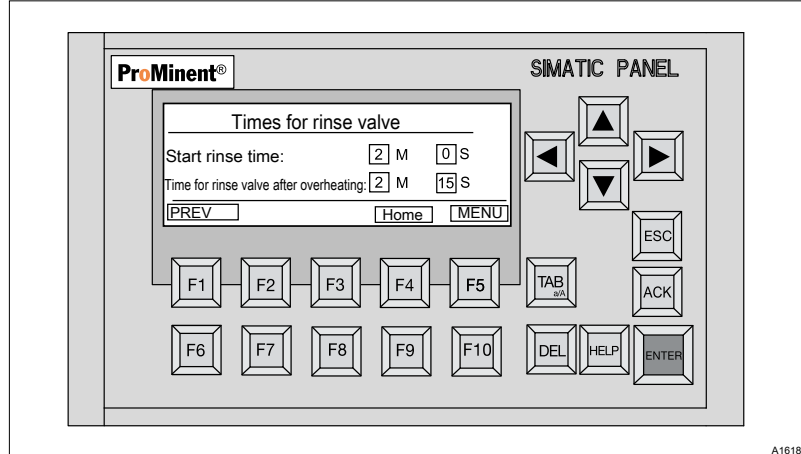

Fig. 37: [Times for rinse valve]

6.5.3 The third operating and display level

- **User qualification:** Service ↗ Chapter 3.2 'User qualification' on page 12



Password

These menus are password-protected, therefore please contact the Service partner for your UV system.

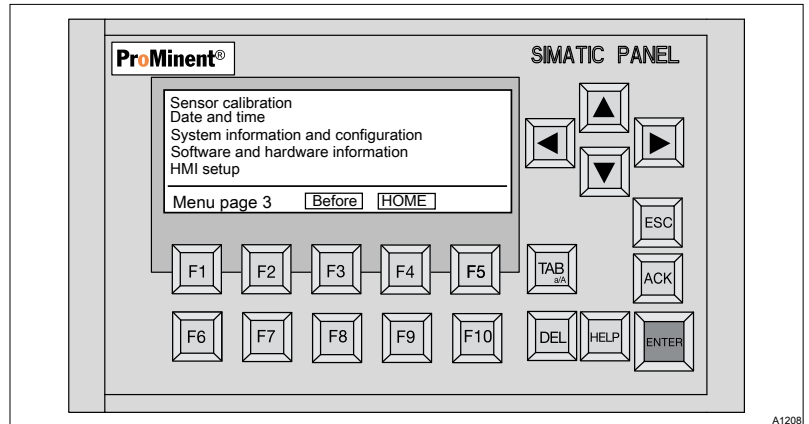

Fig. 38: The third operating and display level

6.5.3.1 [Sensor calibration]

**Sensor calibration**

Only calibrate the sensor with a cleaned UV system and new UV lamps.

The UV sensor is factory-calibrated and does not usually require any further calibration. A sensor calibration has to be undertaken if the displayed sensor signal deviates significantly from the reference radiation intensity stated in the data sheet. The minimum radiation intensity cannot therefore be achieved. You must set the minimum radiation intensity correctly to monitor the UV radiation intensity.

You can calibrate the unit sensor in this menu should the unit sensor deviate from a reference measurement with a calibrated UV sensor.

The UV signal must not change again before the calibration. A changing UV sensor signal indicates that the UV lamp has not yet warmed up sufficiently. Allow the activated UV system to warm up for a short while.



The calibration process can be terminated at any time by pressing [F1], [F2] and [F5]. The UV system then continues working with the values of the last valid calibration and issues an error message under certain circumstances.

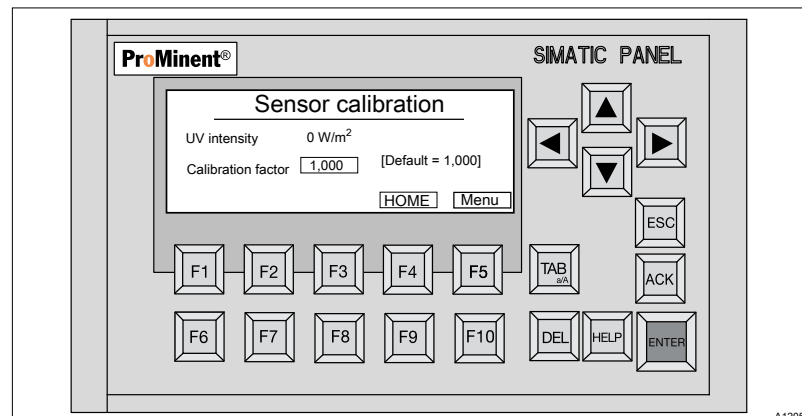

Fig. 39: Calibration of the UV sensor

6.5.3.2 Date and time

You can set the following parameters:

- Month
- Day
- Year
- Hours
- Minutes

Confirm the [Entry] by pressing the [F3] key

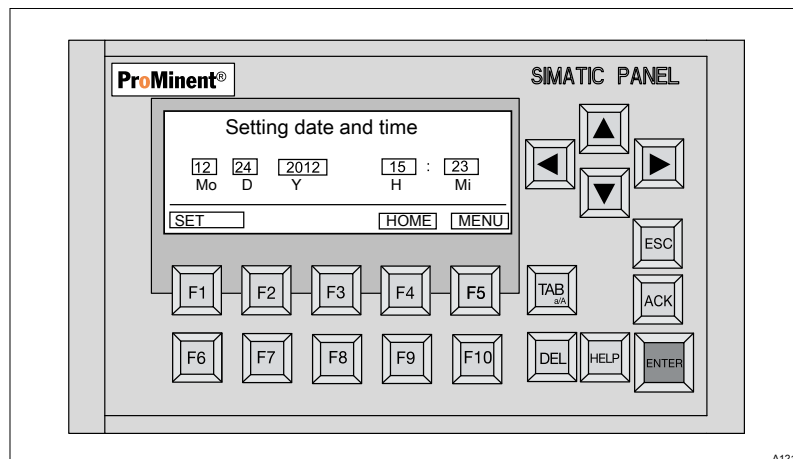

Fig. 40: Setting date and time

6.5.3.3 [System information and configuration]



Password

These menus are password-protected, therefore please contact the Service partner for your UV system.

Pressing Reset resets all operating parameters and settings and the default values are used. Only reset the UV system when it is switched off.

Information on the project is displayed. You can change or display the entries using [F3].

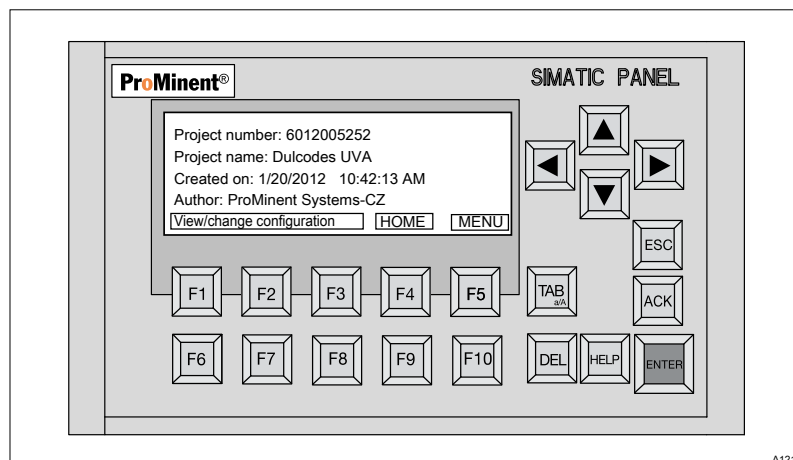

Fig. 41: Displaying and changing the system configuration

You will see this display when **[F3]** has been pressed. The display shows the current configuration of the UV system. The configuration can be reset for a new set-up using **[F3]** **[RESET]**.



NOTICE!

Incorrect settings

Incorrect settings can result in damage to the UV system.

Please note the configuration and read the data sheet for your UV system.

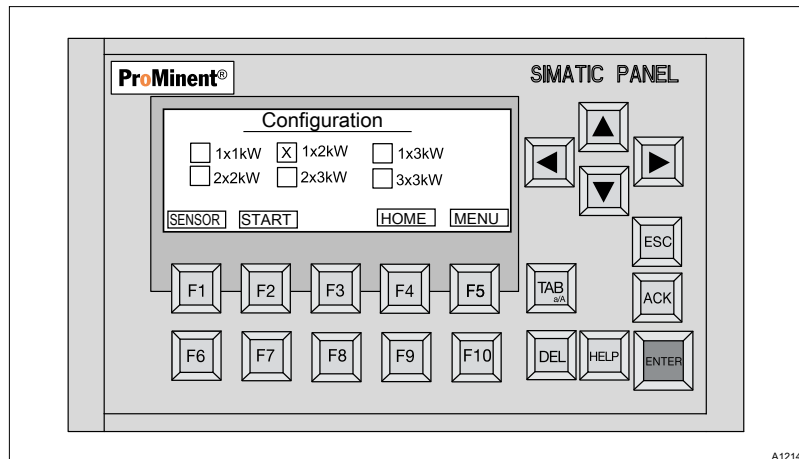

Fig. 42: Changing the system configuration

6.5.3.4 [Software and hardware information]

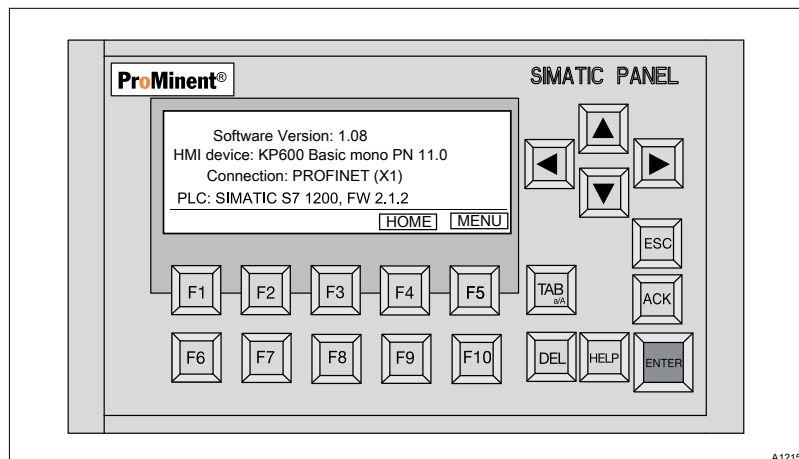

Fig. 43: [Software and hardware information]

6.5.3.5 HMI set-up

You can adjust the following parameters with this display:

- Setting the display contrast
- Setting the language

[Stop Runtime] has no function.

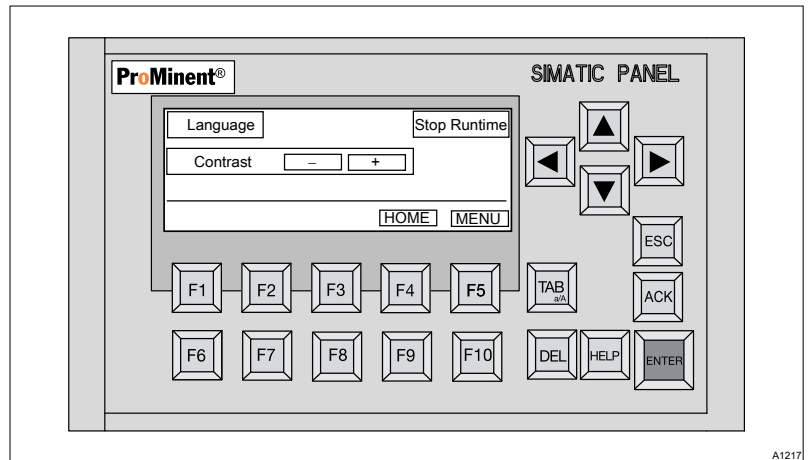

Fig. 44: Setting the language and contrast

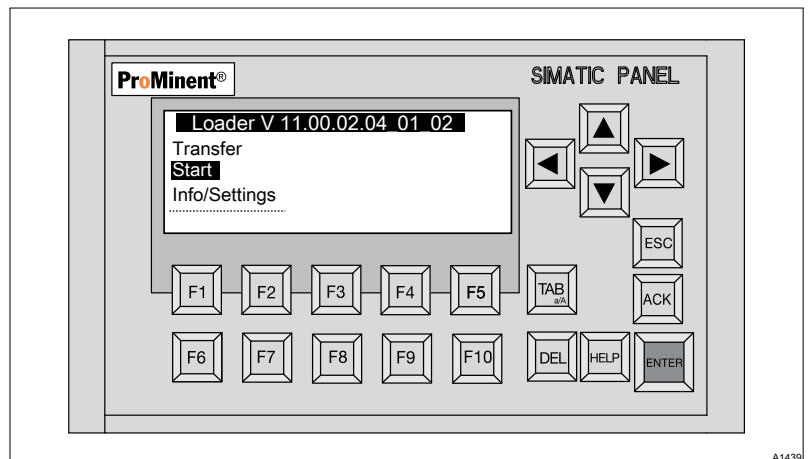

Fig. 45: Display when loading the HMI

7 Assembly and installation

- **User qualification, mechanical installation:** trained and qualified personnel, see ↗ *Chapter 3.2 'User qualification' on page 12*
- **User qualification, electrical installation:** electrical technician, see ↗ *Chapter 3.2 'User qualification' on page 12*



WARNING!

Insufficient disinfection performance

Possible consequence: Illness or disease

Please read the technical data sheet for your system.

Ensure that:

- The maximum permissible water flow rate is not exceeded and
- The UV transmission does not fall below the minimum permissible level
 - otherwise, adequate treatment of the water cannot be guaranteed.



CAUTION!

Unauthorised operating parameters

Possible consequence: Material damage.

Ensure that:

- The installation place is dry and frost-free
- There is guaranteed protection for the UV system from chemicals, dyes and vapours
- The ambient temperature and the radiation temperature in the direct vicinity of the system do not exceed 40 °C
- The maximum permissible operating pressure is not exceeded and
- There are no solid particles and no turbidity in the water to be treated
 - If necessary, fit a suitable filter upstream of the UV system.



NOTICE!

Switching on and off

Possibility of increased wear to the UV lamp

Operate the UV system in such a way that you avoid frequently switching the lamp on and off.

7.1 Installation details

Vertical installation



Fully filled with water

Ensure that the UV system is fully filled with water and water is flowing through it when operating with the UV lamp switched on.

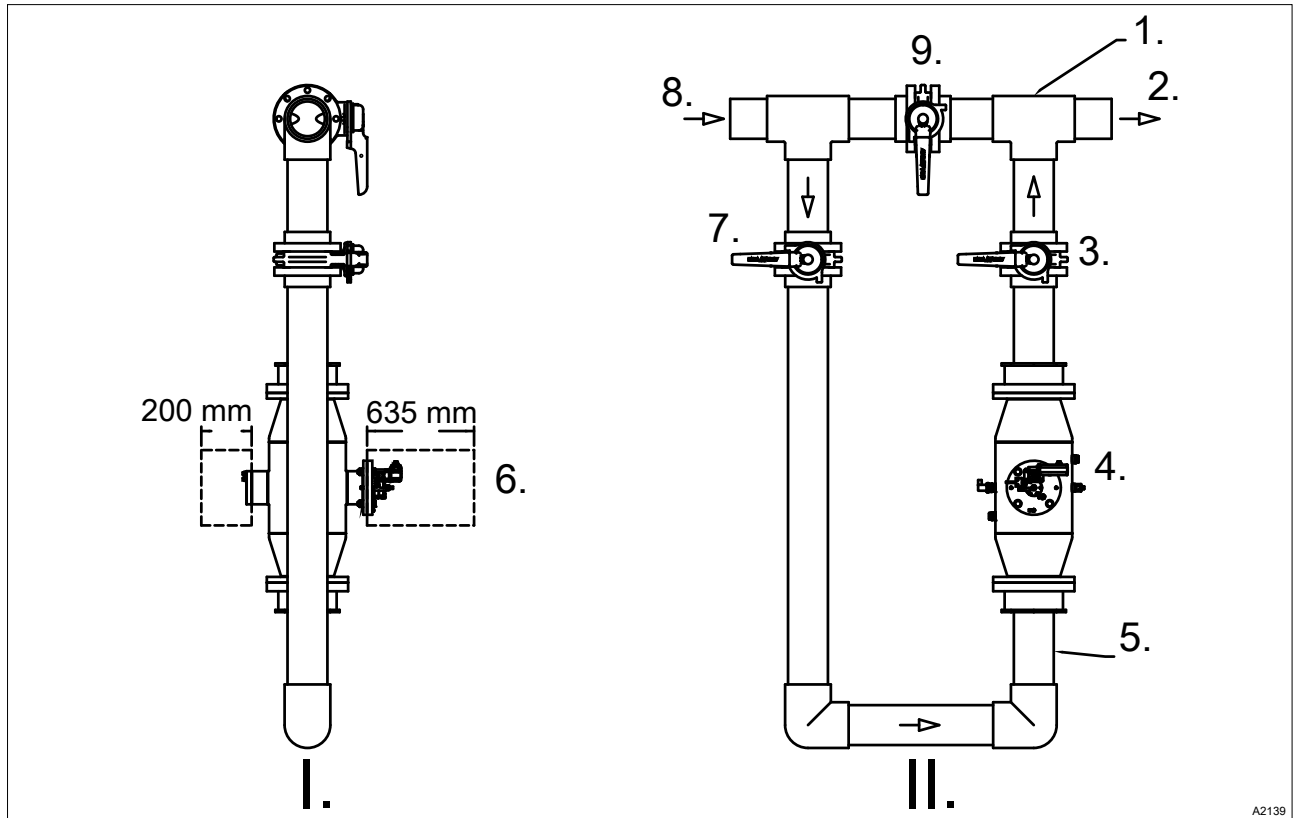

Fig. 46: Vertical installation of the UV system

- | | |
|---|---|
| <ul style="list-style-type: none"> I. Side view II. Front view 1. Bleed valve, provided on site 2. Flow of water to pool 3. Shut-off valve, open in normal operation 4. UV System | <ul style="list-style-type: none"> 5. UV feed and drain pipe has to be 3 ... 5 times the diameter of the pipe 6. Service area, keep free of obstacles 7. Shut-off valve, open in normal operation 8. Flow of water from filter 9. Shut-off valve, closed in normal operation |
|---|---|

Horizontal installation

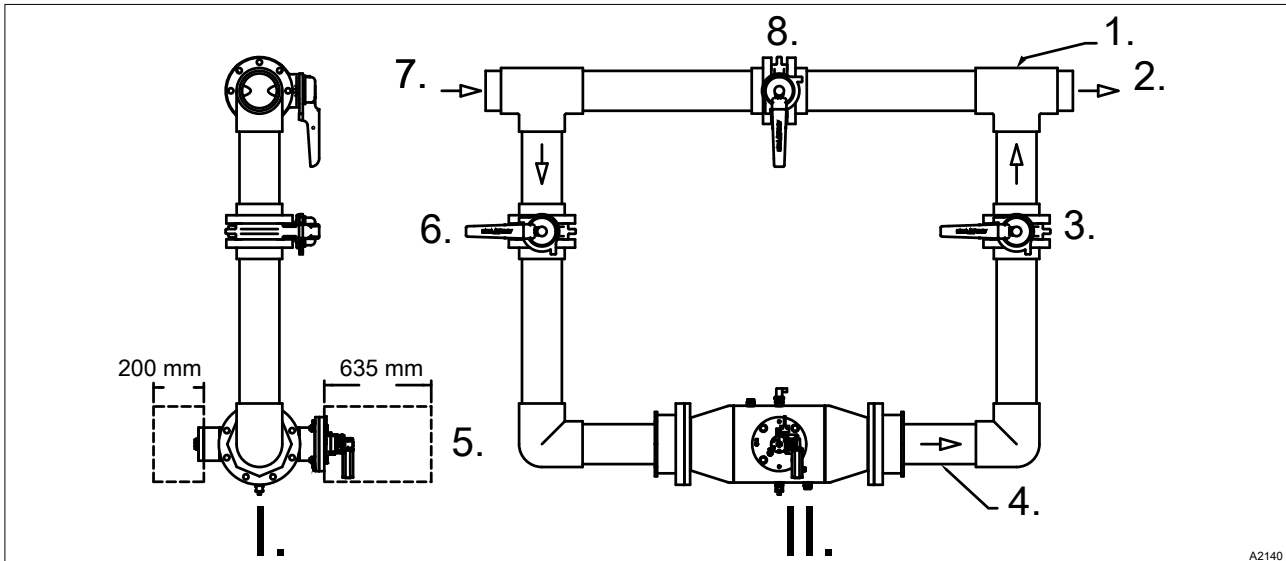

Fig. 47: Horizontal installation of the UV system

- | | |
|--|---|
| I. Side view | 5. Service area, keep free of obstacles |
| II. Front view | 6. Shut-off valve, open in normal operation |
| 1. Bleed valve, provided on site | 7. Flow of water from filter |
| 2. Flow of water to pool | 8. Shut-off valve, closed in normal operation |
| 3. Shut-off valve, open in normal operation | |
| 4. UV feed and drain pipe has to be 3 ... 5 times the diameter of the pipe | |

Electrical wiring diagram

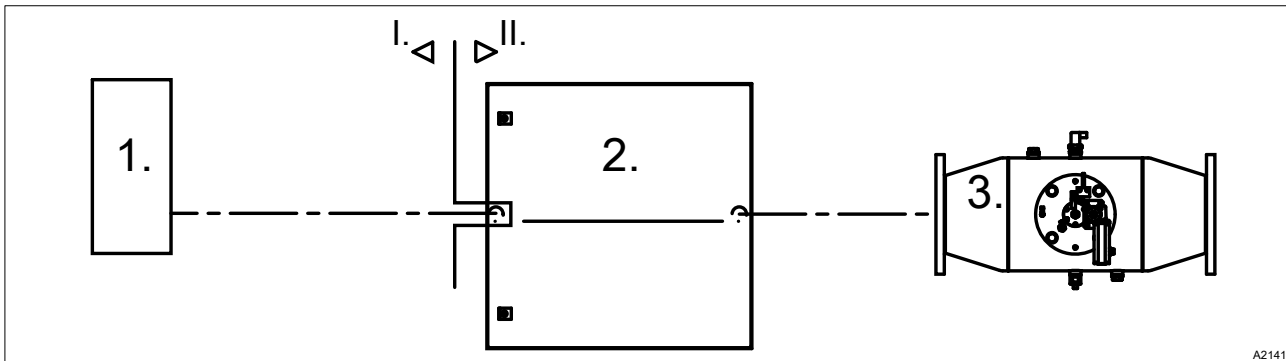

Fig. 48: Electrical wiring diagram

- | |
|--|
| I. Provided on site |
| II. Scope of delivery of the UV system |
| 1. Power supply cable with appropriate fuse, as per wiring diagram |
| 2. Control cabinet; max. 10 metres from UV radiation chamber |
| 3. UV radiation chamber |

7.2 Radiation chamber

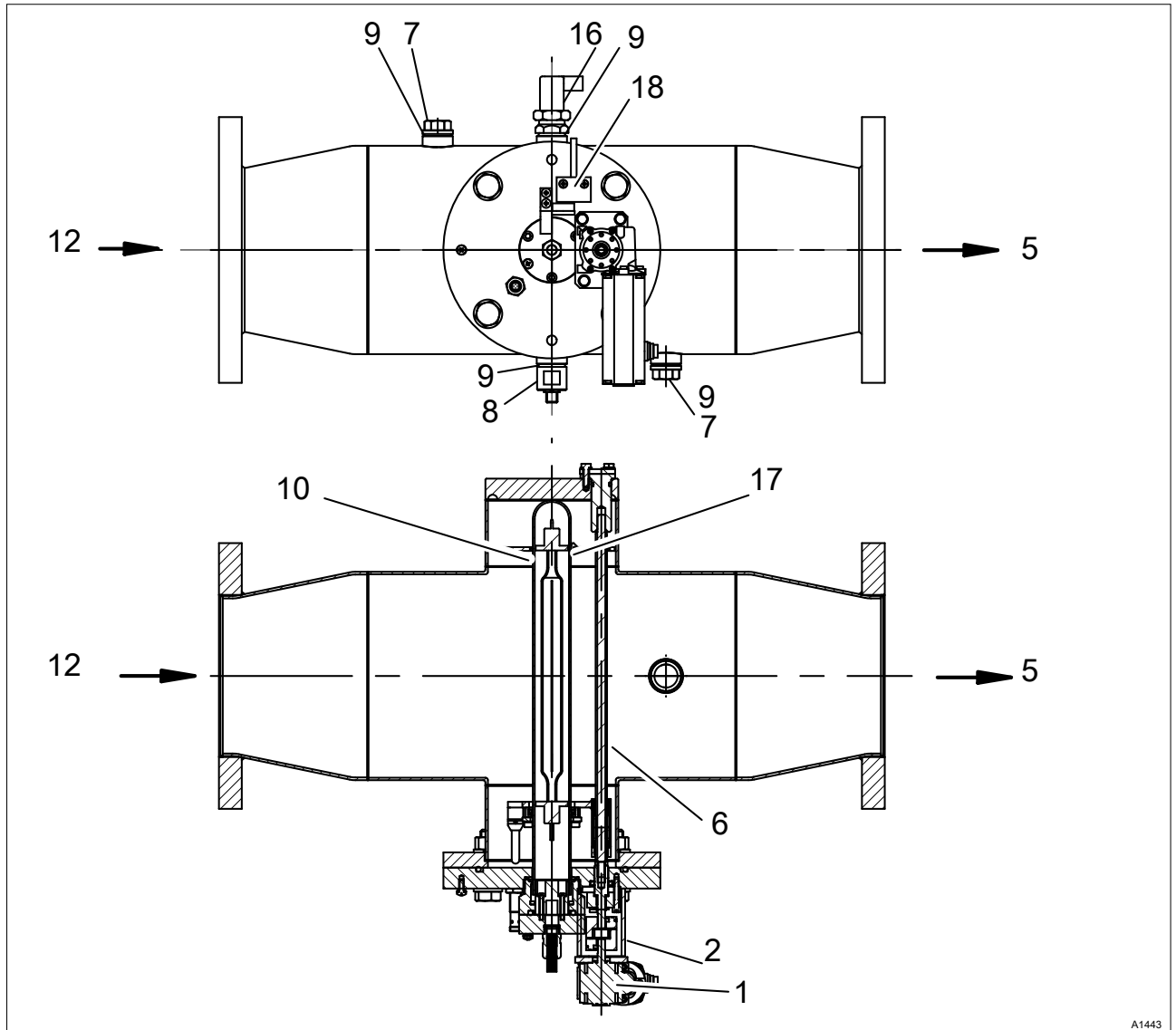

Fig. 49: Construction of the radiation chamber

- | | |
|--|---|
| 1. Motor | 9. O-ring |
| 2. Protective cover | 10. Lamp protection tube |
| 5. Outlet | 12. Inlet |
| 6. Wiper rod | 16. Temperature switch |
| 7. Air vent/Drain/Flushing connection with O-ring
(depending on the fitting position) | 17. Support plate for UV lamp protection tube |
| 8. UV sensor | 18. Safety switch |

7.2.1 Assembly

Location



Maintenance work

Leave adequate room for maintenance work

The clearance required can be found in the enclosed dimensions sheet.

Fix the radiation chamber in place with appropriate fixing material (pipe clamp, frame). The installation location can in principle be chosen at random and, if required, can be adapted to conditions on site.

7.2.2 Attach the warning label



NOTICE!

The supplied self-adhesive warning label should be attached to the reactor so that it is clearly visible.

7.2.3 Hydraulic Connections



CAUTION!

Installation regulations

Possibility of incorrect assembly

Make the hydraulic connections on the radiation chamber in compliance with the applicable general guidelines and local installation regulations.



CAUTION!

Damage to lamp and wiper element

Possibility of damage to lamp and wiper element.

The UV-system may only be operated when the radiation chamber is fully filled with water. With an empty or only partially filled radiation chamber there is a risk of damaging the lamp, radiation chamber and wiper element.

It must therefore be ensured that the radiation chamber cannot run empty when the pump is switched off.



NOTICE!

- Provide valves upstream and downstream of the radiation chamber to shut off the radiation chamber for maintenance work
- It is also recommended in case of radiation chambers regularly cleaned by filling with a cleaning solution that the water drain connector and the air vent plug be replaced by appropriate valves
- With larger radiation chambers, it is recommended that they are filled through the water drain opening using an appropriate acid-resistant pump
- If the radiation chamber is filled with a pump, it is also useful to circulate the cleaning solution through the air vent opening. This shortens the cleaning time and achieves a better result

7.3 Control cabinet and control

7.3.1 Assembly



NOTICE!

The connecting cable for the UV lamp and the UV sensor cable may not be lengthened!

The control cabinet or the mounting panel with controller and power supply unit should be fitted to the wall or a suitable frame in such a way that the UV lamp and the UV sensor can be connected to the cables provided.

7.3.2 Electrical connections



WARNING!

Electrical connections

Possible consequence: Fatal or very serious injuries.

- Please observe all generally applicable guidelines and local installation regulations.
- Only carry out installation work on the UV system if it is disconnected from the mains power supply.
- Connect a protective earth conductor to the reactor and to the reactor cover. Ensure a continuous power supply by means of a suitable fault current protection.
- Only an authorised electrical technician may open the control cabinet!
- Do not lengthen the connecting cable for the UV lamp or the UV sensor cable.
- The electrical installation must be carried out by an authorised electrical technician using the documents supplied (wiring diagram).

7.3.3 Fitting the temperature sensor



WARNING!

Overheating of the radiation chamber

Possible consequences: Serious personal injury and material damage due to overheating.

The radiation chamber may overheat if the temperature sensor is not fitted correctly.

Screw the temperature sensor, which monitors the water temperature, into the straight union provided for this on the radiation chamber.

1. Carefully push the O-ring over the thread of the temperature sensor
2. Screw the temperature sensor into the straight union until "hand-tight"
3. Attach the connecting cable and fix in place

7.4 Fitting the UV lamp protection tube

7.4.1 Fitting the UV lamp protection tube with automatic wiper

1. ➤ Loosen the lamp protection tube bracket with a face spanner and remove it (place on the holes - not on the threads!)
2. ➤ Carefully push the UV lamp protection tube into the radiation chamber until it reaches its stop position
3. ➤ Push a new O-ring onto the end of the UV lamp protection tube

4. ➤



CAUTION!

- Check the UV lamp protection tube for damage before fitting
- A damaged UV lamp protection tube may not be refitted
- Ensure that the UV lamp protection tube is sitting correctly

Ensure that the UV lamp protection tube is sitting correctly. The UV lamp protection tube may not project out more than 13 mm and may not be offset at an angle.

5. ➤ Screw the UV lamp protection tube bracket into the chamber cover until hand-tight.

6. ➤



Threaded holes

Place the screwdriver on the holes - not on the threads. The threads could be damaged irreparably.

Then tighten the UV lamp protection tube bracket using the screwdriver provided, tightening angle $90^\circ \pm 5^\circ$

⇒



Leak test

Following this, check the leak-tightness of the UV system.

7.5 Assembly and connection of the UV lamp



WARNING!

Consequence: Serious injuries.

UV-C radiation is harmful to the eyes and skin

- Only start up the UV lamp  when it is properly installed
- Install the UV lamp into the UV system in accordance with the regulations prior to commissioning



WARNING!

Live parts!

Possible consequence: Fatal or very serious injuries

- Measure: Disconnect the device from the power supply before opening it
- Disconnect damaged and defective devices or devices that have been tampered with from the mains power supply
- Do not modify the fitted UV lamp connection cable without authorisation
- Do not modify the gap between the plug and the UV lamp cover
 - Otherwise, it is not possible to guarantee that the UV lamp lies against the closed end of the UV lamp protection tube



CAUTION!

Fingerprints on the UV lamp

Possible consequence: Premature failure of the UV lamp

- Only touch the glass of the UV lamp when wearing cotton gloves
- Fingerprints or impurities burn into the glass and can result in premature failure
- For this reason always clean the lamp thoroughly with a cloth moistened with alcohol before installing it
- Then wipe the UV lamp with a soft, dry cloth
- Also thoroughly clean the glass of the UV lamp return cable

1. ➤ Check whether the O-ring on the lamp protection tube bracket is lying in the groove provided - the sealing surfaces of the O-ring should be completely smooth and clean!
2. ➤ Insert the O-rings provided into the groove on the lamp protection tube bracket
3. ➤ Take the UV lamp out of its protective packaging
4. ➤ Wipe the UV lamp with the cleaning cloth provided
5. ➤ Wipe the UV lamp again with a soft cloth
6. ➤ Insert the UV lamp into the UV lamp protection tube and allow it to project out approx. 100 mm



Position of the lamp return cable.

Check that the lamp return cable is not lying between the UV lamp and the UV sensor. The shadow of the lamp return cable could otherwise distort the measurement of the UV intensity.



Contact problems

Tighten all 4 screws to avoid contact problems.

7. ➤ Fix the UV lamp to the cable clamp with the aid of a slotted head screw driver.
8. ➤ Insert the UV lamp fully into the UV lamp protection tube
9. ➤ Place the UV lamp cover onto the UV lamp protection tube bracket and, using the fixing bolts provided, screw in and tighten using the Allen key supplied
10. ➤ Re-fit the safety switch

7.6 Assembly and installation of the wiper motor

1. ➤ Push the enclosed protective cover (14) over the wiper rod

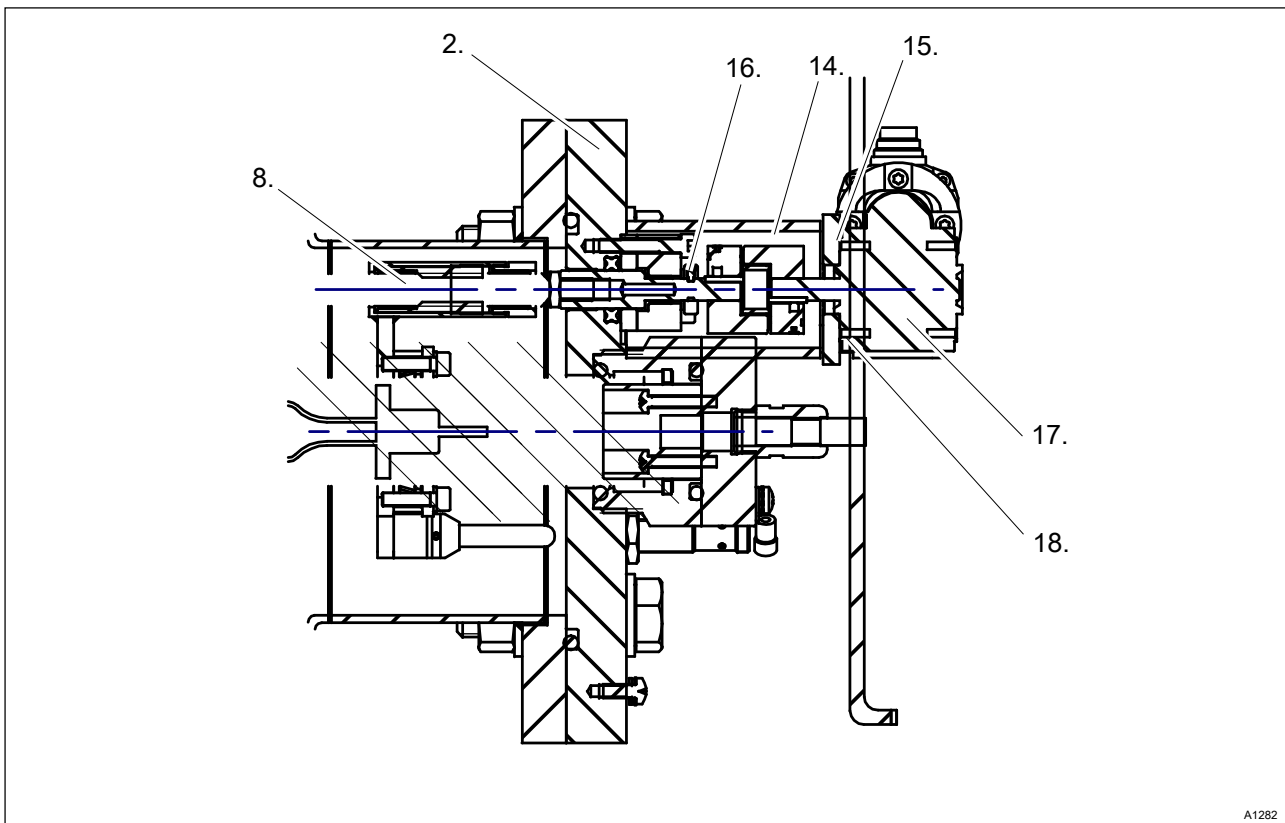

2. ➤ Screw the wiper motor (17) to the adapter plate (15) using the fixing set (18)

8 Commissioning

- **User qualification, commissioning:** trained user ↪ Chapter 3.2 'User qualification' on page 12



Avoid frequent switching operations

Avoid short switching intervals and switching operations. Frequent switching operations can have a negative effect on the service life of the UV lamp.

8.1 Check the control system programming



WARNING!

Insufficient water treatment

The UV transmission of the water must be known before commissioning the UV system.

Please read the technical data sheet for your UV system

Ensure that:

- the maximum permissible water flow rate is not exceeded and
- the UV transmission does not fall below the permissible level,
 - as otherwise adequate treatment of the water cannot be guaranteed because the radiation dose is too low.



NOTICE!

Warning threshold

Failure to set the warning thresholds in accordance with the data sheet will lead to warning alerts being given prematurely or late.



Minimum irradiation intensity

It is especially important to check whether the minimum radiation intensity is set in accordance with the information in the accompanying data sheet. If the minimum radiation intensity is undershot on a regular basis or is permanently undershot, then either the max. flow should be reduced or a water pretreatment process must be installed upstream in order to improve the water transmission value of the UV system.

8.2 Leak testing and ventilation of the reactor

1. ▶ Open the bleed valve on the reactor.
2. ▶ Slowly open the shut-off valve upstream of the reactor.
3. ▶ Fill the reactor until water emerges from the bleed valve.
4. ▶ Close the bleed valve.
5. ▶ Check the reactor for leaks.
6. ▶ Open the shut-off valve downstream of the reactor (only necessary with a manual shut-off valve).

8.3 Switching on the UV system



CAUTION!

Only switch on the UV system after the radiation chamber has been filled with water.

- ▶ Switch on the main switch
 - ⇒ The UV system is now ready for operation.

9 Maintenance

- **User qualification:** trained user ↗ Chapter 3.2 'User qualification' on page 12

**WARNING!****UV-C radiation**

Possible consequence: severe injuries.

UV-C radiation is harmful to the eyes and skin.

- Only operate the UV lamp  when it is fully installed.
- Prior to commissioning, install the UV lamp in the UV system in accordance with the regulations.

**WARNING!****Live parts!**

Possible consequence: fatal or very serious injuries.

- Measure: Disconnect the unit from the power supply before opening it.
- Disconnect damaged and faulty units or units that have been tampered with from the power supply.

**CAUTION!****General precautionary measures**

Ensure that the radiation chamber is at atmospheric pressure before commencing any maintenance work.

Dirty filter mats on the fan and air outlet filter can lead to the control cabinet overheating and becoming irreparably damaged.

**NOTICE!****Maximum permissible service life**

Replace the UV lamps at the latest after their maximum permissible service life. Otherwise, the operating safety of the UV system can no longer be guaranteed.

The maximum permissible service life is 8,000 operating hours, unless otherwise stated on the enclosed data sheet.



Safety switch for the UV lamp cover

The UV lamp cover is protected with a safety switch. The safety switch has a reed switch and comprises two components. The safety switch ensures that the UV lamp only generates UV radiation in its fitted state. If the safety switch is removed, then the UV lamp switches off. If the safety switch is not fitted and thus remains closed, e.g. after installation and maintenance work, then the UV lamp cannot be started.

Maintenance of the UV system is limited to cleaning the UV sensor window and replacing the UV lamps at the end of their maximum permissible service life. In systems with wipers, replace the wiper element and the O-ring of the clamping screw as well.

In systems that have a fan in the control cabinet, regularly replace the filter mats of the fan and air outlet filter on the control cabinet (normally once per year). Keep an operating log as a record; a form is included in the Appendix.

9.1 Maintaining and caring for the KP 300

Introduction

The operating device is designed for low-maintenance operation. You should keep the film keyboard clean.

Requirement

For cleaning use a moist cleaning cloth with cleaning agent. As a cleaning agent use only washing-up liquid or foaming screen cleaning agent.



NOTICE!

Unintended reaction

When cleaning the keyboard film, contact with the keys may trigger an unintended reaction in the control. Switch the operating device off prior to cleaning to avoid unintended reactions.



Damage due to impermissible cleaning agents

When cleaning using compressed air, steam cleaners, aggressive solvents or abrasive agents, the operating device may be damaged. Do not clean the operating device using compressed air or steam cleaners. Do not use any aggressive solvent or abrasive agents.

Procedure

Proceed as follows:

1. ➔



Do not spray the operating device directly.

Switch the operating device off.

2. ➔

Spray cleaning agent on to the cleaning cloth.

3. ➔

Clean the operating device. Wipe by cleaning the display from the screen edge inwards.

9.2 Cleaning

9.2.1 Cleaning the UV lamp protection tube



CAUTION!

Unsuitable cleaning agent

Possible personal injury / material damage to the UV systems

- Do not use corrosive acids or acids that could cause stress cracks, such as hydrochloric acid
- Read the safety data sheet for the cleaning agent selected!
- Wear protective clothing when cleaning (protective eyewear, protective gloves ...)
- Ensure that no cleaning solution penetrates the lamp protection tube
- Ensure, when cleaning UV systems that no cleaning solution enters the pipework



NOTICE!

Cleaning time

Clean the tube at the very latest when the UV sensor signal falls below the warning threshold, without this being based on other causes, such as ageing of the UV lamp or significant worsening of the UV transmission.



NOTICE!

Disposal of cleaning agent

Possible environmental hazard.

Dispose of the waste cleaning solution in accordance with the pertinent guidelines and regulations.

Deposits of, for example iron, manganese or limescale, can form on the UV lamp protection tubes during operation. As these deposits absorb UV radiation, they should be removed at regular intervals.

An annual clean of the UV lamp protection tubes when replacing the UV lamp suffices for many UV systems. Clean more frequently when operating with types of water that have a tendency to become dirty. The UV lamp protection tubes can be cleaned manually when dismantled or can be cleaned by filling the radiation chamber with a cleaning solution. Acids, such as diluted phosphoric acid, acetic acid or diluted nitric acid, are particularly suitable for cleaning.



Manual cleaning, cleaning agents

In spite of cleaning with a wiper, we recommend manual cleaning using cleaning solution, if you remove the UV lamp protection tube within the scope of UV lamp replacement.

In UV systems with automatic wipers, cleaning of the lamp protection tube while fitted is carried out dependent on the set wiper interval (presetting 2 h).

9.2.2 Cleaning after dismantling the UV lamp protection tube



WARNING! **UV-C radiation**

Possible consequence: severe injuries.

UV-C radiation is harmful to the eyes and skin.

- Only start up the UV lamp  when it is properly installed.
- Prior to commissioning, install the UV lamp into the UV system in accordance with the regulations.



WARNING! **Live parts!**

Possible consequence: fatal or very serious injuries.

- Measure: disconnect the unit from the power supply before opening it.
- Disconnect damaged and faulty units or units that have been tampered with safely and as quickly as possible from the mains power supply.



CAUTION! **Fingerprints on the UV lamp**

Possible consequence: premature failure of the UV lamp.

- Only touch the glass of the UV lamp when wearing cotton gloves.
- Fingerprints or impurities burn into the glass and can result in premature failure.
- For this reason, always clean the lamp thoroughly with a cloth moistened with alcohol before installing it.
- Then wipe the UV lamp with a soft, dry cloth.
- Also thoroughly clean the glass of the UV lamp return cable.



INFORMATION: Clean the UV sensor every time you clean the UV lamp protection tube



Safety switch for the UV lamp cover

The UV lamp cover is protected with a safety switch. The safety switch has a reed switch and comprises two components. The safety switch ensures that the UV lamp only generates UV radiation in its fitted state. If the safety switch is removed, then the UV lamp switches off. If the safety switch is not fitted and thus remains closed, e.g. after installation and maintenance work, then the UV lamp cannot be started.

Cleaning after dismantling the UV lamp protection tube

1.  Use [F1] to switch off the UV system.
2.  Close the shut-off valves upstream and downstream of the radiation chamber.

3. ➤ Switch off the main switch or disconnect the system from the mains power supply.
4. ➤ Drain the radiation chamber.
5. ➤ Now first remove the wiper motor, depending on the size of the system.
6. ➤ Remove the safety switch of the UV lamp cover.
7. ➤ Use an Allen key to loosen the fixing bolts of the UV lamp cover and remove the UV lamp cover and the UV lamp.
8. ➤ Place the UV lamp cover and the UV lamp fully to one side.
9. ➤ Loosen the UV lamp protection tube bracket with a face spanner and remove it, placing the spanner on the holes and not on the threads.
10. ➤ Carefully remove the UV lamp protection tube fully out of the radiation chamber and place on a suitable clean surface.
11. ➤ Remove the O-ring from the UV lamp protection tube.
12. ➤ Wash the UV lamp protection tube with cleaning solution or immerse it in cleaning solution until the film has been removed without leaving a trace.
13. ➤ Rinse the UV lamp protection tube with clean water and dry thoroughly with a soft cloth.
14. ➤ Carefully push the UV lamp protection tube into the radiation chamber until it reaches its stop position.
15. ➤ Check the UV lamp protection tube for damage before fitting
 - Never refit a damaged UV lamp protection tube
 - Ensure that the lamp protection tube is seated correctly
 - Make sure that the UV lamp protection tube does not protrude more than 13 mm and is not offset at an angle.

Push a new O-ring onto the end of the UV lamp protection tube.

INFORMATION: Check whether the O-ring on the UV lamp protection tube bracket is seated in the groove provided. Ensure that the sealing surfaces on which the O-ring sits are completely smooth and clean.

16. ➤ Screw the UV lamp protection tube bracket into the chamber cover and manually tighten.
17. ➤ **INFORMATION:** Place the face spanner on the holes and not on the threads. The threads could be damaged irreparably.

Then tighten the UV lamp protection tube bracket using the face spanner provided: tightening angle $90^\circ \pm 5^\circ$.

⇒ **INFORMATION:** Following this, check the leak-tightness of the UV system.
18. ➤ **INFORMATION:** Check that the lamp return cable is not lying between the UV lamp and the UV sensor. The shadow of the lamp return cable could otherwise distort the UV intensity measurement.

Insert the UV lamp into the UV lamp protection tube and allow it to protrude approx. 100 mm.

19. ➤ Fix the UV lamp to the cable clamp with the aid of a slotted head screwdriver.
20. ➤ Insert the UV lamp fully into the UV lamp protection tube.

21. ▶ Place the UV lamp cover onto the UV lamp protection tube bracket and, using the fixing bolts provided, screw in and tighten with the Allen key.
22. ▶ Fit the safety switch of the UV lamp cover.
23. ▶ First fit the wiper motor, depending on the size of the system.
24. ▶ Attach the pin plug with the connection cable for the motor wiper to the socket of the wiper motor and fix in place with the knurled nut.
25. ▶ Connect the cable plugs for the solenoid switch and temperature monitor.
26. ▶ Switch on the main switch or connect the system to the mains power supply.
27. ▶ Slowly open the shut-off valve upstream of the radiation chamber.
28. ▶ Open the shut-off valve downstream of the radiation chamber. Only necessary with a manual shut-off valve.
29. ▶ Use *[F1]* to switch on the UV system.

9.2.3 Cleaning with Cleaning Solution by Filling the UV System



NOTICE!

Handling the cleaning solution

- It is also recommended with reactors, which are regularly cleaned by filling them with a cleaning solution, that the water drain connector and the vent screw are replaced by appropriate valves.
- With larger reactors, it is recommended that they are filled through the water drain opening using an appropriate acid-resistant pump.
- If the reactor is filled with a pump, it is also useful to circulate the cleaning solution through the vent opening.
 - This shortens the cleaning time and achieves a better result.
- If the cleaning solution is collected and stored in a suitable storage tank, it can be reused several times.

Cleaning the lamp protection tubes by filling the reactor with a cleaning solution:

1. ▶ Switch off the UV system.
2. ▶ Switch off the master switch or disconnect it from the mains power supply.
3. ▶ Close the shut-off valves upstream and downstream of the radiation chamber.
4. ▶ Drain the reactor.
5. ▶ Screw in the water drain screw again and tighten using minimal force.
6. ▶ Fill the reactor with the cleaning solution through the vent opening.
 - ⇒ Allow the cleaning solution to work for at least 20 minutes.
7. ▶ Open and remove the water drain screw.

8. ▶ Empty the reactor and dispose of the cleaning solution in accordance with the applicable regulations.
9. ▶ Flush the reactor thoroughly with clean water until all residue of cleaning solution has been removed.
10. ▶ Screw in the water drain screw and tighten using minimal force.
11. ▶ Slowly open the shut-off valve upstream of the reactor.
12. ▶ Fill the reactor until water emerges from the vent screw.
13. ▶ Close the air vent screw and tighten it using minimal force.
14. ▶ Open the shut-off valve downstream of the reactor, which is only necessary with a manual shut-off valve.
 - ⇒ Check the reactor for leaks.
15. ▶ Switch on the master switch or connect to the mains power supply.
 - ⇒ The UV system is ready for operation again.

9.2.4 Cleaning the UV Sensor

1. ▶ Loosen the sensor connection cable from the UV sensor
2. ▶ Turn the UV sensor out of the radiation chamber
3. ▶ Clean the quartz window with a cloth that has been saturated with cleaning solution until the coating has been removed without leaving a trace
4. ▶ Rinse the quartz window with clean water and dry with a soft cloth
5. ▶ Examine the O-ring for damage and replace any damaged seals
6. ▶ Screw in the UV sensor again and tighten; very little effort is needed for this
7. ▶ Connect the sensor connection cable to the UV sensor
8. ▶ Slowly open the shut-off valve upstream of the radiation chamber
9. ▶ Fill the radiation chamber until water emerges from the vent plug
10. ▶ Close the air vent plug and tighten; very little effort is needed for this
11. ▶ Open the shut-off valve downstream of the radiation chamber (only necessary with a manual shut-off valve)
 - ⇒ Check that the radiation chamber is not leaking
12. ▶ Switch on the main switch or connect to the mains power supply
 - ⇒ The UV-system is again ready for operation.

9.3 Maintenance of the wearing parts

9.3.1 Tools

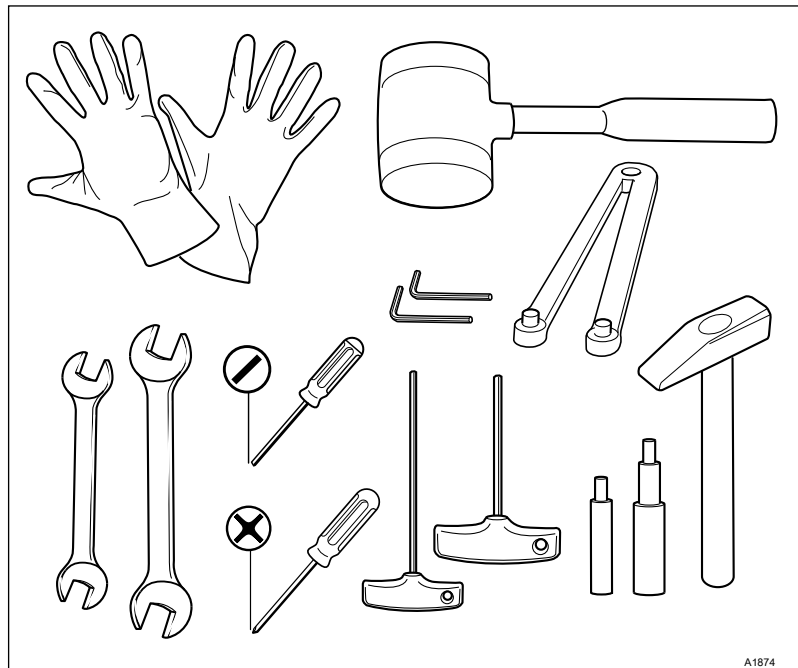

A1874

Fig. 50: Tools

Tools:

- 17 mm open-ended spanner
- 24 mm open-ended spanner
- 1.5 mm Allen key
- 2 mm Allen key
- 5 mm Allen key
- 6 mm Allen key
- 300 gramme hammer
- Plastic hammer
- Face spanner for Ø 14 ... 100 mm
- Screw driver, slotted
- Screw driver, Philips

9.3.2 Replacing wearing parts after an operating period of one year



Spare parts kit

This chapter describes all the working steps needed to individually or completely replace all the components in the spare parts kit.

There are different spare parts kits depending on the number and type of UV lamps fitted:

- Part number 1042860: Spare parts kit UVA 1x1/1x2/1x3 kW / motor wiper
- Part number 1044862: Spare parts kit UVA 2x2/2x3 kW / motor wiper
- Part number 1044863: Spare parts kit UVA 3x3 kW / motor wiper

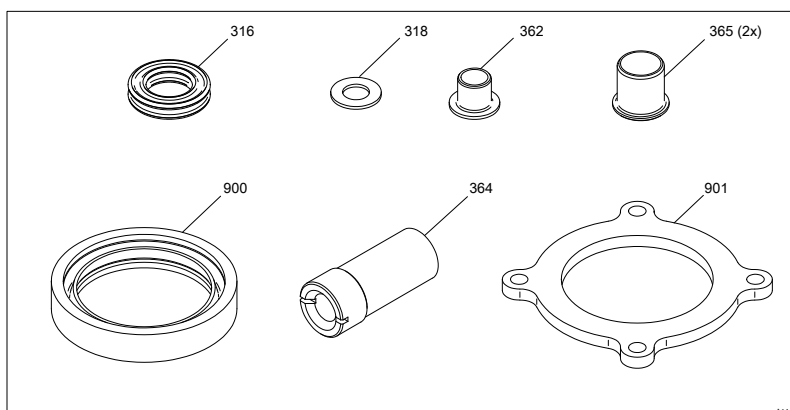

Fig. 51: Replace these components after an operating period of one year. The number of components varies depending on the type of the spare parts kit.

- 316 X-ring
- 318 Slip washer
- 362 Slide bearing
- 365 Slide bearing (2 no.)
- 901 Holding ring
- 364 Threaded sleeve
- 900 Wiper element

9.3.3 Instructions: Replacing the wearing parts



WARNING!

Live parts!

Possible consequence: Fatal or very serious injuries

- Measure: Disconnect the device from the power supply before opening it
- Disconnect damaged and defective devices or devices that have been tampered with from the power supply
- Do not modify the fitted UV lamp connection cable without authorisation



WARNING!

Consequence: Serious injuries.

UV-C radiation is harmful to the eyes and skin

- Only start up the UV lamp  when it is properly installed
- Install the UV lamp into the UV system in accordance with the regulations prior to commissioning





CAUTION!

Fingerprints on the UV lamp

Possible consequence: Premature failure of the UV lamp

- Only touch the glass of the UV lamp when wearing cotton gloves
- Fingerprints or impurities burn into the glass and can result in premature failure
- For this reason always clean the lamp thoroughly with a cloth moistened with alcohol before installing it
- Then wipe the UV lamp with a soft, dry cloth
- Also thoroughly clean the glass of the UV lamp return cable

Dismantling

1.  Use the START/STOP key to switch off the UV system. Switch the main switch off or disconnect the mains plug from the power supply.
2.  Close the shut-off valves upstream and downstream of the radiation chamber.

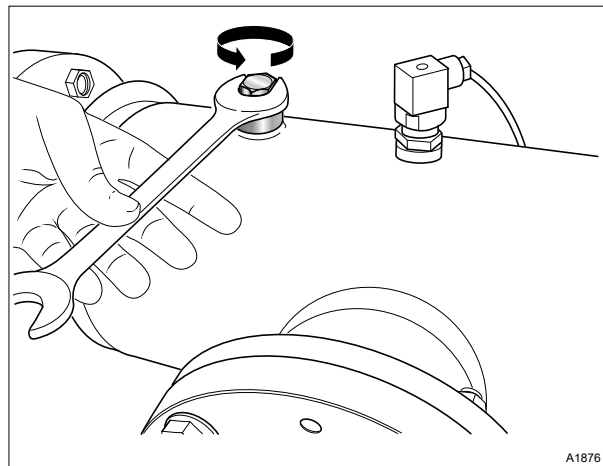

Fig. 52: Upper sealing stopper

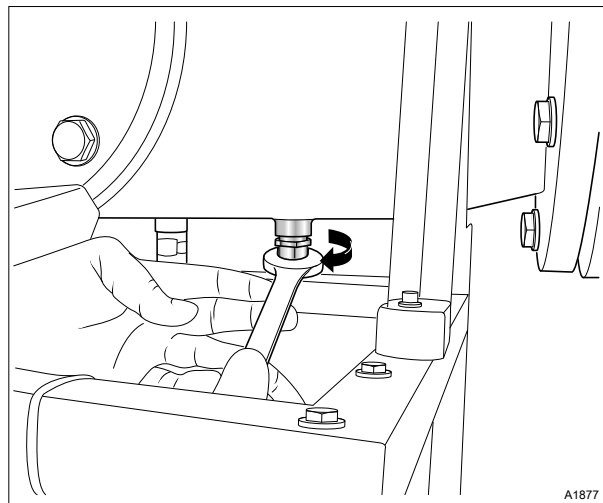

Fig. 53: Lower sealing stopper

3. ➤ Drain the radiation chamber by removing the upper and lower sealing stoppers.

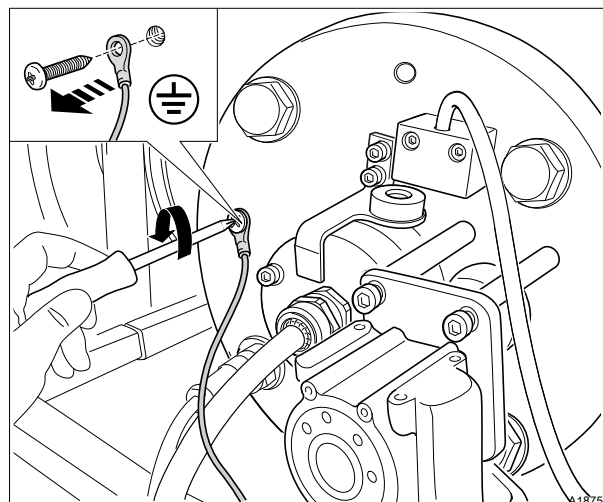

Fig. 54: Earthing cable

4. ➤ Remove the earthing cables

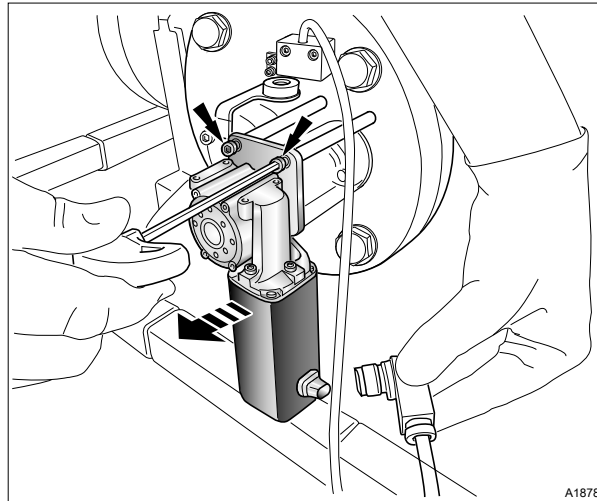

Fig. 55: Flange plate

5. ➤ Dismantle the flange plate with the wiper motor.

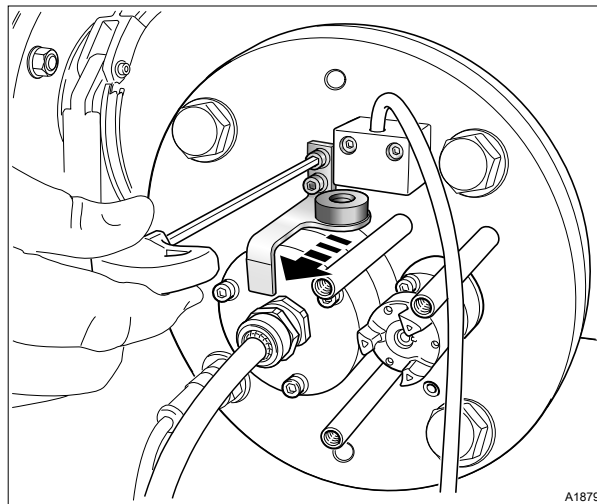

Fig. 56: Safety switch

6. ➤ Remove the UV lamp cover safety switch.

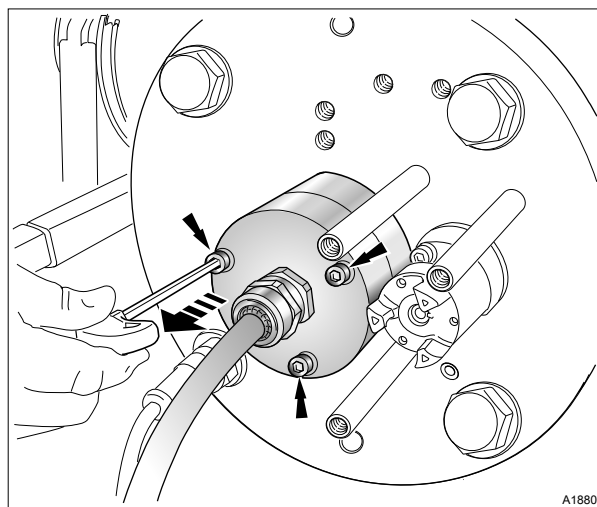

Fig. 57: UV lamp cover

7. ➤ Loosen the fixing bolts on the UV lamp cover.

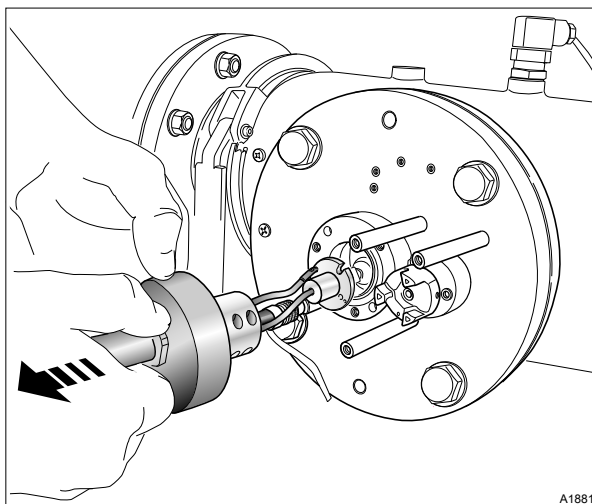

Fig. 58: UV lamp cover / UV lamp

- 8.** → Remove the UV lamp cover and the UV lamp

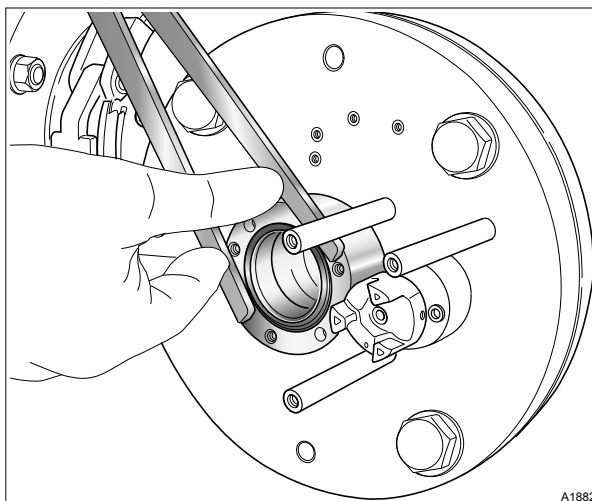

Fig. 59: Tool

- 9.** → Loosen and remove the UV lamp protection tube bracket
Place the toll on the holes and not on the threads.

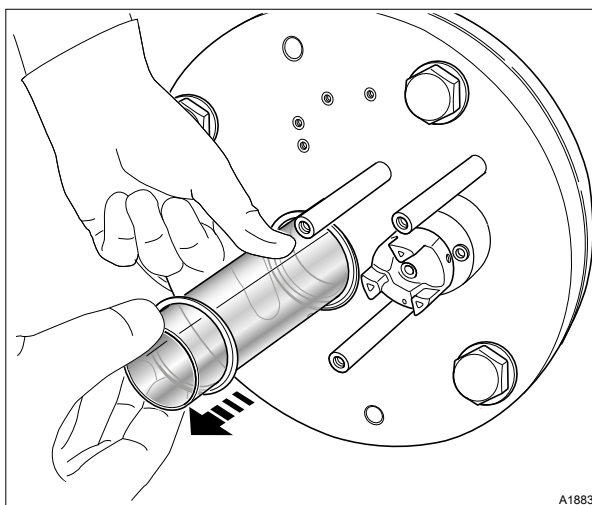

Fig. 60: UV lamp protection tube

- 10.** → Remove the UV lamp protection tube from the radiation chamber.

11. ▶ Rinse the UV lamp protection tube with clean water and thoroughly dry the UV lamp protection tube with a soft cloth. Chemically clean the UV lamp protection tube if necessary (refer to the Operating Instructions).

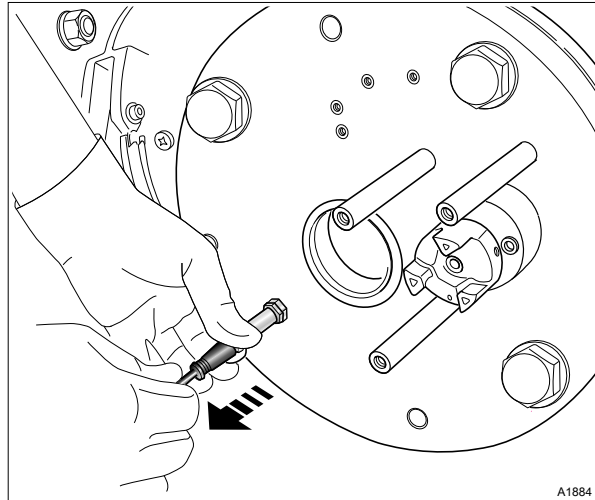

Fig. 61: Wiper limit switch

12. ▶ Remove the cable from the wiper limit switch

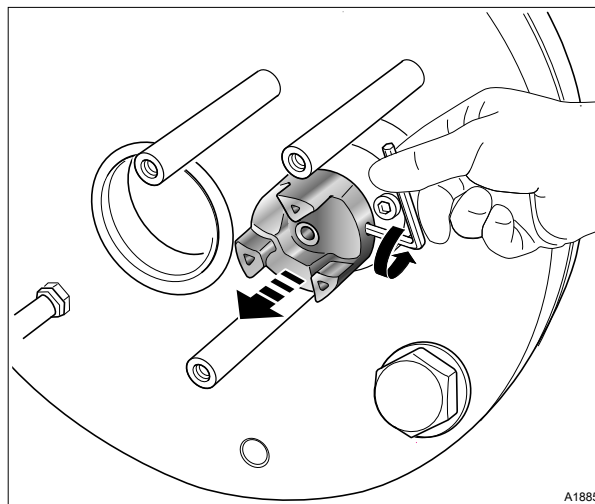

Fig. 62: Coupling / Splint

13. ▶ Remove the coupling and remove the splint.

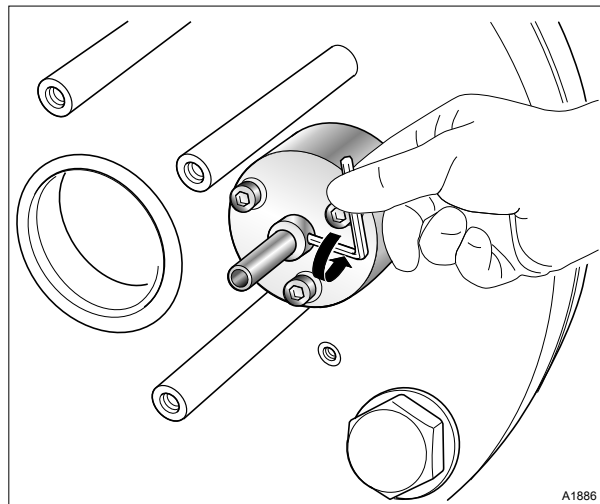

Fig. 63: Spacer ring / Slip washer

14. ➤ Remove the spacer ring and the slip washer.

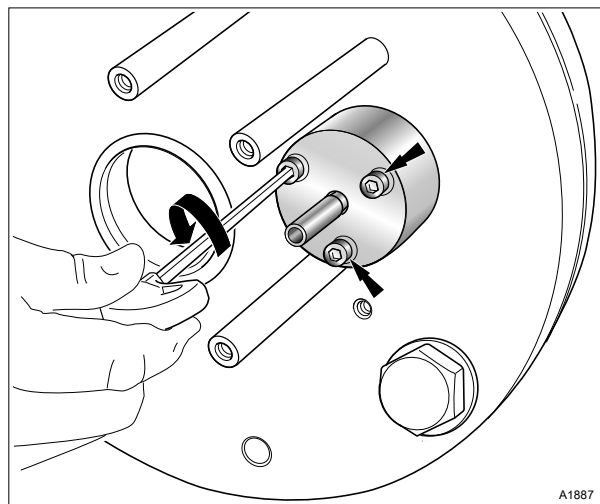

Fig. 64: Bearing cover

15. ➤ Unscrew the screws on the bearing cover.

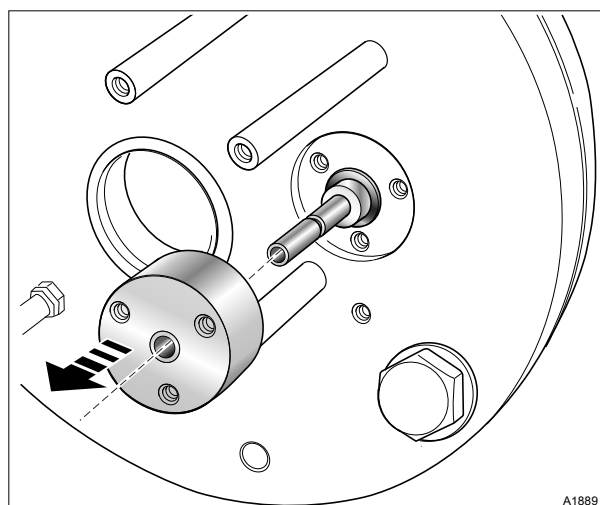

Fig. 65: Bearing cover

16. ➤ Remove the bearing cover from the chamber cover.

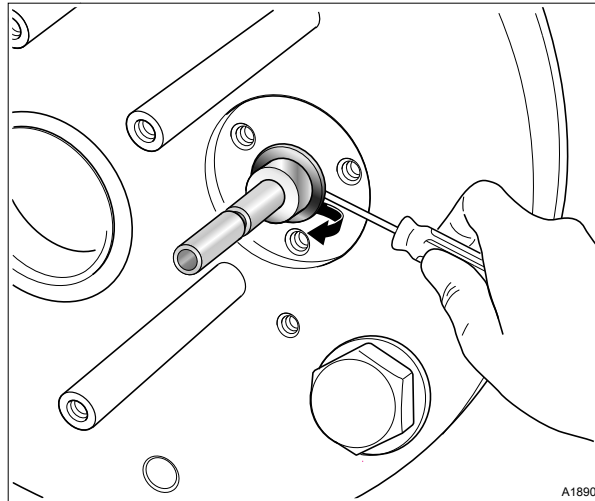

Fig. 66: X-ring

- 17. ▶ Remove the old X-ring and clean all components
- 18. ▶ Grease the new X-ring using CARBAFLO® 2371 and insert the new X-ring into the chamber cover.

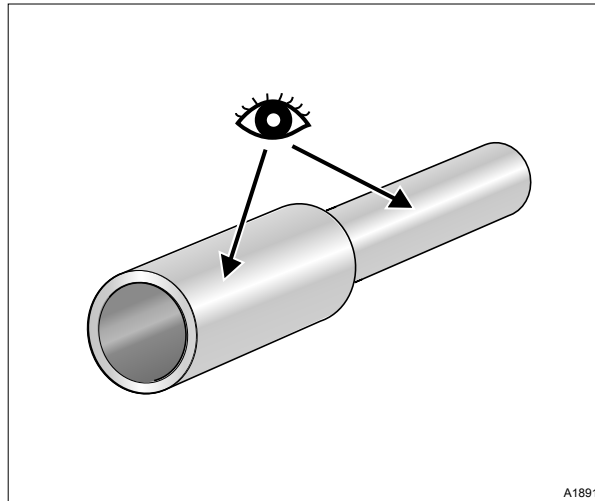

Fig. 67: Checks

- 19. ▶ Check and if necessary replace the adapter shaft. The shaft should not have any grooves or unevenness.

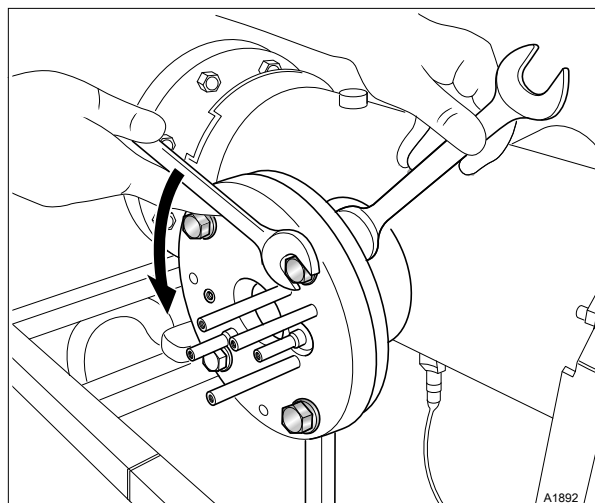

Fig. 68: Screws / Chamber cover

- 20. ▶ Remove the screws of the chamber cover.

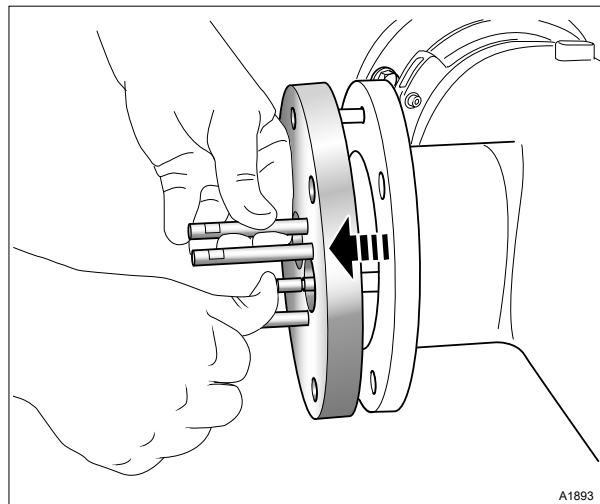

Fig. 69: Chamber cover

21. ➤ Remove the chamber cover.

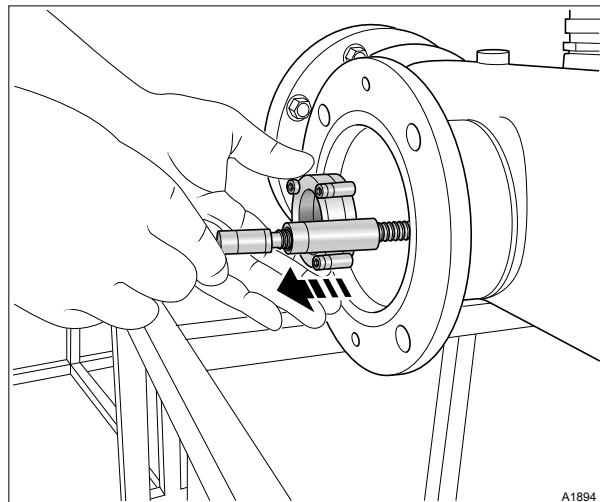

Fig. 70: Wiper assembly with spindle

22. ➤ Remove the wiper assembly with spindle.

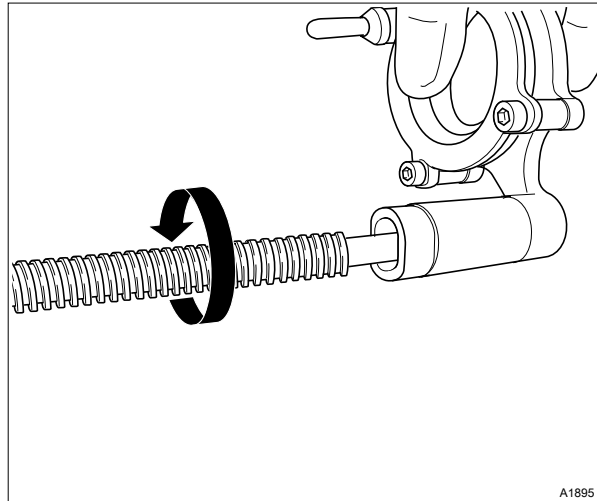

Fig. 71: Wiper spindle

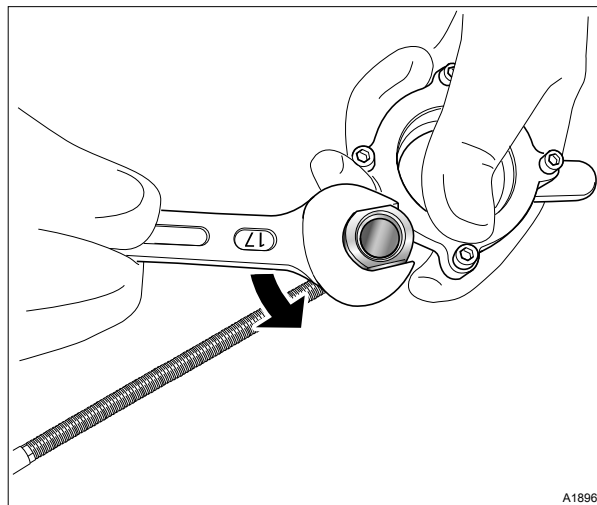

Fig. 72: Wiper spindle

23. ➤ Remove the wiper assembly from the wiper spindle.

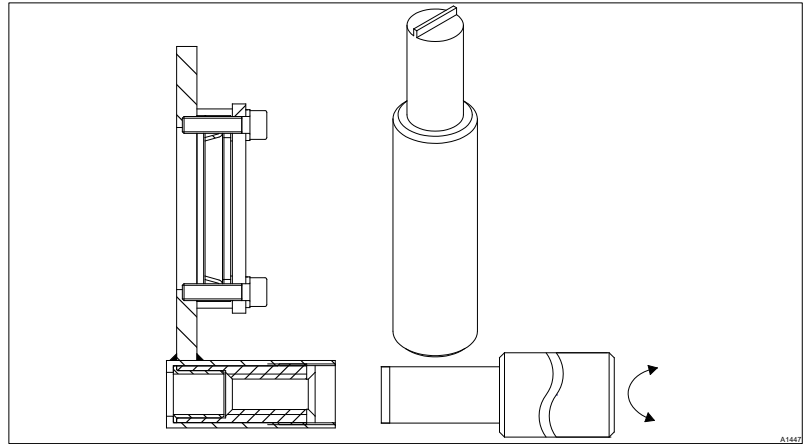

Fig. 73: Tool for the threaded sleeve in the wiper mounting, part number 1037738

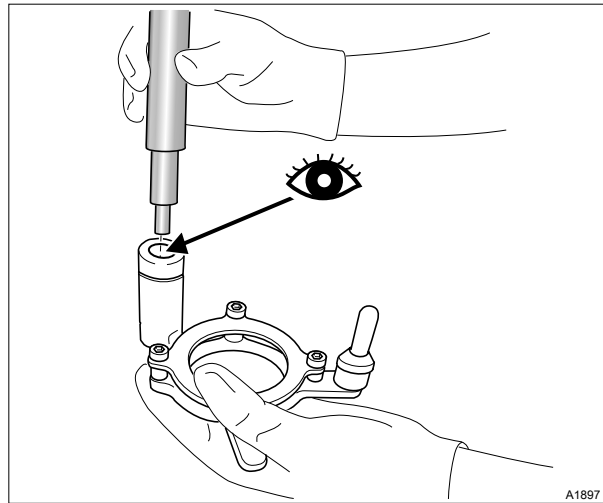

Fig. 74: Checking the threaded sleeve

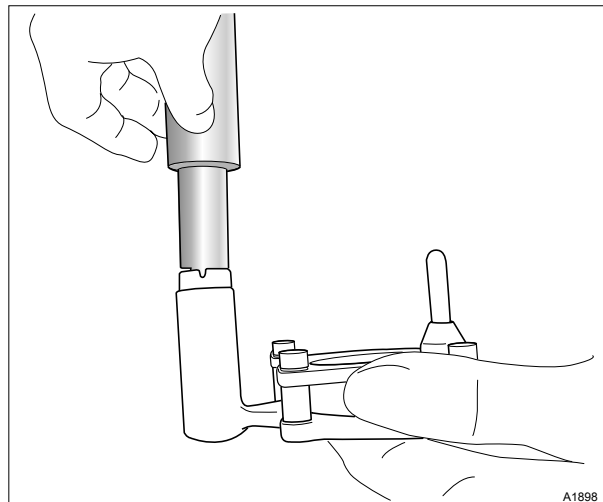

Fig. 75: Unscrewing the threaded sleeve

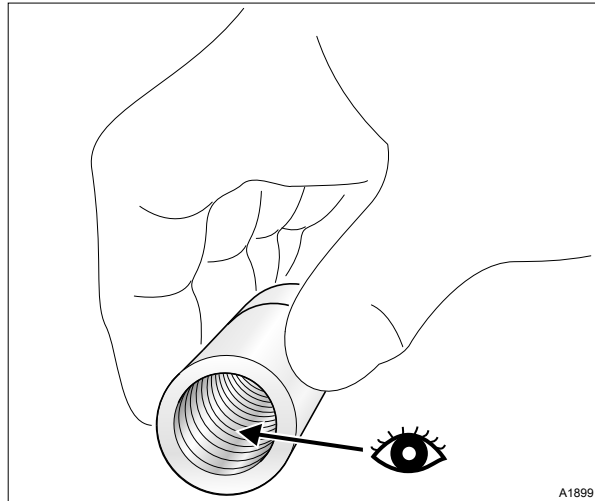

Fig. 76: Checking the threaded sleeve

- 24.** Check and if necessary replace the threaded sleeve in the wiper mounting.

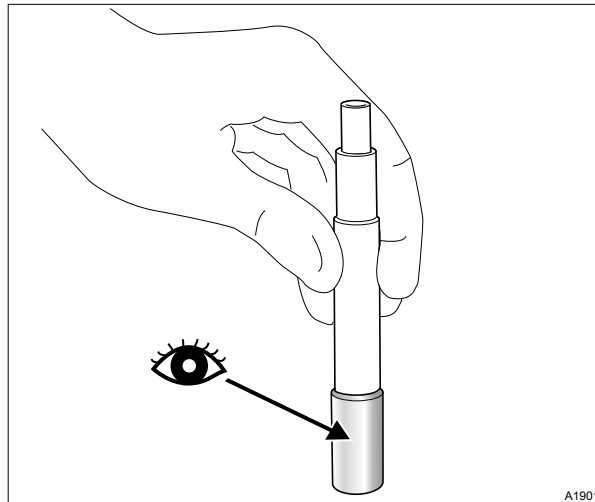

Fig. 77: Plastic slide bearing

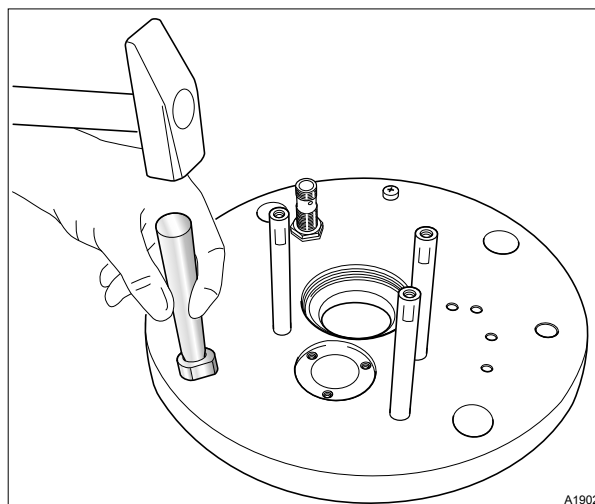

Fig. 78: Plastic slide bearing

- 25.** Check and if necessary replace the plastic slide bearings.

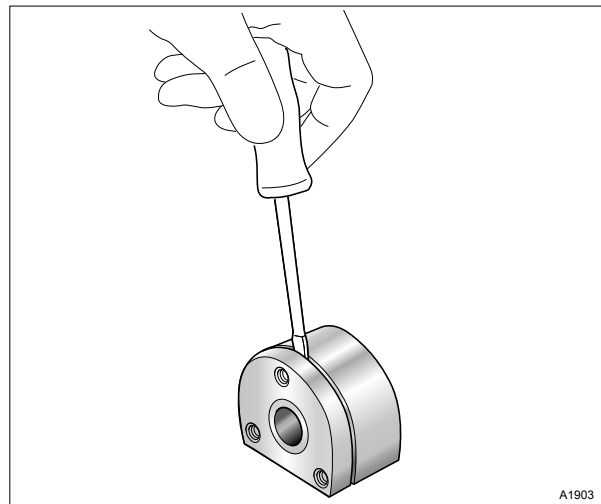

Fig. 79: Bearing cover

26. ▶ Open the bearing cover to obtain access to the slide bearing.

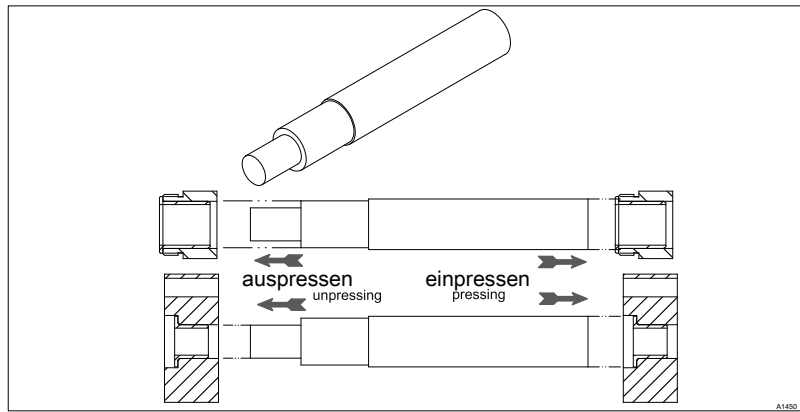

Fig. 80: Tool for pressing in and out the plastic slide bearings, part number 1036907

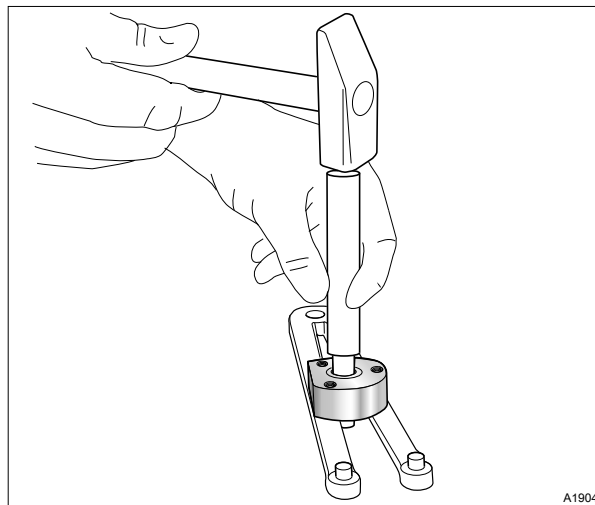

Fig. 81: Bearing cover slide bearing

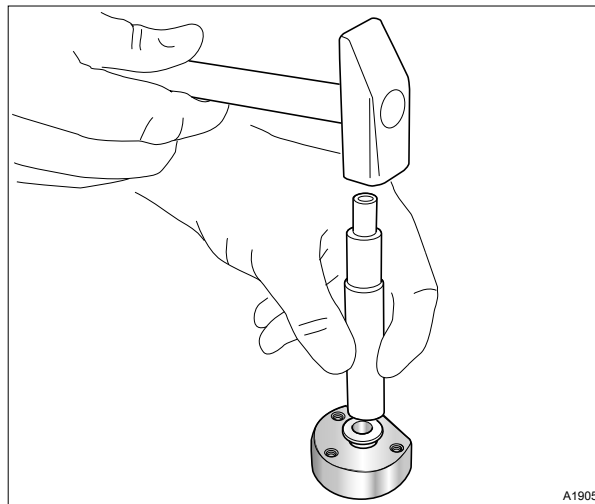

Fig. 82: Bearing cover slide bearing

27. ▶ Replace the slide bearing of the bearing cover.

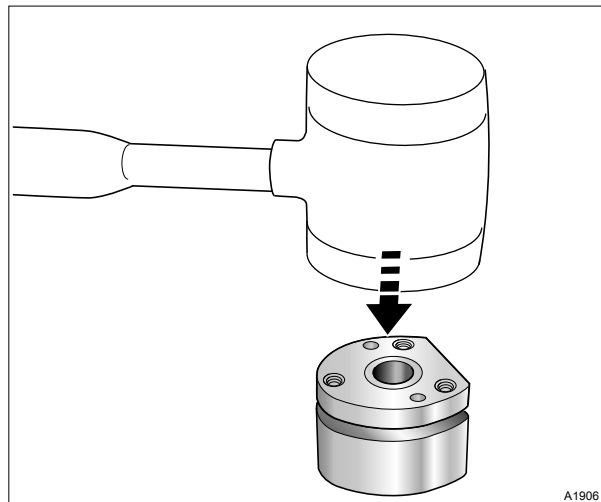

Fig. 83: Bearing cover

28. ➤ Close the bearing cover.

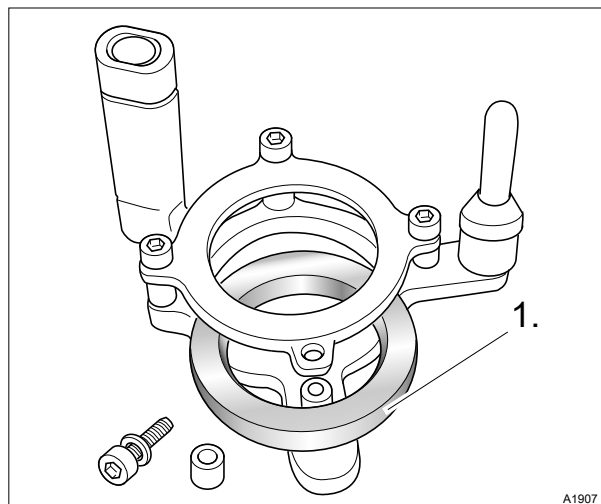

Fig. 84: Wiper element (1)

29. ➤ Check and if necessary replace the wiper element (1).

The wiper lip points away from the chamber cover, to simplify the insertion of the UV lamp protection tube.

⇒ When assembled, the wiper element should be mounted so it floats and can move.

Replace the wiper counter-bearing after 5 years

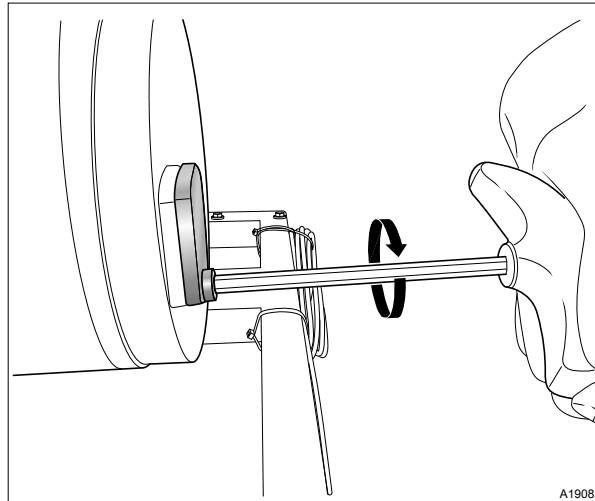

Fig. 85: Counter-bearing

30. ▶ Remove the bolts that fix the counter-bearing

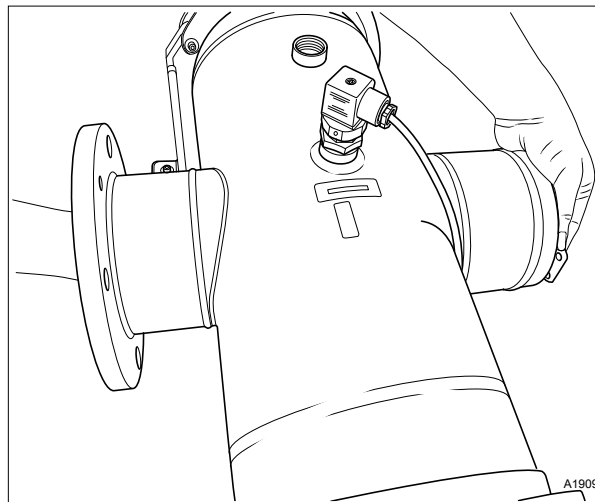

Fig. 86: Counter-bearing

31. ▶ Remove the counter-bearing by pressing it out from inside.

Reassembling the unit

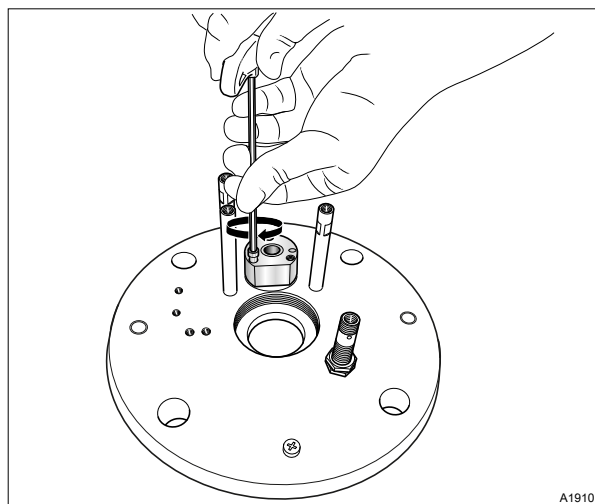

Fig. 87: Bearing cover / chamber cover

32. ▶ Use the screw to screw the bearing cover to the chamber cover.

⇒ The flat area points towards the UV lamp

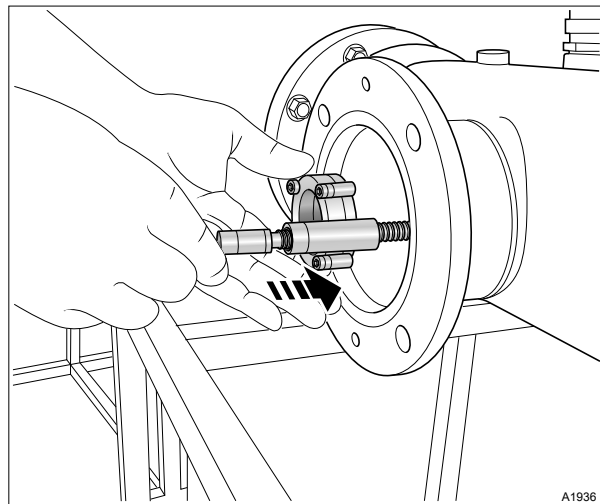

Fig. 88: Wiper rod

- 33.** Push the wiper rod through the UV chamber cover into the counter-bearing.

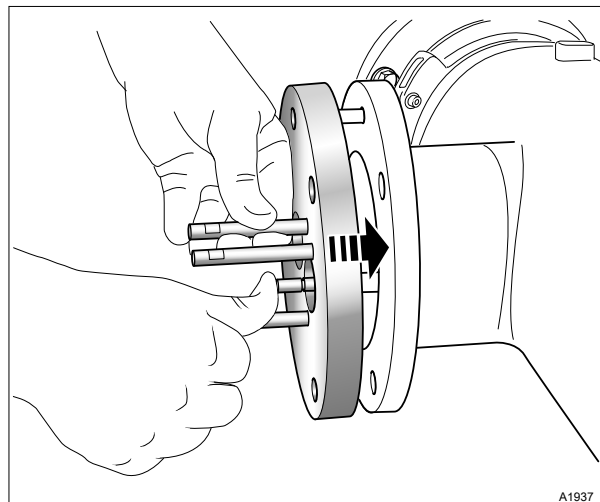

Fig. 89: Chamber cover

- 34.** Push the chamber cover onto the radiation chamber.
⇒ The wiper rod has to site in the bearings.

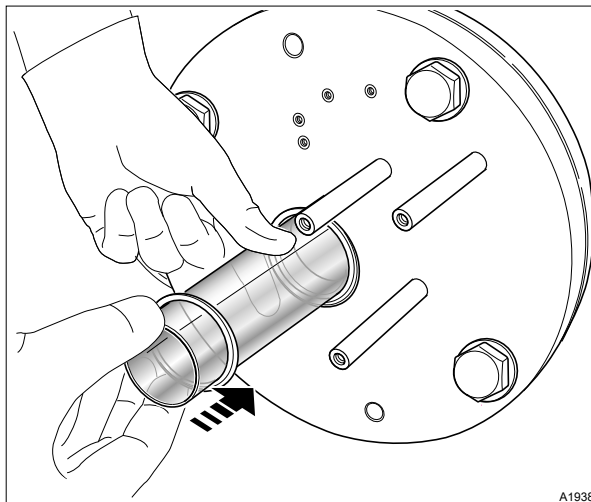

Fig. 90: UV lamp protection tube / O-ring

- 35.** Fit the UV lamp protection tube using a new O-ring. Screw the UV lamp protection tube bracket into the chamber cover until hand-tight.

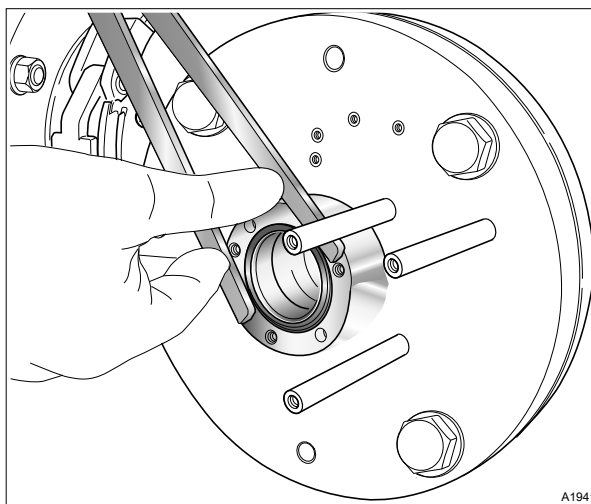

Fig. 91: Tightening torque $90^\circ \pm 5^\circ$

- 36.** Tighten the UV lamp protection tube bracket.
⇒ Tightening torque $90^\circ \pm 5^\circ$

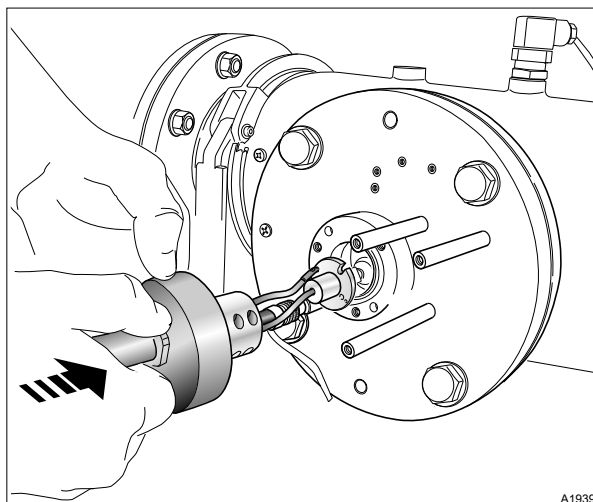

Fig. 92: UV lamp

37. ▶

**Position of the lamp return cable.**

Check that the lamp return cable is not lying between the UV lamp and the UV sensor. The shadow of the lamp return cable could otherwise distort the measurement of the UV intensity.

Fit the UV lamp.

38. ▶ Fit the safety switch

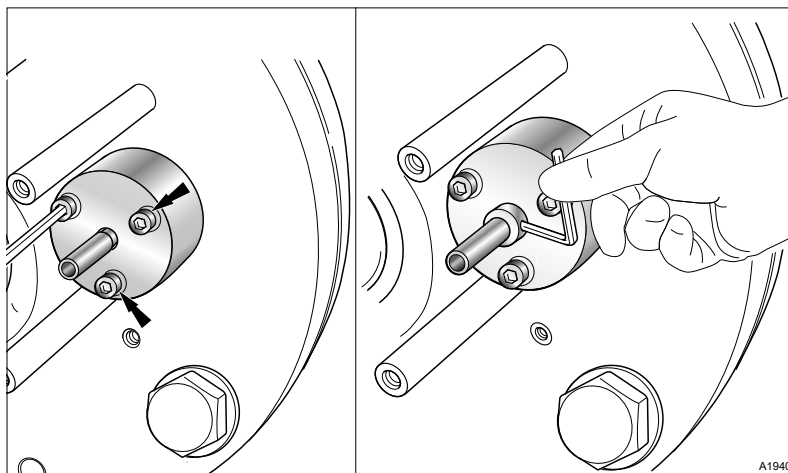

Fig. 93: Coupling

39. ▶ Attach the slip washer, the spacer ring and feather key and fit the coupling

Fit the spacer ring. Place the coupling on gently, do not tighten the screws.

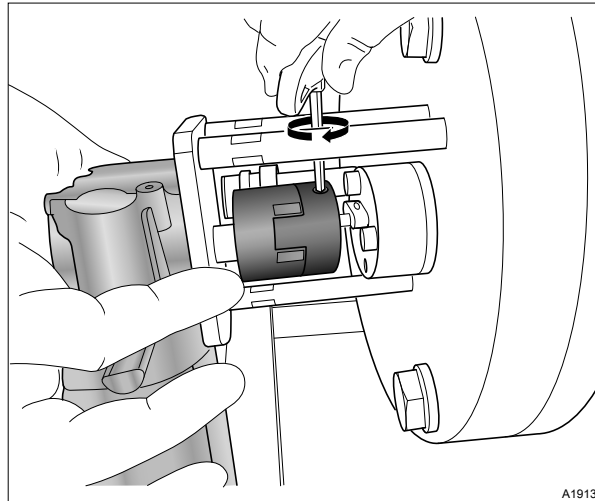

Fig. 94: Wiper motor on the coupling

- 40. ▶ Place the wiper motor onto the coupling
Position the coupling and tighten the screw.

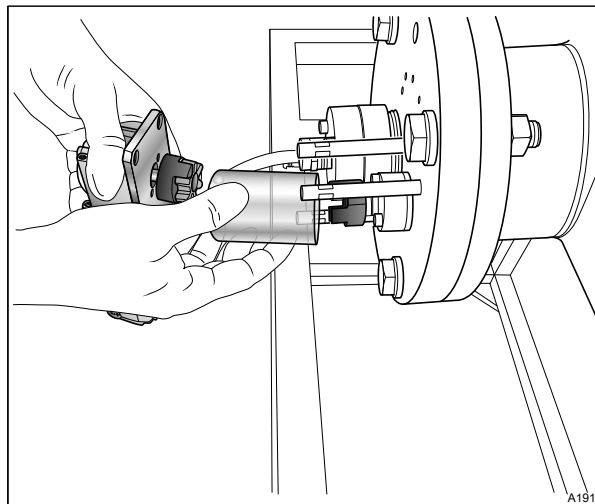

Fig. 95: Protective cover on the coupling

- 41. ▶ Remove the wiper motor, push the protective cover over the coupling. Then push the wiper motor onto the coupling again and fix the wiper motor in place.
- 42. ▶ Connect up all electrical connections
- 43. ▶ Seal the radiation chamber by screwing in the upper and lower sealing stoppers.
- 44. ▶ Slowly open the shut-off valves upstream and downstream of the radiation chamber, fill the UV radiation chamber with water and vent the UV radiation chamber as necessary.
- 45. ▶ Switch the main switch on and/or connect the mains plug to the power supply
- 46. ▶ Switch the UV system on
- 47. ▶ Assemble the UV system in reverse order.
 - ⇒ Note the information in the operating instructions.

Restart the UV system

9.4 Replacing the lamp

**WARNING!****Live parts!**

Possible consequence: Fatal or very serious injuries

- Measure: Disconnect the device from the power supply before opening it
- Disconnect damaged, defective devices or devices that have been tampered with from the power supply

**WARNING!****UV-C radiation**

Possible consequence: Serious injuries.

UV-C radiation is harmful to the eyes and skin

- Only start up the UV lamp  when it is properly installed
- Install the UV lamp into the UV system in accordance with the regulations prior to commissioning

**WARNING!****Insufficient treatment efficiency**

Possible consequence: Illness

Please read the Technical Data Sheet enclosed with the respective UV system!

- Replace the UV lamps with new lamps at the very latest when:
 - The UV sensor signal approaches the safety threshold without this being due to other causes, such as the formation of a coating on the UV lamp protection tubes or a serious deterioration of the UV-transmission;
 - The operating life of the UV lamp is approaching the maximum service life of the lamp or has exceeded it.

**CAUTION!****Fingerprints on the UV lamp**

Possible consequence: Premature failure of the UV lamp

- Only touch the glass of the UV lamp with cotton gloves
- Fingerprints or impurities burn into the glass and can result in premature failure
- For this reason always clean the lamp thoroughly with a cloth moistened with alcohol before installing it
- Then wipe the UV lamp with a soft, dry cloth
- Also thoroughly clean the glass of the UV lamp return cable



NOTICE!

Clean the lamp protection tubes each time a lamp is replaced.

Dispose of used lamps in accordance with the applicable guidelines and directives. Usually these can be disposed of together with used fluorescent tubes.



Safety switch for the UV lamp cover

The UV lamp cover is protected with a safety switch. The safety switch has a reed switch and comprises two components. The safety switch ensures that the UV lamp only generates UV radiation in its fitted state. If the safety switch is removed, then the UV lamp switches off. If the safety switch is not fitted and thus remains closed, e.g. after installation and maintenance work, then the UV lamp cannot be started.

1. ➤ Switch off the UV system
2. ➤ Switch off the main switch or disconnect it from the mains power supply
3. ➤ Close the shut-off valves upstream and downstream of the radiation chamber
4. ➤ Remove the safety switch of the UV lamp cover
5. ➤ Depending on the system size, now first remove the wiper motor
6. ➤ Loosen the fixing bolts of the lamp cover using an Allen key, remove the lamp cover and pull out the lamp by approximately 100 mm
7. ➤ Loosen the UV lamp at the cable clamp with the aid of a slotted head screw driver
8. ➤ Fully remove the UV lamp and place it to one side
9. ➤ Check whether the O-ring on the UV lamp protection tube bracket is in the groove provided - ensure that the sealing surfaces of the O-ring are completely smooth and clean!

10. ➤



Position of the lamp return cable.

Check that the lamp return cable is not lying between the UV lamp and the UV sensor. The shadow of the lamp return cable could otherwise distort the measurement of the UV intensity.

Insert the new UV lamp into the UV lamp protection tube and allow it to project out approx. 100 mm

11. ➤ Fix the UV lamp to the cable clamp with the aid of a slotted head screw driver
12. ➤ Insert the UV lamp fully into the UV lamp protection tube
13. ➤ Place the UV lamp cover onto the UV lamp protection tube bracket and, using the fixing bolts provided, screw in and tighten with an Allen key
14. ➤ Fit the safety switch of the UV lamp cover.
15. ➤ Depending on the system size, now fit the wiper motor

16. ➤ Switch on the main switch or connect up to the mains power supply
17. ➤ Slowly open the shut-off valve upstream of the radiation chamber
18. ➤ Open the shut-off valve downstream of the radiation chamber (only necessary with a manual shut-off valve)
19. ➤ Switch on the UV system

**WARNING!****Insufficient treatment efficiency**

Possible consequence: Death or illness

Check safety and warning threshold.

Check and possibly reset the safety and warning threshold when the UV lamp is replaced.

Only a correctly adjusted safety threshold will guarantee adequate treatment.

***Calibration of the UV sensor***

Calibrate the UV sensor once the UV system has been switched on.

9.5 Calibration of the UV sensor

**NOTICE!**

Only a correctly calibrated UV sensor guarantees adequate water treatment.

Ensure that water to be disinfected is flowing through the radiation chamber when calibrating the UV sensor.

Always calibrate the UV sensor with new UV lamps.

Operate the UV lamps at maximum power when calibrating the UV sensor.

The safety threshold and warning threshold are no longer monitored when calibrating the UV sensor.

9.5.1 [Sensor calibration]



Sensor calibration

Only calibrate the sensor with a cleaned UV system and new UV lamps.

The UV sensor is factory-calibrated and does not usually require any further calibration. A sensor calibration has to be undertaken if the displayed sensor signal deviates significantly from the reference radiation intensity stated in the data sheet. The minimum radiation intensity cannot therefore be achieved. You must set the minimum radiation intensity correctly to monitor the UV radiation intensity.

You can calibrate the unit sensor in this menu should the unit sensor deviate from a reference measurement with a calibrated UV sensor.

The UV signal must not change again before the calibration. A changing UV sensor signal indicates that the UV lamp has not yet warmed up sufficiently. Allow the activated UV system to warm up for a short while.



The calibration process can be terminated at any time by pressing [F1], [F2] and [F5]. The UV system then continues working with the values of the last valid calibration and issues an error message under certain circumstances.

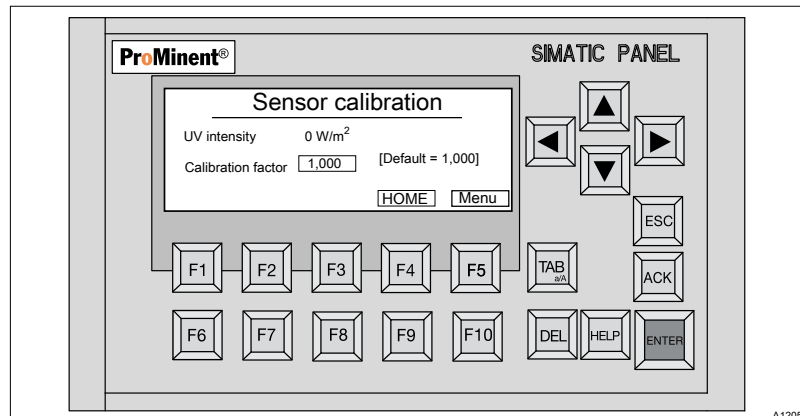

Fig. 96: Calibration of the UV sensor

9.6 Replacing the Filter Mats

Replacement of the filter mats on the fan and the air outlet filter



CAUTION!

General safety measures

Dirty filter mats on the fan and air outlet filter can lead to the control cabinet overheating and becoming damaged

Replace the filter mats on the fan and the air outlet filter at least once per year. The filter mats should be replaced at shorter intervals in unfavourable ambient conditions.

1. ➤ switch off the UV system
2. ➤ Switch off the main switch

3. ➤ Remove the fan cover
4. ➤ Remove the dirty filter mat and insert a new filter mat
5. ➤ Replace the filter mat on the air outlet filter as described above
6. ➤ Switch on the main switch

10 Troubleshooting

- **User qualification:** instructed user, see  Chapter 3.2 'User qualification' on page 12



Display background lighting

To ensure easy monitoring of the UV system operation, the background lighting of the display changes according to the UV system operating status.

- *Normal operation: green lighting*
- *Warning: yellow lighting*
- *Fault: red lighting*

Error messages

Message text	Cause	Solution
Check/Reset breaker 1F5 or 1F6 - 24 V DC!	Breaker 1F5 or 1F6 - 24 V DC has been triggered	Check breaker 1F5 or 1F6 - 24 V DC, rectify defect, where necessary, and reactivate breaker
Temperature of control cabinet above 45 °C!	Inadequate cooling of the control cabinet by: <ul style="list-style-type: none"> ■ Used filter mat ■ Defective fan ■ High ambient temperature ■ Air inlet and/or outlet not guaranteed 	Eliminate the source of the error and monitor the result
External fault!	Contact input for external fault activated	Check connected systems for external fault and eliminate external fault
Lamp driver 1/2/3 - Fan fault	Fan lamp driver 1/2/3 dirty or faulty	Inspect and clean fan or replace lamp driver
Lamp driver 1/2/63 - Cooling temperature	Fault on cooling system or fan	Check cooling system and fan, replacing lamp driver if necessary
Lamp driver 1/2/3 - Input voltage fault	Input voltage outside of the specification	Check power supply
Lamp driver 1/2/3 - Lamp open	UV lamp defective	Replace the UV lamp
Lamp driver 1/2/3 - Lamp short-circuit	UV lamp defective	Replace the UV lamp
Lamp driver 1/2/3 - Error	Lamp driver not ready for operation or defective	Switch UV system off and on, replace lamp driver
System not configured	Parameter set for system not configured (set at the factory)	Contact service technician. An incorrect parameter set can lead to defects on the UV system
Water temperature exceeding 65 °C!	Overheating of the water temperature in the radiation chamber due to stagnation or low water flow	Ensure water flow
Wiper motor!	Wiper motor reports a defect	<ul style="list-style-type: none"> ■ Check wiper motor (electrical and mechanical) and replace if necessary. ■ The UV system can continue running by disabling the wiper (wiper interval = 0) until the cause is eliminated.
Wiper motor counter	The counter on the wiper motor reports an error	<ul style="list-style-type: none"> ■ Check the wiring, re-calibrate the wiper, replacing wiper motor if necessary. ■ The UV system can continue running by disabling the wiper (wiper interval = 0) until the cause is eliminated.

Message text	Cause	Solution
Wiper motor proximity switch!	The proximity switch for the ' <i>HOME position</i> ' of the wiper motor does not switch	<ul style="list-style-type: none"> ■ Check the position of the wiper and the solenoid switch on the wiper mechanism ■ Check cabling. ■ Perform a functional check of the proximity switch and wiper mechanism, replacing the proximity switch if necessary ■ The UV system can continue operation by disabling the wiper (wiper interval = 0) until the cause is eliminated
Overheating - lamp is cooling	Overheating of the water temperature in the radiation chamber. System has switched off	Ensure water flow
Wiper is not calibrated!	Wiper is not calibrated	Calibrate wiper
Wiper not at HOME position!	Wiper does not reach the ' <i>HOME position</i> ' within the maximum runtime.	<ul style="list-style-type: none"> ■ Move wiper to the '<i>HOME position</i>' ■ Check the position of the wiper and the solenoid switch on the wiper mechanism
UV intensity below safety threshold!	<ul style="list-style-type: none"> ■ UV intensity below the minimum radiation intensity ■ UV lamp has aged and UVC power too low ■ Low transmission of the water ■ Dirt on the lamp protection tube ■ Dirt on the UV sensor, faulty UV sensor 	<ul style="list-style-type: none"> ■ Replace UV lamp. check transmission of the water or improve pre-treatment, if necessary, or adjust system settings to water quality ■ Trigger wiper cycle, manually clean lamp protection tube if necessary ■ Clean the UV sensor, replace UV sensor
UV lamp safety switch open!	Safety switch removed or faulty	Repair safety switch

Warning messages

Message text	Cause	Solution
Low UV intensity after wiper cycle	<ul style="list-style-type: none"> ■ UV intensity is still low after wiping ■ UV lamp has aged and UVC power too low ■ Low transmission of the water ■ Stubborn dirt on the radiator protection tube and insufficiently removed by wiping cycle ■ Dirt on UV sensor, faulty UV sensor 	<ul style="list-style-type: none"> ■ Replace the UV lamp ■ Check the transmission of the water and improve pre-treatment, if necessary, or adjust system settings to water quality ■ Manually clean the lamp protection tube ■ Clean the UV sensor, replace UV sensor
UV intensity below warning threshold!	<ul style="list-style-type: none"> ■ UV intensity below the warning threshold ■ UV lamp has aged and UVC power too low ■ Poor transmission of the water ■ Dirt on the lamp protection tube ■ Dirt on UV sensor, faulty UV sensor 	<ul style="list-style-type: none"> ■ Replace the UV lamp ■ Check the transmission of the water and improve pre-treatment, if necessary, or adjust system settings to water quality ■ Manually clean the lamp protection tube ■ Clean the UV sensor, replace UV sensor
Unit must be OFF to manually control wiper!	Manual movement of the wiper is only permitted when the UV system is switched off	Switch off the UV system

11 Technical data

Performance data



NOTICE! Data sheet

This technical data supplements the enclosed data sheet. If in doubt, the information on the data sheet and the wiring diagram applies.

Type	Number of lamps	Lamp power	Connected power
1x1A	1	1.00 kW	1.10 kW
1x2A	1	2.00 kW	2.10 kW
1x3A	1	3.00 kW	3.20 kW
2x2A	2	4.00 kW	4.20 kW
2x3A	2	6.00 kW	6.20 kW
3x3A	3	9.00 kW	9.20 kW

Type	Max. flow*		Connector	
			Selectable nominal width	
1x1A	56 m ³ /h	245 GPM	DN 100	ANSI 4"
1x2A	95 m ³ /h	418 GPM	DN 150	ANSI 6"
1x3A	180 m ³ /h	794 GPM	DN 200	ANSI 8"
2x2A	241 m ³ /h	1059 GPM	DN 200	ANSI 8"
2x3A	361 m ³ /h	1588 GPM	DN 250	ANSI 10"
3x3A	541 m ³ /h	2382 GPM	DN 300	ANSI 12"

* 95%/cm transmission; 600 J/m²

Type	Pressure loss at maximum flow		Minimum clearance for Maintenance work	Empty weight / Operating weight Radiation chamber	Volume
	mbar	psi			
1x1A	15 mbar	0.22 psi	400 mm	31 kg / 47 kg	15 l
1x2A	17 mbar	0.25 psi	500 mm	38 kg / 65 kg	25.5 l
1x3A	6 mbar	0.1 psi	600 mm	52 kg / 118 kg	57.4 l
2x2A	10 mbar	0.15 psi	1000 mm	78 kg / 166 kg	76.2 l
2x3A	18 mbar	0.26 psi	1000 mm	78 kg / 166 kg	76.2 l
3x3A	27 mbar	0.4 psi	1000 mm	78 kg / 166 kg	80.8 l



NOTICE!

If the UV system is stored as an assembly together with the sensors, pumps etc., then the storage and transport conditions should be appropriate for the component with the least resistance to external influences.

Permissible operating temperatures:

- Water temperature: 5 ... 40 °C
- Ambient temperature: 5 ... 40 °C



Operating pressure*

The maximum permissible operating pressure is possibly lower with systems that have a non-standard design, see data sheet for the UV system.

Requirements for the water to be treated:

- Maximum temperature: 40 °C
- Maximum operating pressure: 7 ... 10 bar, depending on UV system type
- No corrosive or abrasive properties, chloride content < 800 ppm
- No tendency for sedimentation

Sound pressure level

The sound pressure level is < 70 dB (A)

11.1 Dimensions Sheet

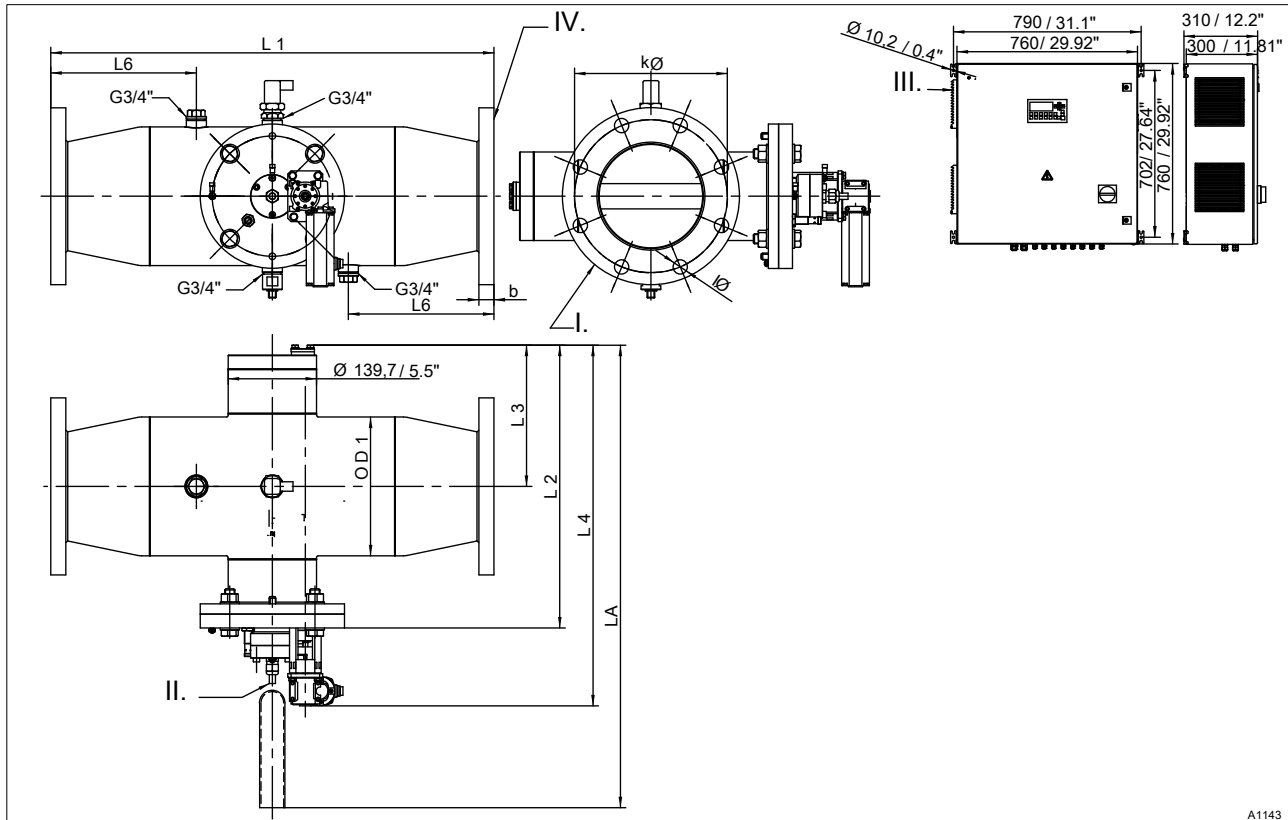

A1143

Fig. 97: Dimensions sheet for single lamp systems

Type	1 kW-ANSI	1 kW-DIN
DN	4"	100
D1	6.63"	168.3
L1	27.56"	700.0
L2	13.66"	347
L3	6.81"	173
L4	18.5"	470
L6	9.06"	230.0
LA	26.14"	664
kØ	7.5"	180
IØ	0.75"	18
b	0.87"	20
I.	ANSI 150 lbs compatible or DIN 2576	
II.	Cable length approx. 9 metres / 354"	
III.	Wall clearance at least 300 mm / 12"	
IV.	ANSI 150 lbs compatible or DIN 2576	

Drawings not true to scale.

(All dimensions in "mm"), unless otherwise indicated.

Type	2 kW-ANSI	2 kW-DIN
DN	6"	150
D1	8.63"	219.1
L1	27.56"	700
L2	17.6"	447
L3	8.78"	223
L4	22.44"	570
L6	9.06"	230
LA	34.02"	864
kØ	9.5"	240
lØ	0.88"	22
b	0.94"	22
I.	ANSI 150 lbs compatible or DIN 2576	
II.	Cable length approx. 9 metres / 354"	
III.	Wall clearance at least 300 mm / 12"	
IV.	ANSI 150 lbs compatible or DIN 2576	

Drawings not true to scale.

(All dimensions in "mm"), unless otherwise indicated.

Type	3 kW-ANSI	3 kW-DIN
DN	8"	200
D1	12.75"	323.9
L1	31.5"	800
L2	21.54"	547
L3	10.75"	273
L4	26.38"	670
L6	11.02"	280
LA	41.89"	1064
kØ	11.75"	295
lØ	0.88"	22
b	0.94"	24
I.	ANSI 150 lbs compatible or DIN 2576	
II.	Cable length approx. 9 metres / 354"	
III.	Wall clearance at least 300 mm / 12"	
IV.	ANSI 150 lbs compatible or DIN 2576	

Drawings not true to scale.

(All dimensions in "mm"), unless otherwise indicated.

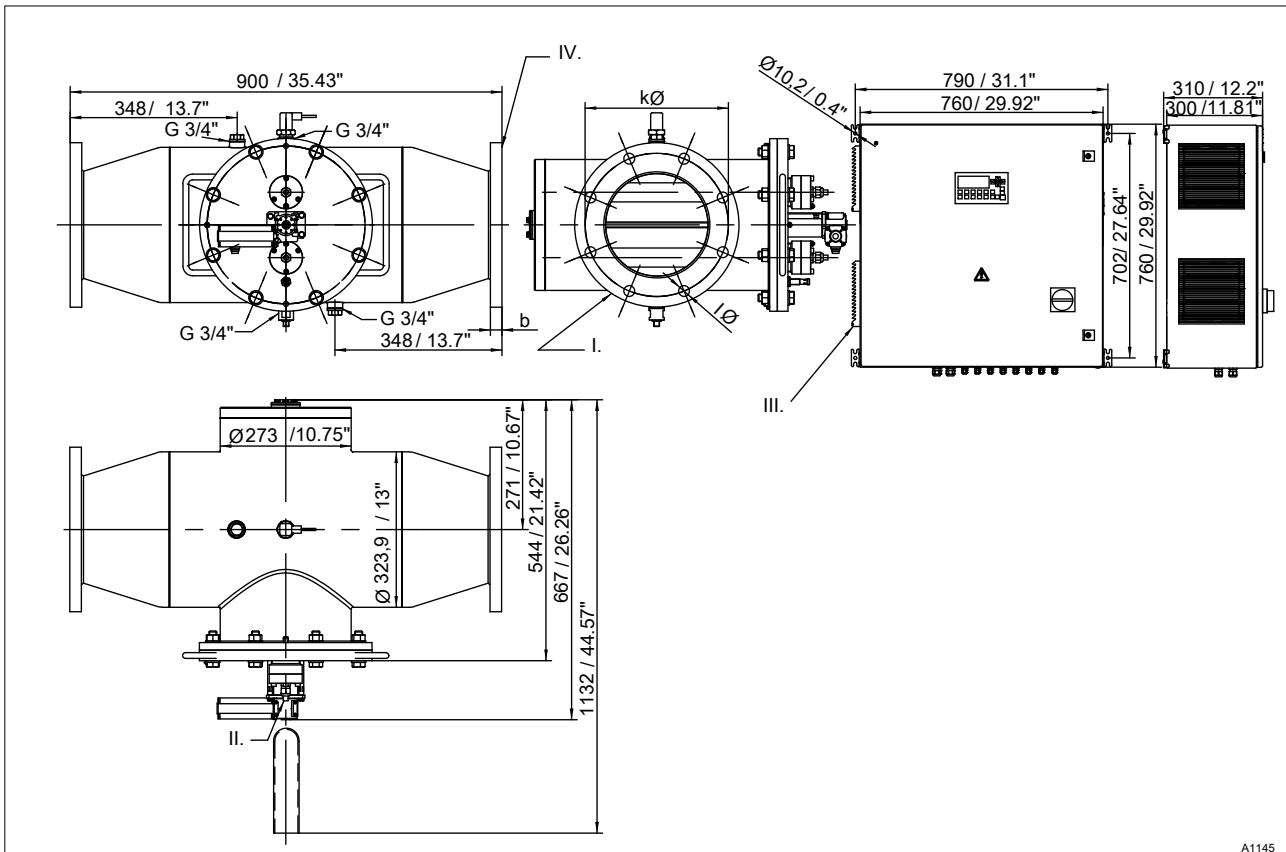

A1145

Fig. 98: Dimensions sheet for dual lamp systems

Type	2x2 kW-ANSI	2x2 kW-DIN
DN	8"	200
kØ	11.75"	295
lØ	0.88"	22
Number I	8	8
b	0.94"	24
I.	ANSI 150 lbs compatible or DIN 2576	
II.	Cable length approx. 9 metres / 354"	
III.	Wall clearance at least 300 mm / 12"	
IV.	ANSI 150 lbs compatible or DIN 2576	

Drawings not true to scale.

(All dimensions in "mm"), unless otherwise indicated.

Type	2x3 kW-ANSI	2x3 kW-DIN
DN	10"	250
kØ	14.25"	350
lØ	1"	25.4

Drawings not true to scale.

(All dimensions in "mm"), unless otherwise indicated.

Type	2x3 kW-ANSI	2x3 kW-DIN
Number I	12	12
b	1.02"	26
I.	ANSI 150 lbs compatible or DIN 2576	
II.	Cable length approx. 9 metres / 354"	
III.	Wall clearance at least 300 mm / 12"	
IV.	ANSI 150 lbs compatible or DIN 2576	

Drawings not true to scale.

(All dimensions in "mm"), unless otherwise indicated.

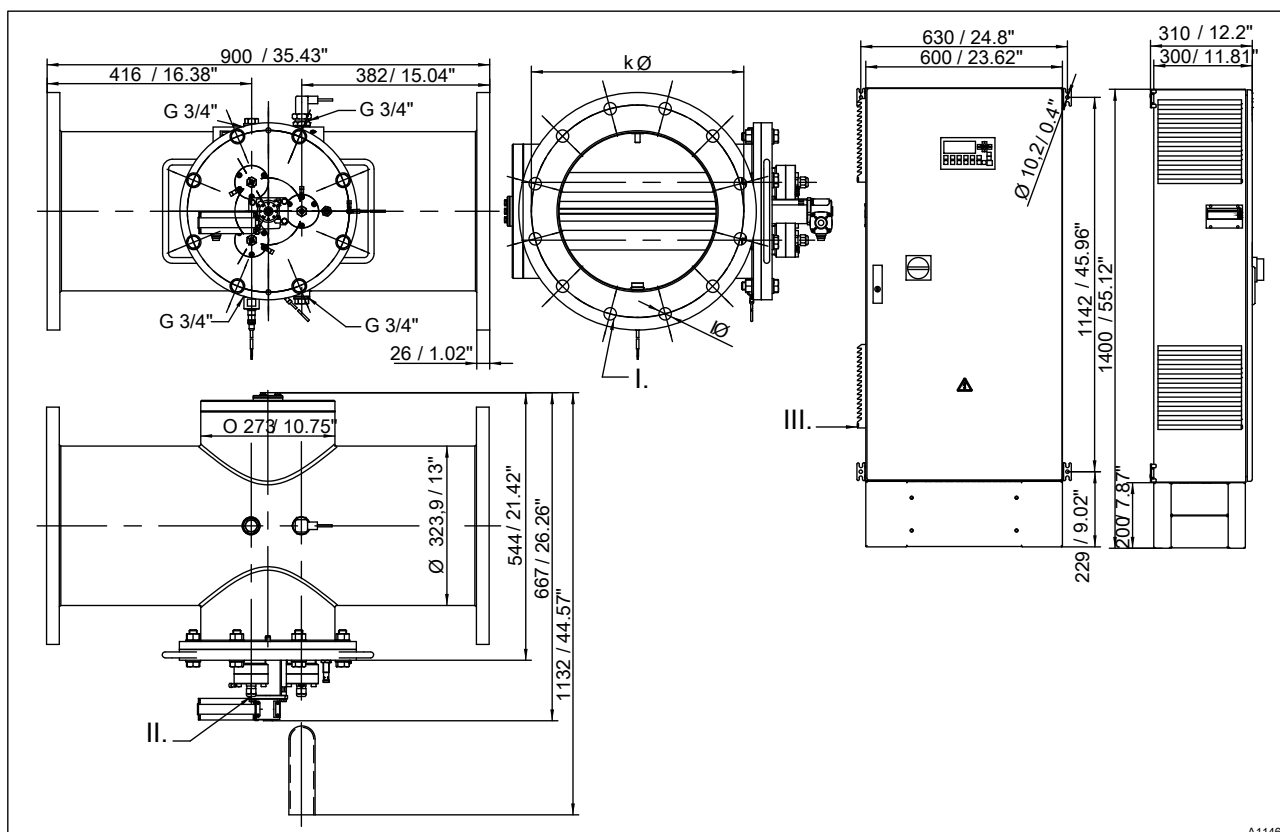

Fig. 99: Dimensions sheet for triple lamp systems

Type	3x3 kW-ANSI	3x3 kW-DIN
DN	12"	300
kØ	17"	400
IØ	1"	22
I.	ANSI 150 lbs compatible or DIN 2576	
II.	Cable length approx. 9 metres / 354"	
III.	Wall clearance at least 300 mm / 12"	

Drawings not true to scale.

(All dimensions in "mm"), unless otherwise indicated.

11.2 Electrical data

Type	Voltage		Frequency
1x1A	85...264 V AC / 1 phase		50/60 Hz
1x2A	85...264 V AC / 1 phase		50/60 Hz
1x3A	85...264 V AC / 3 phases	320...575 V AC / 3 phases	50/60 Hz
2x2A	85...264 V AC / 3 phases	320...575 V AC / 3 phases	50/60 Hz
2x3A	85...264 V AC / 3 phases	320...575 V AC / 3 phases	50/60 Hz
3x3A	85...264 V AC / 3 phases	320...575 V AC / 3 phases	50/60 Hz

* Observe the supplied system circuit diagram.

Appendix

No.	Description	Spare parts number	Replacement interval	No.
90	Spare parts kit UVA 1x1/1x2/1x3 kW	1042860	1 year	1
95	Bearing bush installation tool	1036907		1
96	Threaded sleeve installation tool	1037738		1
101	UV lamp protection tube, Ø40x2x315, 1 kW	1035218	2 ... 3 years	1
101	UV lamp protection tube, Ø40x2x415, 2 kW	1041723	2 ... 3 years	1
101	UV lamp protection tube, Ø40x2x515, 3 kW	1041485	2 ... 3 years	1
102	UV lamp UVA 1kW	1035179	8000 h	1
102	UV lamp UVA 2kW	1041450	8000 h	1
102	UV lamp UVA 3kW	1041451	8000 h	1
104	Mounting Ø 69x39.5 G2"	1035059		1
105	Retainer 48.5/38.7 x 3 PTFE white	1035074	as necessary	1
113	Temperature switch G 3/4	1035104	as necessary	1
114	Bearing ring Ø 52.4/41 x 12 PTFE	1035058	as necessary	1
115	Washer Ø69 x 20 - M 16 x 1.5	1035004	as necessary	1
117	Socket cap screw DIN 912 - M6 x 30 A2	791792		3
120	Locking screw DIN 910 G 3/4	1002753	as necessary	2
121	Complete cable clamp, Ø34.5 x 36	1035011	as necessary	1
122	Bearing plate	1041183		1
123	Cheese head screw DIN 7985 M4x25 A2	468607		2
124	Skintop threaded connector M16 x1.5, brass, nickel-plated	1035937		1
130	UV sensor A G 3/4 1.4539	1041449		1
140	Chamber cover complete, UVA, with motor wiper	1042066		1
141	O-ring 149.2 - 5.34 EPDM	1027463	after opening chamber	1
142	Hexagonal head screw, EN 24014, M16 x 65	1011337		4
143	Washer, DIN 125-1, A17 A4	1011507		8
144	Hexagonal nut, EN 24032, M16 A2	469046		4
145	Cable lug, RB5 2.5	704116		2
150	O-ring 40 - 5 EPDM	1023569	as necessary	2
153	O-ring/M 22.00 - 3.00 EPDM	1002175	as necessary	2
154	O-ring/M 25.00 - 2.00 EPDM	792872	as necessary	2
158	O-ring/M 16.00 - 3.00 EPDM	1004921	5 years	1
180	Cheese head screw DIN 7985 M5x12 A2	468624		3
181	Serrated washer, DIN 6797, A 5.3 A2	463009		3
182	Plain washer, DIN 433, 5.3 A2	466609		3

* = is part of the spare parts kit UVA 1x3 kW (part number 1042860)

No.	Description	Spare parts number	Replacement interval	No.
183	Hexagonal head screw, DIN 933, M6x16, A2	468210		3
304	Plain washer, DIN 125 A, 6.4 A2	462219		6
305	Distance pin, Ø10x82	1041833		3
316 *	X-ring 13.75 x 5.3 x 4.75 70 EPDM 281	1010384	1 year	1
318 *	Slip washer	1041199	1 year	1
320	Bearing cover complete UVA motor wiper	1037028	as necessary	1
327	Socket cap screw, DIN 912, M5x30, A2	468008		3
328	Socket cap screw, DIN 7984, M3x10, A2	1041829		4
340	Wiper rod complete, UVA, 1 kW, motor wiper	1041788		1
340	Wiper rod complete, UVA, 2 kW, motor wiper	1041789		1
340	Wiper rod complete, UVA, 3 kW, motor wiper	1041790		1
354	Flange plate, gear	1041830		1
356	Protective cover, UVA, Ø50x3.7x71	1041847		1
357	Coupling, TX1, series 10, D8	1041484		1
362 *	Slide bearing F 8x10x10 IGLIDUR®	1037033	1 year	1
363	Counter bearing spindle, UVA	1041827	5 years	1
364 *	Threaded sleeve TR 12 x 3 POM	1037070		1
365 *	Slide bearing	1037575		2
367	Magnetic sensor, MB60-12GM50-E2V1	1042118		1
368	Hexagonal nut, M12x1, PA black, DIN 439	1000075		1
510	EC motor, BG, 44x50SI, 24 V DC, with gear	1041452		1
530	Reed switch, flat	1042824	as necessary	1
654	Assembly, safety unit			
860	Face spanner for Ø 14 - 100 mm	409805	as necessary	1
880	Filter mat SK 3172.100 Filter for air outlet	791038	1/2 ... 1 year	2
900 *	Wiper element	1027879	1 year	1
901	Holding ring Ø 62 / 45 x 4 for UVR PTFE pure white	1028100	as necessary	1
--	Filter mat SK 3172.200 Filter for the fan	791039	1/2 ... 1 year	1

* = is part of the spare parts kit UVA 1x3 kW (part number 1042860)

No.	Description	Spare parts number	Replacement interval	No.
--	Lamp cable ÖLFLEX®, 2x2.5 mm ² 10 metres	1041533	as necessary	1
--	Shaft Ø14/Ø8 for the X-ring	1041758	as necessary	1

*** = is part of the spare parts kit UVA 1x3 kW (part number 1042860)**

12.2 Spare parts for 2x2 kW, 2x3 kW, 3x3 kW multiple lamp system

Tab. 13: Spare parts list for 2x2 kW, 2x3 kW, 3x3 kW multiple lamp system with automatic wiper

No.	Designation	Spare parts number	Replacement interval	No.
090	Spare parts kit UVA 3x3 kW	1044863	1 year	1
090	Spare parts kit UVA 2x2 kW, 2x3 kW	1044862	1 year	1
095	Bearing bush installation tool	1036907		1
096	Threaded sleeve installation tool	1037738		1
101	UV lamp protection tube Ø40x2x515 mm, 2 kW / 3 kW	1041485	2 ... 3 years	1
102	UV lamp 2 kW	1041450	max. 8000 h	2
102	UV lamp 3 kW	1041451	max. 8000 h	2 ... 3
104	UV lamp protection tube bracket	1035059	as necessary	2 ... 3
105	Retainer 48.5/38.7 x 3 PTFE white	1035074	as necessary	2 ... 3
113	Temperature switch G 3/4	1035104	as necessary	1
114	Bearing ring Ø52.4/41 x 12 PTFE	1035058	as necessary	2 ... 3
115	Washer Ø69 x 20; M16 x 1.5	1035004	as necessary	2 ... 3
120	Locking screw DIN 910 G 3/4	1002753	as necessary	2
121	Complete cable clamp, Ø34; 5 x 36	1035011	as necessary	2 ... 3
122	Bearing plate	1042183		1
130	UV sensor A G 3/4 1.4539	1041449	as necessary	1
131	UV sensor connection cable 10 m	1028063	as necessary	1
141	O-ring 149.2 - 5.34 EPDM	1027463	after opening the chamber	1
150	O-ring 40 - 5 EPDM	1023569	as necessary	4 ... 6
153	O-ring/M 22.00 - 3.00 EPDM	1002175	as necessary	3
154	O-ring/M 25.00 - 2.00 EPDM	792872	as necessary	2
158	O-ring/M 16.00 - 3.00 EPDM	1004921	5 years	1
316 *	X-ring 13; 75 x 5; 3 x 4; 75 70 EPDM 28	1010384	1 year	1
318 *	Slip washer	1041199	1 year	1
320	Bearing cover complete with UVA motor	1037028	as necessary	1
340	Wiper rod complete for 2x2 kW, 2x3 kW	1037485	as necessary	1
340	Wiper rod complete for 3x3 kW	1037522	as necessary	1
362 *	Slide bearing F 8x10x10 IGLIDUR®	1037033	1 year	1
363	Counter bearing spindle, UVA	1041828	5 years	1
364 *	Threaded sleeve, Tr 12 x 3 POM	1037070	1 year	1

* = forms part of the spare parts kit UVS 3x3 kW (1044863) or spare parts kit UVS 2x2 kW, 2x3 kW (1044862)

No.	Designation	Spare parts number	Replacement interval	No.
365 *	Slide bearing Ø16, 8 x 15, IGLIDUR®	1037575	1 year	2
590	Reed switch, flat	1042824	as necessary	2 ... 3
860	Face spanner for Ø 14 ... 100 mm	409805	as necessary	1
880	Filter mat SK 3172.100 Filter for air outlet	791038	1/2 ... 1 year	2
900 *	Wiper element	1027879	1 year	2 ... 3
901	Retaining ring Ø62/45 x 4	1028100	as necessary	2 ... 3
--	Filter mat SK 3172.200 Filter for the fan	791039	1/2 ... 1 year	1
--	Filter mat SK for the small fan, for 3x3 kW only	791037	1/2 ... 1 year	1
--	Lamp cable ÖLFLEX®, 2x2.5 mm ² , 10 metres	1035504	as necessary	2 ... 3
--	Shaft Ø14/Ø8 for the X-ring	1041758	as necessary	1
* = forms part of the spare parts kit UVS 3x3 kW (1044863) or spare parts kit UVS 2x2 kW, 2x3 kW (1044862)				

12.4 Disposal of used parts

- **User qualification:** instructed user, see [Chapter 3.2 'User qualification'](#) on page 12



NOTICE!

Regulations governing the disposal of used parts

- Note the national regulations and legal standards that currently apply in your country

The manufacturer will take back decontaminated used devices providing they are covered by adequate postage.

Decontaminate the device before returning it for repair. To do so, remove all traces of hazardous substances. Refer to the Material Safety Data Sheet for your feed chemical.

A current Declaration of Decontamination is available to download on the ProMinent website.

Sign indicating EU collection system



In accordance with the European Directive 2012/19/EU on waste electrical and electronic equipment, this device features the symbol showing a waste bin with a line through it. The device must not be disposed of along with domestic waste. To return the device, use the return and collection systems available and observe the local legal requirements.

12.5 Declaration of Conformity

In accordance with the DIRECTIVE 2006/42/EC OF THE EUROPEAN PARLIAMENT AND OF THE COUNCIL, Appendix I, BASIC HEALTH AND SAFETY REQUIREMENTS, section 1.7.4.2. C.

We,

- ProMinent GmbH
- Im Schuhmachergewann 5 - 11
- D - 69123 Heidelberg, Germany,

hereby declare that the product specified in the following, complies with the relevant basic health and safety requirements of the EU Directive, on the basis of its functional concept and design and in the version distributed by us. Any modification to the product not approved by us will invalidate this declaration.

Tab. 14: Extract from the EU Declaration of Conformity for Devices with Motor Wipers

Designation of the product:	Dulcodes UV disinfection system
Product type:	UVCb - - - - - X - - - - - X = 4, 5
Serial number:	see nameplate on the unit
Relevant EU directives:	EU Machinery Directive (2006/42/EC) EU EMC Directive (2014/30/EU) EU Pressure Equipment Directive (2014/68/EU) Compliance with the protection targets of the Low Voltage Directive 2014/35/EU according to Appendix I, No. 1.5.1 of the Machinery Directive 2006/42/EC EU RoHS Directive (2011/65/EU)
Harmonised standards applied, in particular:	EN 12100:2010 EN 60204-1:2009 EN 60335-1:2014 EN 60529:2014 EN 61000-3-2:2015 EN 61000-6-2:2006 EN 61000-6-3:2012 (UVCbXXX..., XXX ≠ 04O-06O,) N 61000-6-4:2011 (UVCbXXX..., XXX = 04O-06O)
Applied national standards and other technical specifications in particular:	AD 2000
Date:	Heidelberg, 20.04.2016

The EC Declaration of Conformity is available to download on our homepage.

13 Index

A	
Action, step by step	2
Applied harmonised standards	113
C	
Calibrating the UV sensor	91
Calibration	91
Chloramines	5
Control cabinet	104
Control, version	19
Cooling down mode	18
D	
Data sheet	5
Declaration of Conformity	113
Designation of the product	113
Disinfection	5
Disinfection support	5
Display background lighting	94
E	
Emergency	14
Error messages	95
EU Declaration of Conformity	113
F	
Fingerprints on the UV lamp	70
Function and effect of the operating device control keys	7
G	
General information about wiper control	34
General non-discriminatory approach	2
I	
Inputs	104
Instructions: Replacing the wearing parts	69
K	
KP300: Entering numbers and characters	8
KP300: Limit value checking with numerical values	9
KP300: Menu operation	8
L	
Links to elements or sections of these instructions or other applicable documents	2
Load	104
M	
Maintenance work: Dismantling	70
Manually triggering a wiper cycle	17
Maximum temperature	17
More symbols	2
N	
Non-discriminatory approach	2
Normal operation	16
O	
Operating error	5
Operating mode: Control, external	17
Operating mode: Control, internal	17
Operating Parameters	14
Operating pressure	99
Operating temperature	16
Outputs	104
Overheating	14
P	
Performance data	98
Permissible ambient conditions during operation	15
Permissible ambient conditions during storage	15
Permissible operating temperatures	99
Q	
Question: Are shut-off valves and rinse valves not part of the scope of supply?	16
Question: How are the function keys used?	6
Question: How can I adjust the lamp control? ...	40
Question: How can I input data on the control? ...	7
Question: How can I start the wiper manually? ...	17
Question: How high is the maximum operating pressure?	99
Question: How is the operating concept configured?	6
Question: How is the UV sensor calibrated?	91
Question: How loud is the UV system?	99
Question: What does the UV sensor monitor in normal mode?	17
Question: What error messages are displayed if faults occur?	95
Question: What is a typical installation layout for a UV system?	16
Question: What is the significance of the display lighting colours?	94

Question: What warning messages are displayed when operating the device? 97

Question: Which wearing parts do I have to replace? 69

R

Regular wiping 17

Relevant EC directives 113

S

Serial number 113

Sound pressure level 99

Spare parts kit 69

Standard signal output 104

T

The function keys F1 ... F10 6

U

Ultraviolet radiation 14

Use 5

User qualification 12

UV lamp switch off 18

UV output 17

UV transmission 13

W

Warm-up time 16

Warning information 10

Warning messages 97

water temp 17



ProMinent GmbH
Im Schuhmachergewann 5 - 11
69123 Heidelberg, Germany
Telephone: +49 6221 842-0
Fax: +49 6221 842-419
Email: info@prominent.com
Internet: www.prominent.com

985175, 7, en_GB