



CITY OF KELLER



STEFANI SHULTZ
COMMERCIAL SALES

MOBILE: 469-286-8128
STEFANI@COMM-FIT.COM



STEFANI SHULTZ

COMMERCIAL SALES

CONTACT DETAILS:

MOBILE: 469-286-8128
STEFANI@COMM-FIT.COM

QUICK FACTS:

EDUCATION: Texas State
University, Bachelors of
Science - Fashion

TYPICAL WORKOUT: Orange
Theory, Yoga, Running, Riding
Bikes, Strength Training

HOBBIES: Painting, Gardening,
and Fashion



WHY COMM-FIT?

Comm-Fit brings 250 years of combined knowledge and experience in the commercial fitness industry. We provide turnkey solutions to fitness facilities, including sales, service and maintenance of fitness equipment, sales and installation of flooring, and sales of disinfecting products and services.

Comm-Fit is the Leader in Innovative Fitness Facility Solutions

Thank you for giving Comm-Fit the opportunity to serve your fitness needs. I can assist you with everything from design, to equipment choice to flooring and facility disinfecting. I look forward to continue to be of service in any way I can for years to come!

In Health,

Stefani Shultz





4651 Sunbelt Dr., Addison, TX 75001

Phone: 469-286-8128

Fax: 972-620-7798

Number: AAAQ21199-02

Date: Apr 29, 2021

QUOTES ARE VALID FOR 30 DAYS

Bill To:
<p>Keller Senior Activity Center Kyle Cooper 660 Johnson Road Keller, TX 76244 United States of America</p> <p>Phone (817) 743-4052 Fax</p>

Ship To:
<p>Keller Senior Activity Center Kyle Cooper 660 Johnson Road Keller, TX 76244 United States of America</p> <p>Phone (817) 743-4052 Fax</p>

Salesperson		P.O. Number	Installer	Terms		
Stefani			Comm-Fit Deliver	BUYBOARD #583-19		
Line	Qty	Item Number	Description	MSRP	Unit Price	Ext. Price
1	3	CRTL-ALLXX-01	CYBEX R SERIES 50L TREADMILL	\$8,200.00	\$5,740.00	\$17,220.00
2	3	C50LT-XWXXX-01	CYBEX R SERIES 50L TREADMILL CONSOLE, LED, WIRELESS	\$0.00	\$0.00	\$0.00
3	2	CRRL-ALLXX-01	CYBEX R SERIES 50L RECUMBENT BIKE	\$4,040.00	\$2,828.00	\$5,656.00
4	2	C50LB-XWXXX-01	CYBEX R SERIES 50L BIKE CONSOLE, LED, WIRELESS	\$0.00	\$0.00	\$0.00
5	2	CRATF-ALLXX-P	CYBEX R SERIES TOTAL BODY ARC TRAINER 50L (BASE)	\$8,240.00	\$6,180.00	\$12,360.00
6	2	C50LA-XWXXX-01	CYBEX R SERIES 50L ARC CONSOLE, LED, WIRELESS	\$0.00	\$0.00	\$0.00
7	7	CR-WARRANTY	CYBEX R-SERIES WARRANTY 3/3 B2B	\$600.00	\$450.00	\$3,150.00
8	1	21400	PRESTIGE TOTAL ACCESS STRENGTH (IFI ACCREDITED) - WITH STANDARD WEIGHT STACK CHEST PRESS	\$5,179.00	\$4,143.20	\$4,143.20
9	1	21410	PRESTIGE TOTAL ACCESS STRENGTH (IFI ACCREDITED) - WITH STANDARD WEIGHT STACK OVERHEAD PRESS	\$5,071.00	\$4,056.80	\$4,056.80
10	1	21451	PRESTIGE TOTAL ACCESS STRENGTH (IFI ACCREDITED) - WITH STANDARD WEIGHT STACK LEG EXTENSION W/ START RLD	\$5,179.00	\$4,143.20	\$4,143.20
11	1	21461	PRESTIGE TOTAL ACCESS STRENGTH (IFI ACCREDITED) - WITH STANDARD WEIGHT STACK SEATED LEG CURL W/ START RLD	\$5,179.00	\$4,143.20	\$4,143.20

Continued On Next Page ...

COMM-FIT INSTALLATION REQUIREMENTS: STANDARD LEAD TIMES APPLY. WE ARE CURRENTLY EXPERIENCING LONGER THAN NORMAL LEAD TIMES. EQUIPMENT SHIPMENTS MAY TAKE UP TO 10-14 WEEKS. CLIENT IS RESPONSIBLE FOR ENSURING JOB SITE IS CLEAN & READY FOR INSTALL. ELECTRICAL REQUIREMENTS MUST BE MET & ON AT TIME OF INSTALL. INSTALLATION CONFIRMED 14 DAYS PRIOR TO DELIVERY. ADDITIONAL FEES WILL APPLY FOR STORAGE, TRIP FEES & CHANGES AFTER CONFIRMATION. CONSULT YOUR SALES REPRESENTATIVE FOR DETAILED PRODUCT REQUIREMENTS.

TERMS: 50% DEPOSIT, BALANCE DUE BY DELIVERY OR PURCHASE ORDER. CUSTOM ORDERS & ORDERS BELOW \$5,000.00 REQUIRE PREPAYMENT. CREDIT CARD PAYMENTS SUBJECT TO A 3.5% TRANSACTION FEE. CANCELLATIONS SUBJECT TO 25% RESTOCKING FEE (100% FOR CUSTOM ORDERS). ORDER SUBJECT TO SALES TAX (IF APPLICABLE).

Line	Qty	Item Number	Description	MSRP	Unit Price	Ext. Price
12	1	21530	PRESTIGE TOTAL ACCESS STRENGTH (IFI ACCREDITED) - WITH STANDARD WEIGHT STACK LAT PULL	\$5,179.00	\$4,143.20	\$4,143.20
13	1	18000	FT-325 FUNCTIONAL TRAINER	\$4,855.00	\$4,126.75	\$4,126.75
14	1	18000-006	5 LB. DROP-ON INCREMENT WEIGHT FOR FUNCTIONAL TRAINING SYSTEMS	\$55.00	\$46.75	\$46.75
15	2	16001	CYBEX ADJUSTABLE 10 DEG TO 80 DEG BENCH	\$967.00	\$773.00	\$1,546.00
16	1	PRO1031-INT	SCIFIT PRO1000 UPPER BODY - ADJUSTABLE CRANKS - PREMIUM SEAT	\$5,300.00	\$3,975.00	\$3,975.00
17	1	SD-005-050R	TROY 5-50 LB RUBBER ENCASED DUMBBELLS (SET)	\$874.50	\$874.50	\$874.50
18	2	SD-003R	3 LB 8-SIDED RUBBER ENCASED DUMBBELL	\$6.36	\$4.77	\$9.54
19	2	SD-008R	8 LB 8-SIDED RUBBER ENCASED DUMBBELL	\$18.00	\$13.50	\$27.00
20	2	SD-012R	12 LB 8-SIDED RUBBER ENCASED DUMBBELL	\$26.00	\$19.50	\$39.00
21	1	GTDR-3	HORIZONTAL 3 TIER SHELF RACK. WILL STORE 15 PAIRS OF DUMBBELLS, 5LB-75LBS.	\$695.00	\$521.25	\$521.25
22	1	RCK-VERSA2	LOADED RACK W/ACC-55, 65 & 75; MEDBALL 6/8/10/12/15/20; ACC-EML(MATX4); RKETL 5/8/10/12/15/20/25/30	\$1,755.50	\$1,316.63	\$1,316.63
23	1	FREIGHT	FREIGHT AND PROCESSING	\$0.00	\$6,077.00	\$6,077.00
24	1	DEL	INSTALLATION AND DELIVERY	\$0.00	\$4,916.00	\$4,916.00
25	1	PMA -1YR	PREVENTATIVE MAINTENANCE SERVICE - 1 YEAR FREE (2 VISITS)	\$0.00	\$0.00	\$0.00
26			BUYBOARD #583-19			

SubTotal	\$82,491.02
Tax % 0.0000	\$0.00
Total	\$82,491.02

Signature _____ Date _____

Please sign and email to stefani@comm-fit.com or fax back to 972-620-7798.

Check Number:
Date Received:

Deposit Amount	\$0.00
Amount Due	\$82,491.02

COMM-FIT INSTALLATION REQUIREMENTS: STANDARD LEAD TIMES APPLY. WE ARE CURRENTLY EXPERIENCING LONGER THAN NORMAL LEAD TIMES. EQUIPMENT SHIPMENTS MAY TAKE UP TO 10-14 WEEKS. CLIENT IS RESPONSIBLE FOR ENSURING JOB SITE IS CLEAN & READY FOR INSTALL. ELECTRICAL REQUIREMENTS MUST BE MET & ON AT TIME OF INSTALL. INSTALLATION CONFIRMED 14 DAYS PRIOR TO DELIVERY. ADDITIONAL FEES WILL APPLY FOR STORAGE, TRIP FEES & CHANGES AFTER CONFIRMATION. CONSULT YOUR SALES REPRESENTATIVE FOR DETAILED PRODUCT REQUIREMENTS.

TERMS: 50% DEPOSIT, BALANCE DUE BY DELIVERY OR PURCHASE ORDER. CUSTOM ORDERS & ORDERS BELOW \$5,000.00 REQUIRE PREPAYMENT. CREDIT CARD PAYMENTS SUBJECT TO A 3.5% TRANSACTION FEE. CANCELLATIONS SUBJECT TO 25% RESTOCKING FEE (100% FOR CUSTOM ORDERS). ORDER SUBJECT TO SALES TAX (IF APPLICABLE).

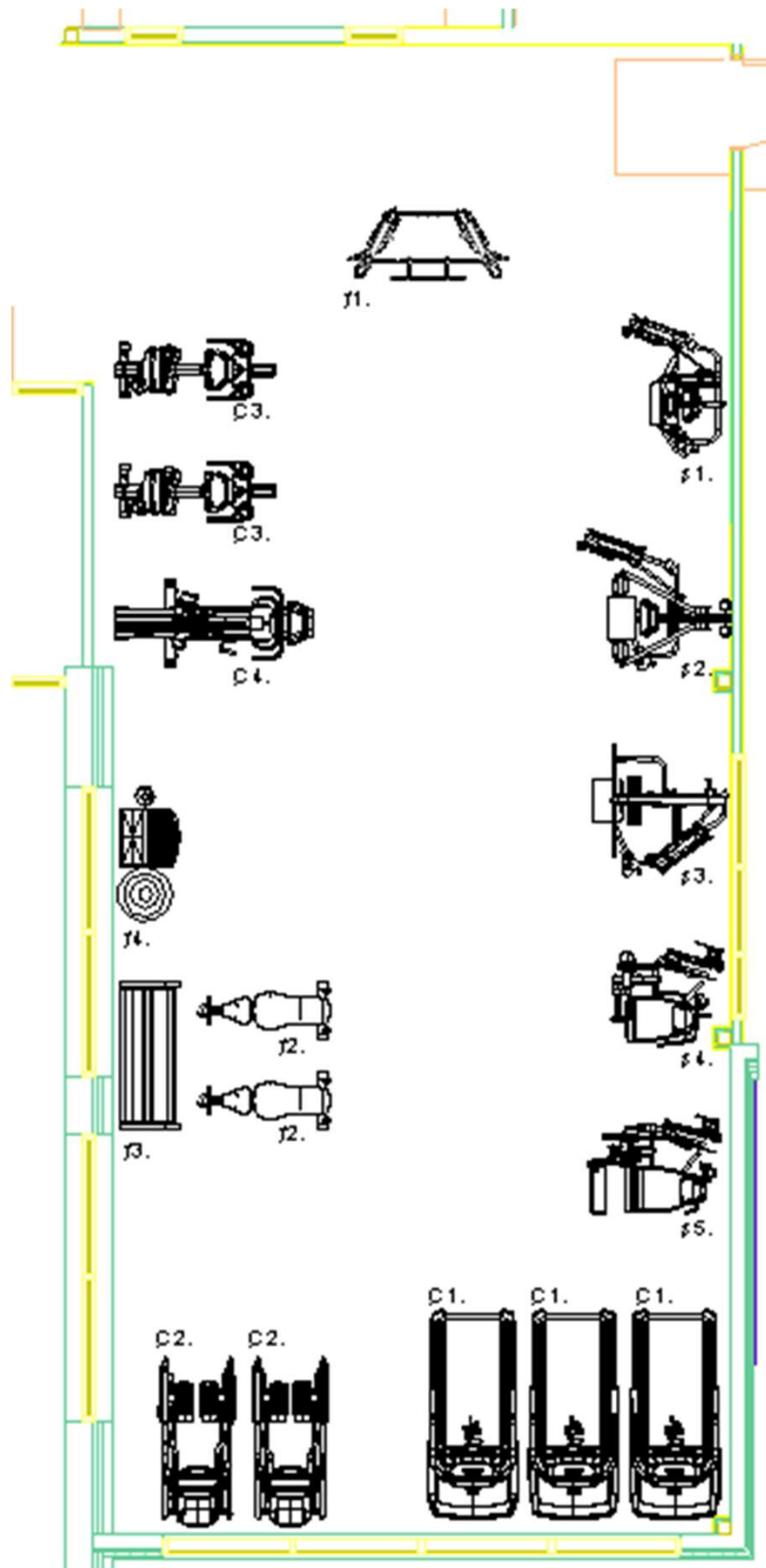

Clear Ceiling Height Minimum: 10ft

EQUIPMENT LEGEND

Cardio

- c1. Treadmill
- c2. Elliptical
- c3. Recumbent
- c4. Ube

Free Weights / Functional

- f1. Dual Adjustable Pulley
- f2. Adjustable Bench
- f3. Dumbbell Rack
- f4. Smart Rack

Selectorized

- s1. Chest Press
- s2. Overhead Press
- s3. Lat Pull
- s4. Leg Extension
- s5. Leg Curl

APPROXIMATION OF FLOOR AREA

Floor plan measurements are approximate and are for illustrative purposes only. Information provided to COMM-FIT by the Client or its representatives has been used for design and layout for this project. These layouts should not be used for construction and any dimensions, colors or textures used in the layouts should be verified by the facility or their contractor. These layout should not be altered from their original presentation without agreement between COMM-FIT and the Client, facility owner or representative.

Client initial and date: _____

ADA SPACING GUIDELINES

At least one of each type of exercise equipment must have clear floor space of 30" x 48" and a slope of 2%.

ASTM GUIDELINES

The minimum spacing recommendations below are based on a combination of the ASTM (U.S.) voluntary standards and EN (European) regulations as of October 1, 2012, for access, passage around, and emergency dismount:

Treadmills: A minimum of 0.5 m (19.7 in.) on each side of the treadmill and 2 m (78 in.) behind the machine.

Cardio Other Than Treadmills: A minimum of 0.5 m (19.7 in.) on at least one side, and 0.5 m (19.7 in.) behind or in front of the machine.

MANUFACTURERS SPACING GUIDELINES

The manufacturer suggests 78" of clearance behind the treadmill.

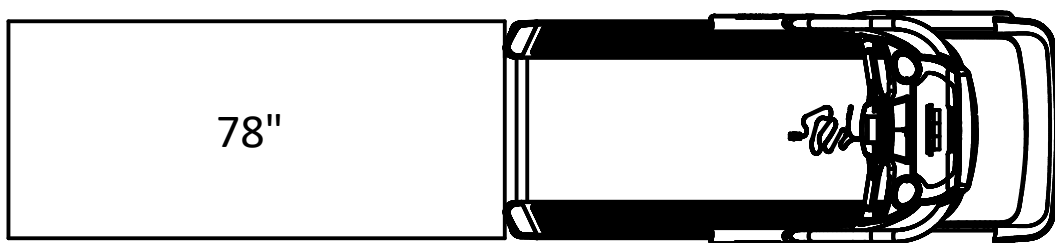



R Series R Series Treadmill



Interval Training Zone allows exercisers to easily change speed at the touch of a button.



The optional Service Wheel allows for the treadmill to be moved easily during equipment rotation and routine maintenance.

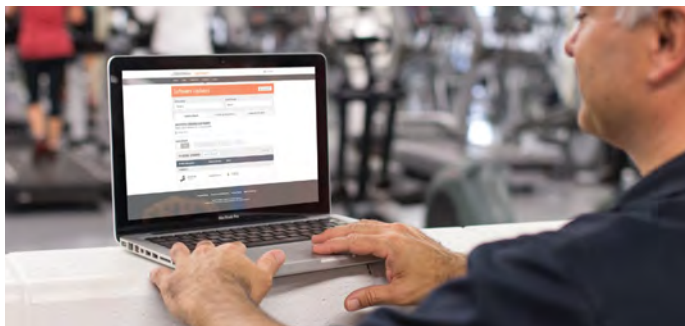

FACILITY MANAGEMENT

Optional internet connection provides detailed equipment use information, exerciser insights and preventive maintenance alerts. Connection also enables remote equipment monitoring, which allows our knowledgeable technicians to alert you in the rare case of a problem, often before you know one exists.



21" x 60" (53 x 152 cm)
running surface.

9.5" (24 cm)
step-up height.

IS4 Intelligent Suspension System matches the mechanics of running. The deck is soft upon landing, firm in the middle and rigid at toe-off.

SPECIFICATIONS

Product Name	R Series Treadmill
Dimensions (L x W x H)	83" x 36" x 62.5" (210 x 91.5 x 159 cm)
Speed	0.5 - 14 mph (0.8 - 23 kph)
Incline Levels	0% - 15%
Belt (L x W)	60" x 22" (152 x 56 cm)
Running Area (L x W)	60" x 21" (152 x 52.5 cm)
Max User Weight	400 lbs (181 kg)
Drive	4.0hp (8.0hp Peak) AC Motor
Power	120V, 20A or 230V, 10A (varies by country) outlet with dedicated line, neutral, ground wires and dedicated circuit breaker Japan: 100V, 20A or 200V, 10A outlet with dedicated line, neutral, ground wires and dedicated circuit breaker.
Entertainment Options	MYE and attachable TV option for 50L Console
Charging	USB port for software updates & device charging
Compliance	TUV CUE certificate to UL1647, CSA C22.2-60335-1, IEC60335-1; EN ISO 20957-1, EN 957-6, FCC Class A (domestic), CE General Product Safety, Low Voltage, EMC and RoHS Directives, ASTM
Heart Rate Monitoring	Contact Ergo Handles
Safety	Emergency Stop System and Safety Stop Pull Cord
Color	Platinum Sparkle
Warranty	Mechanical: 1 year
	Labor: 1 year
	Cosmetics: 6 months Frame and motor: 7 years



R Series Arc Trainer



LOWER BODY OPTION

Stationary arms allow for exercisers to concentrate on powerful lower-body workouts.

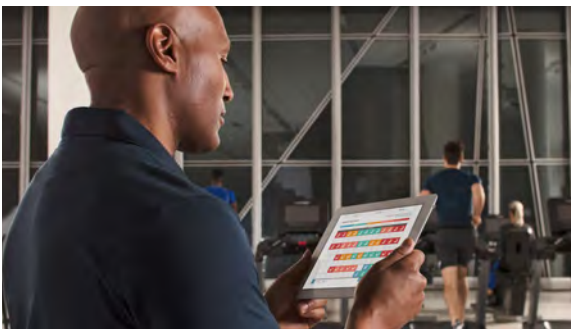

FACILITY MANAGEMENT

Standard internet connection provides detailed equipment use information, exerciser insights and preventive maintenance alerts. Connection also enables remote equipment monitoring, which allows our knowledgeable technicians to alert you in the rare case of a problem, often before you know one exists.



SPECIFICATIONS

Product Name	R Series Arc Trainer
Dimensions (L x W x H)	81" x 32" x 57" (205 x 82 x 145 cm)
Max User Weight	400 lbs (181 kg)
Power	120V, 20A or 230V, 10A (varies by country) outlet with dedicated line, neutral, ground wires and dedicated circuit breaker
Console Options	70T Console: Touchscreen with integrated TV 50L Console: Intuitive console with bright LED display
Base Options	Lower body with stationary arms Upper body with moving arms
Heart Rate Monitoring	Contact handles
Compliance	TUV CUE certificate to UL1647, CSA C22.2-60335-1, IEC60335-1; EN ISO 20957-1, EN 957-6, FCC Class A (domestic), CE General Product Safety, Low Voltage, EMC and RoHS Directives, ASTM
Color	Platinum Sparkle
Warranty	Mechanical: 2 years Labor: 1 year Cosmetics: 6 months Frame and motor: 7 years



R Series

R Series Recumbent Bike



Wraparound seat adjustment for quick and easy positioning.



Easily adjustable pedal straps.

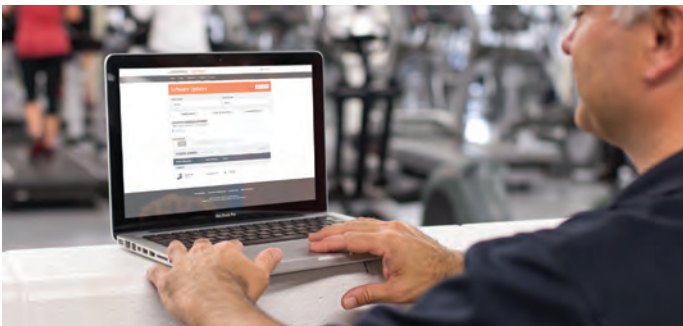

FACILITY MANAGEMENT

Easily connect to the LFconnect.com for detailed equipment use information, exerciser insights and preventive maintenance alerts. Connection also enables LFconnect Protect remote equipment monitoring, which allows our knowledgeable technicians to alert you in the rare case of a problem, often before you know one exists.



SPECIFICATIONS

Product Name	R Series Recumbent
Dimensions (L x W x H)	66" x 26.5" x 45.2" (167 x 67.3 x 115 cm)
Power Range	20-900+ Watts
Resistance Levels	25
Drive Type	Generator drive system with 8-ribbed poly-V belt for smooth, quiet operation with low maintenance
Max User Weight	400 lbs (181 kg)
Power	Self Powered 12V (50L console only) Auto Start: Brings power to console when user begins pedaling The base is configured for both 120V/15A/60Hz and 230V/10A/50Hz
Entertainment Options	MYE and attachable TV option for 50L console
Heart Rate Monitoring	Contact grips on handlebars
Compliance	TUV CUE certificate to IEC60335-1; CSA C22.2-60335-1, EN ISO 20957-1, EN ISO 20957-5 (bikes), FCC Class B (domestic), CE General Product Safety, Low Voltage, EMC and RoHS Directives, ASTM
Color	Platinum Sparkle
Warranty	Mechanical/electrical: 2 years Labor: 1 year Cosmetics: 6 months

R Series

50L Console

A simplified experience allows exercisers to get started with their cardio workouts quickly and efficiently.

FEATURES

- Bright LED display is easy to read
- Six preset workouts and a quick start feature
- Large buttons for easy adjustments on the fly
- Preset resistance buttons for easy selection during interval training (Arc Trainer and Bikes only)
- QR code enables workout tracking through the LFconnect app

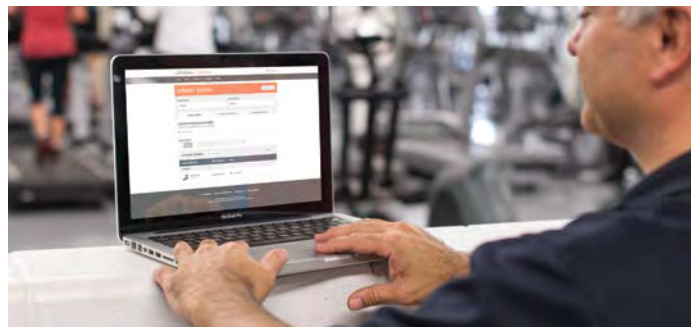

FACILITY MANAGEMENT

Easily connect to LFconnect.com for detailed equipment use information, exerciser insights and preventive maintenance alerts. Connection also enables LFconnect Protect remote equipment monitoring, which allows our knowledgeable technicians to alert you in the rare case of a problem, often before you know one exists.



SPECIFICATIONS

Display	LED
Navigation	Large membrane buttons
Readouts	Treadmill: Speed, Time, Distance, Heart Rate, Calories, Incline, Pace
	Bikes: Speed, Time, Distance, Heart Rate, Calories, Watts, Resistance, RPM
	Arc Trainer: Incline, Time, Distance, Heart Rate, Calories, Watts, Resistance, SPM
Workouts	Treadmill: Speed Bump, Rollers, Peaks, Hill Interval, Rolling Hills, Interval Plus
	Bikes: Calorie Burner, Advanced Burner, Peaks, Ramps, Bursts, Waves
	Arc Trainer: Quick Start, Hill Climb, High Intensity Interval, Elevated Interval, Endurance, Power Blast, Interval Burn
Languages	Universal
Wireless Connectivity	Yes
USB Port	For software updates and device charging
Asset Management	Through LFconnect.com (with internet connection)
Attachable TV	Optional

Prestige Total Access Overhead Press

The 12-piece Total Access line not only meets, but exceeds Inclusive Fitness Initiative (IFI) standards. Providing fitness facilities with a complete cardio and strength solution that accommodates exercisers of all abilities to train in a safe, controlled environment.

FEATURES

- **Swing away seat with locking plunger adjustment:** Allows easy access for wheelchair users and one-handed seat adjustment for users with limited mobility.
- **Choice of upper and lower handle positions:** Caters to wheelchair users, shorter users and those with reduced balance.
- **Counterbalanced input arm:** With 5.5 lb (2.5 kg) start weight allows all users with low starting resistance for single arm (unilateral) use.

USER AMENITIES

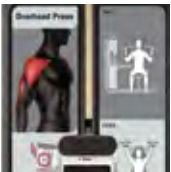

- **Placards:** Large type instructions and easy-to-understand graphics guide proper set-up, movement, and muscles trained.



- **Smartphone/tablet holder:** Your mobile device is safe and secure with our adjustable clip, designed for all smartphones and tablets. Simply clip in and go.



- **Water bottle/towel holder:** Keep your water and towel within arm's reach with our convenient water bottle and towel holder, standard on every Prestige machine.



- **Twist select incremental weight system:** Allows ease of weight selection from seated exercise position.



SPECIFICATIONS

Product Number	21410
Dimensions L x W x H	61" x 59" x 64" (156 cm x 150 cm x 163 cm)
Standard Stack	165 lb (75 kg)
Heavy Stack	205 lb (93 kg)
Standard Weight	450 lb (205 kg)
Heavy Weight	490 lb (223 kg)
Color	Available in 15 frame colors or a virtually unlimited variety of custom colors, 33 upholstery colors and 4 enclosure styles



Prestige Total Access

Row/Rear Delt

The 12-piece Total Access line not only meets, but exceeds Inclusive Fitness Initiative (IFI) standards. Providing fitness facilities with a complete cardio and strength solution that accommodates exercisers of all abilities to train in a safe, controlled environment.

FEATURES

- **Locking plunger adjustment on swing away seat:** Allows easy access for wheelchair users and one-handed seat adjustment for users with limited mobility.
- **Choice of upper and lower handle positions:** Caters to wheelchair users who cannot adjust seat height, shorter users and those with reduced balance, who can then maintain full foot contact with the floor.
- **Eight position reversible chest pad:** Ensures a full range of movement is achieved by both tall and short users.



USER AMENITIES



- **Placards:** Large type instructions and easy-to-understand graphics guide proper set-up, movement, and muscles trained.



- **Smartphone/tablet holder:** Your mobile device is safe and secure with our adjustable clip, designed for all smartphones and tablets. Simply clip in and go.



- **Water bottle/towel holder:** Keep your water and towel within arm's reach with our convenient water bottle and towel holder, standard on every Prestige machine.



- **Twist select incremental weight system:** Allows ease of weight selection from seated exercise position.

SPECIFICATIONS

Product Number	21430
Dimensions L x W x H	51" x 46" x 76" (130 cm x 117 cm x 193 cm)
Standard Stack	245 lb (111 kg)
Heavy Stack	305 lb (138 kg)
Standard Weight	460 lb (209 kg)
Heavy Weight	520 lb (236 kg)
Color	Available in 15 frame colors or a virtually unlimited variety of custom colors, 33 upholstery colors and 4 enclosure styles

Prestige Total Access Leg Extension

The 12-piece Total Access line not only meets, but exceeds Inclusive Fitness Initiative (IFI) standards. Providing fitness facilities with a complete cardio and strength solution that accommodates exercisers of all abilities to train in a safe, controlled environment.

FEATURES

- **Sliding adjustment for shin pad length:** Easily adjusts with one hand.
- **Spring loaded seat back adjustment lever:** Can be adjusted either from on or off the equipment. The push down lever is easy to operate for users with limited grip.
- **Raised numbers and large font on Range Limited Device:** Makes start position easier to adjust and identify for visually impaired and older users.
- **Optional step:** Not included.

USER AMENITIES

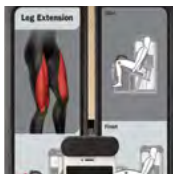

- **Placards:** Large type instructions and easy-to-understand graphics guide proper set-up, movement, and muscles trained.

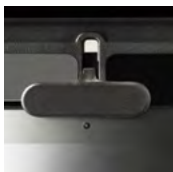

- **Smartphone/tablet holder:** Your mobile device is safe and secure with our adjustable clip, designed for all smartphones and tablets. Simply clip in and go.



- **Water bottle/towel holder:** Keep your water and towel within arm's reach with our convenient water bottle and towel holder, standard on every Prestige machine.

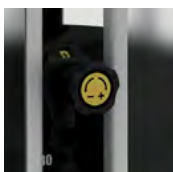

- **Twist select incremental weight system:** Allows ease of weight selection from seated exercise position.



SPECIFICATIONS

Product Number	21451
Dimensions L x W x H	49" x 41" x 58" (124 cm x 104 cm x 147 cm)
Standard Stack	245 lb (111 kg)
Heavy Stack	305 lb (138 kg)
Standard Weight	565 lb (257 kg)
Heavy Weight	625 lb (284 kg)
Color	Available in 15 frame colors or a virtually unlimited variety of custom colors, 33 upholstery colors and 4 enclosure styles



Prestige Total Access Seated Leg Curl

The 12-piece Total Access line not only meets, but exceeds Inclusive Fitness Initiative (IFI) standards. Providing fitness facilities with a complete cardio and strength solution that accommodates exercisers of all abilities to train in a safe, controlled environment.

FEATURES

- **Five position adjustable calf pad:** Accommodates different lower leg lengths.
- **Thigh pad hold-down mechanism:** Allows the thighs to be secured above the knee for reduced shear force on the knee joint while keeping it in a stable position.
- **Raised numbers and large font on Range Limited Device:** Makes start position easier to adjust and identify for visually impaired and older users.
- **Optional step:** Not included.

USER AMENITIES

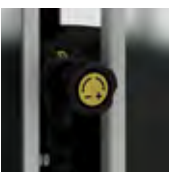

- **Placards:** Large type instructions and easy-to-understand graphics guide proper set-up, movement, and muscles trained.
- **Smartphone/tablet holder:** Your mobile device is safe and secure with our adjustable clip, designed for all smartphones and tablets. Simply clip in and go.
- **Water bottle/towel holder:** Keep your water and towel within arm's reach with our convenient water bottle and towel holder, standard on every Prestige machine.
- **Twist select incremental weight system:** Allows ease of weight selection from seated exercise position.



SPECIFICATIONS

Product Number	21461
Dimensions L x W x H	56" x 39" x 58" (142 cm x 99 cm x 147 cm)
Standard Stack	165 lb (75 kg)
Heavy Stack	205 lb (93 kg)
Standard Weight	535 lb (243 kg)
Heavy Weight	575 lb (261 kg)
Color	Available in 15 frame colors or a virtually unlimited variety of custom colors, 33 upholstery colors and 4 enclosure styles



Prestige Total Access Lat Pull

The 12-piece Total Access line not only meets, but exceeds Inclusive Fitness Initiative (IFI) standards. Providing fitness facilities with a complete cardio and strength solution that accommodates exercisers of all abilities to train in a safe, controlled environment.

FEATURES

- **Locking plunger adjustment on swing away seat:** Allows easy access for wheelchair users and one-handed seat adjustment for users with limited mobility.
- **Lever-operated single arm handle height adjustment:** Allows the bar to be adjusted for shorter and wheelchair users down to 55" (140 cm) start height from a seated position.
- **Adjustable knee restraint and seat height:** Allows shorter users and others with reduced trunk stability to maintain full flat foot contact with the floor. This permits correct pelvic positioning and avoids a round back during exercise.

USER AMENITIES



- **Placards:** Large type instructions and easy-to-understand graphics guide proper set-up, movement, and muscles trained.



- **Smartphone/tablet holder:** Your mobile device is safe and secure with our adjustable clip, designed for all smartphones and tablets. Simply clip in and go.



- **Water bottle/towel holder:** Keep your water and towel within arm's reach with our convenient water bottle and towel holder, standard on every Prestige machine.



- **Twist select incremental weight system:** Allows ease of weight selection from seated exercise position.



Swing away seat adjustment

SPECIFICATIONS

Product Number	21530
Dimensions L x W x H	55" x 55" x 90" (140cm x 140 cm x 230 cm)
Standard Stack	245 lb (111 kg)
Heavy Stack	305 lb (138 kg)
Standard Weight	475 lb (216 kg)
Heavy Weight	535 lb (243 kg)
Color	Available in 15 frame colors or a virtually unlimited variety of custom colors, 33 upholstery colors and 4 enclosure styles



FT-325 Functional Training System

The truly innovative Bravo™ Functional Training System combines unique technologies and the best aspects of selectorized and cable-based strength training equipment to offer simple, safe operation, expanded functionality and better results.

FEATURES

- **Solid, sturdy, rugged:** The same words that describe the fittest athletes also apply to our powerful functional trainer. One look at the Cybex FT-325 tells you that it's built to handle the punishment dished out by a steady stream of users in a wide range of facilities – from compact corporate and hotel exercise rooms to firehouses, police stations, and school fitness centers.
- **Make it yours:** You can match the Cybex FT-325 to the décor and color palette of your facility. Choose from standard, duo-tone, or a virtually unlimited selection of custom colors to make a dramatic branding statement with this dynamic functional trainer.
- **Dual weight stack:** Two weight stacks allow for fully independent motion and asymmetrical loads for single users, or individual stations for two users.
- **Cable adjustment:** 21 selectable positions allow cable positioning for an extraordinary variety of exercises.
- **Instructional placards:** Clearly illustrated placards show some of the more popular exercise movements.
- **Dedicated accessories:** Standard accessories include two strap handles, an ankle cuff, and a triceps rope. An optional lat pull bar is also available for even more versatility.



SPECIFICATIONS

Product Number	18000
Dimensions L x W x H	34" x 67" x 83.5" 86 cm x 170 cm x 212 cm
Weight Stacks	170 lbs (77 kg)
Machine Weight	695 lbs (315 kg)
Lifting Ratio	2:1
Color	Available in 15 frame colors or a virtually unlimited variety of custom colors and 33 upholstery colors

Free Weights

Adjustable -10 to 80° bench

The Cybex Free Weight equipment line complements the entire range of Cybex strength products. The sleek design seamlessly integrates the products into your facility's environment and provides the Cybex brand identity to your members value in strength equipment.



EXTREME STRENGTH

An effective training option every gym needs. Cybex Free Weights look good and are constructed for ease of use. They share the same design elements as Cybex Selectorized and Cybex Plate Loaded equipment for the ultimate in a well-designed gym.

- Cybex science and design in a free weight line.
- Who said hard core has to be intimidating?
- Built tough to keep looking new.

FEATURES

- Back pad has eight positions from -10° to 80°.
- Seat pad provides three positions from 0° to 20°.
- Features include wheels and a handle for easy moving that doubles as a footrest.

SPECIFICATIONS

Product Number	16001
Dimensions L x W x H	57" x 26" x 17" (145 cm x 65 cm x 44 cm)
Machine Weight	74 lb (34 kg)
Color	Available in 15 frame colors or a virtually unlimited variety of custom colors and 33 upholstery colors



Upper Body Exerciser Product Specifications

Prescribed for Progress™

Order Code: PRO1031-INT

PRO1000 Upper Body Exerciser Product Specifications

FEATURES

Upper body exercise	Helps strengthen arms and shoulders; recruits core stabilizing muscles
Bi-directional movement and resistance	Pedaling in forward and reverse provides versatility, helps prolong exercise and promotes reciprocal muscle balance
Low starting resistance	6 watts
Resistance range	191 levels of resistance - 20 levels adjustable in .1 increments
Resistance system	3 phase combination generator & eddy current brake - largest watt range in the industry
Foot rests	Foot rests included for comfort and multiple foot placement options
Easy to transport	Integrated transport wheels
Heart rate monitoring	Telemetric (chest strap required)

ACCESSIBILITY & ADJUSTABILITY

Adjustable arm cranks	3 length settings for custom fit and range of motion training
Step-through seating	Adjustable step-through allows easy entry and safe and easy access for all users
Direct wheelchair access	Seat slides off for direct wheelchair access - ADA compliant
Premium seat	Seat adjusts up/down, forward/back, swivels and reclines
360° Therapist Assist Pedals	Adjust the seat forward and back from any point around the machine
Seat Recline	Recline to any point within a 23 degree range
Seat Swivel	360 degree swivel that locks at each 90 degrees for safety
Seat height adjustment	Select seat height anywhere from 18.5"-23"
Seat removal handle	Integrated handle on seat back makes it easy to remove the seat
Accessible adjustment levers	Reach all adjustment levers from both sides of the seat
Zero-sloping forward/back seat adjustment	Adjust forward and back on level monorail for optimum control and safe positioning

INTELLI-FIT™ CONSOLE

7" LCD full color touch screen display	Touch screen with clear, simple screens and large, readable font.
Audible beep	Yes
Tactile buttons	Tactile buttons in addition to touch screen
Resistance levels	191 levels of resistance - 20 levels adjustable in .1 increments
Display feedback	Time, level, distance, METs, heart rate, calories, RPM, watts
One touch quick start	Yes
Control METs - Constant Work Program	Set constant METs level and the workload remains constant throughout the program.
Iso-Strength Program	Isokinetic program for safe, accommodating resistance
Power Burst	8-second burst of high intensity training
Cool down	Automatic cool down begins after each exercise is completed
Administrative mode	User defined settings, metric or US units of measure and other custom settings

PRO1000 Upper Body Exerciser Product Specifications (cont.)

Order Code: PR01031-INT

INTELLI-FIT™ CONSOLE (cont.)

User-defined console languages	9 languages - English, Spanish, French, German, Russian, Japanese, Chinese, Italian, Dutch			
Download results to USB flash drive	Plug USB flash drive into the Fit-Key® slot to save workout results in a .txt file			
CSAFE port and 8-volt DC power port	Yes			
USB charger	For phones and other electronic devices			
Water bottle holder, accessory tray, reading rack	Integrated			
Personal Cooling Fan	Integrated dual fans with three speeds			
Programs	Quick Start	Constant Work - METs	Hills	Heart Fit Test & Training
	Manual	Constant Work - Watts	Fit-Quik®	Power Fit Test & Training
	Heart Rate	Iso-Strength	Random	Stress Test

TECHNICAL SPECIFICATIONS

Power Requirements	Self-generating; low-voltage AC adapter, included
Maximum user weight capacity	450 lbs.
Unit weight	239 lbs.
Unit size	61" L x 30" W x 62" H
Color	Frame: Charcoal Cover: Cool Gray
Manufacturing	Assembled in USA

WARRANTY

Parts	3 years
Labor	1 year

ENHANCEMENTS

Fit-Key® software	Optional Fit-Key® software makes it easy to create specialized programs and track data
Entertainment options	Yes

ACCESSORIES

Assist Gloves	Designed for individuals who require help gripping the hand cranks. Made of heavy-duty closed cell foam that resists moisture. Flexible, comfortable and easy to clean.
Straight Grips	For those who have spasticity, weakness, or tremors in their upper extremities.
Wheelchair Platform	Provides a sturdy foundation for wheelchair use, includes tethers for stabilization.
Heavy-Duty Wheelchair Ramps	For manual and powered wheelchair access. Provides increased stabilization
Polar Chest Strap	Transmits heart rate directly to console - works on all SCIFIT products
Seat Belt	Adjustable seat belt for added security and stability. Easy to attach and remove. Storage pouch included. Fits Premium seat only.

xR6000 Specifications • Standard ○ Optional

KEY MECHANICAL FEATURES

Oversize platform	•
Step-through design	•
Oversized soft grip pedals	•
Stationary footpegs	•
Seat height adjustments	20
Seat tilt adjustments	•
MultiGrip™ handlebars	•
Stationary handlebars	•
Phone holder	•
Water bottle holder	•
Tablet/reading rack*	•
Transport wheels	•
Moving handlebar lock-out option	○
Pedal straps	○

ELECTRONIC FEATURES

Resistance levels	30
Digital contact heart rate on stationary handlebars	•
Wireless heart rate ready (ANT+™ and Polar®)	•
Fingertip controls on stationary handles	•
Console fan (3 speeds)	•
Self-powered (standard console only)	•
Mobile device charging via USB port	•
Replaceable headphone jack	•
CSAFE®	•

CONSOLE OPTIONS

Smart (pg. 40)	10" (25.4 cm) capacitive touch screen
Standard (pg. 40)	Large LED display with integrated capacitive buttons

ENTERTAINMENT OPTIONS

LG TV (pg. 41)	○
Wireless 900 Mhz (pg. 41)	○

WORKOUTS

Number of programs	14
--------------------	----

PRESET PROGRAMS

Manual	•
Random	•
Interval	•
Hill	•
Distance goal	•
Calorie goal	•

HEART RATE-CONTROLLED PROGRAMS

Fat Burn	•
Heart Rate Interval	•
Heart Rate Hill	•
Heart Rate Speed Interval	•

ADVANCED PROGRAMS

30:30 Interval	•
MMA	•
Constant Watts	•
Constant METs	•

WORKOUT BOOSTERS

X-Mode™	•
Leg Press	•
Chest Press	•

PRODUCT SPECIFICATIONS

Max user weight	400 lbs (181 kg)
Footprint (W x L)	35" x 72" (89 cm x 182 cm)
Product weight	320 lbs (145 kg)

WARRANTY

Frame	Lifetime
Parts	3 years
Labor	1 year

8 Sided Rubber Encased Dumbbells

Item SKU: SD-R

Product/Shipping Weight: Per Order Request

Product Options:

Available In :3 lb., 5 lb., 8 lb., 10 lb., 12 lb., and 15 lb. through 100 lb. in 5 lb. increments.



3-Tier Dumbbell Shelf Rack

Item SKU: GTDR-3

Product Dimensions:

Product/Shipping Weight :

240 lbs. LWH: 62 1/4" x 28" x 40 1/2"



RCK-VERSA RACK™



- 2x2 Steel 12 Gauge Upright w/ Mounting Holes every 2" for Complete Adjustability
- Trays can hold 5-30# Hex Dumbbells
Load Trays w/Slam Balls, Kettlebells, Dumbbells, Foam Rollers, Yoga Mats, etc.
- Holds Mat w/ Grommets 19" on Center up to 71" Long
- Hoops hold Medicine Balls, Wall Balls, Slam Balls, Etc.
- Stability Ball Holders also hold Bosu Balls
- Welded Endcaps
- Patent Pending
- Lifetime welds, one year parts
- Size: 72" Wide x 79" Tall x 33" Deep - 120 lbs (pictured & sold separately - accessories &/or rack)

Standard Package - RCK-VERSA1

Versa Rack

Stability Balls (55, 65 & 75cm)

Medicine Balls (6/8/10/12/15/20)

Hex Dumbbell Pairs (5/10/15/20/25)

Fitness Mats 24"x71" - 4 each

**CREATE
YOUR
OWN
PACKAGE!**

