

Sec. 4-115. - General exceptions and amendments applicable to all technical codes.

z. All buildings will be assessed as the same type building construction as originally permitted.

aa. Outside electrical disconnects will not be required for existing or new construction of single-family residence.

bb. All grease traps will need to be constructed to the engineered design indicated in the submittal or verified by a master plumber.

Sec. 4-120. - Specific Amendments to the 2021 International Building Code.

Section 101.4; change to read as follows:

101.4 Referenced codes. The other codes listed in Sections 101.4.1 through 101.4.8 and referenced elsewhere in this code, when specifically adopted, shall be considered part of the requirements of this code to the prescribed extent of each such reference. Whenever amendments have been adopted to the referenced codes and standards, each reference to said code and standard shall be considered to reference the amendments as well. Any reference to NFPA 70 or the Electrical Code shall mean the Electrical Code as adopted.

Section 101.4.8; add the following:

101.4.8 Electrical. The provisions of the Electrical Code shall apply to the installation of electrical systems, including alterations, repairs, replacement, equipment, appliances, fixtures, fittings and appurtenances thereto.

Sections 103 and 103.1; amend to insert the Department Name

~~CODE COMPLIANCE AGENCY~~ [BUILDING SERVICES DEPARTMENT]

103.1 Creation of enforcement agency. The **[BUILDING SERVICES DEPARTMENT]** is hereby created and the official in charge thereof shall be known as the *building official*.

[Remainder Unchanged]

Section 104.10.1; Flood hazard areas. *Shall follow all requirements of Keller's Code of Ordinances and any other adopted code.*

Section 105.2 Work exempt from permit; under sub-title entitled "Building" delete items 1, 2, 10 and 11 and re-number as follows:

Building:

- ~~1.~~ One-story detached accessory structures used as tool and storage sheds, playhouses and similar uses, provided the floor area does not exceed 120 square feet (11 m²).
- ~~2.~~ Fences not over 7 feet (1829 mm) high.
- ~~3.~~ 1. (Remainder Unchanged)
- ~~4.~~ 2. (Remainder Unchanged)
- ~~5.~~ 3. (Remainder Unchanged)
- ~~6.~~ 4. (Remainder Unchanged)
- ~~7.~~ 5. (Remainder Unchanged)
- ~~8.~~ 6. (Remainder Unchanged)
- ~~9.~~ 7. (Remainder Unchanged)
- ~~10.~~ Shade cloth structures constructed for nursery or agricultural purposes, not including service systems.
- ~~11.~~ 8. (Remainder Unchanged)
- ~~12.~~ 9. (Remainder Unchanged)
- ~~13.~~ 10. (Remainder Unchanged)

Section 109; add Section 109.7 to read as follows:

109.7 Re-inspection Fee. A fee as established by city council resolution may be charged when:

1. The inspection called for is not ready when the inspector arrives;
2. No building address or permit card is clearly posted;
3. City approved plans are not on the job site available to the inspector;
4. The building is locked or work otherwise not available for inspection when called;
5. The job site is red-tagged twice for the same item;
6. The original red tag has been removed from the job site.
7. Failure to maintain erosion control, trash control or tree protection.

Any re-inspection fees assessed shall be paid before any more inspections are made on that job site.

Section 110.3.5; Lath, gypsum board and gypsum panel product inspection; Delete exception

Exception: ~~Gypsum board and gypsum panel products that are not part of a fire resistance rated assembly or a shear assembly.~~

Section 202; amend definition of Ambulatory Care Facility as follows:

AMBULATORY CARE FACILITY. Buildings or portions thereof used to provide medical, surgical, psychiatric, nursing or similar care on a less than 24-hour basis to ~~individuals~~ persons who are rendered incapable of self-preservation by the services provided ~~or staff has accepted responsibility for care recipients already incapable.~~ This group may include but not be limited to the following:

- Dialysis centers
- Sedation dentistry
- Surgery centers
- Colonic centers
- Psychiatric centers

Section 202; ~~add~~ amend definition of "Repair Garage" as follows:

REPAIR GARAGE. A building, structure or portion thereof used for servicing or repairing motor vehicles. This occupancy shall also include garages involved in minor repair, modification and servicing of motor vehicles for items such as lube changes, inspections, windshield repair or replacement, shocks, minor part replacement and other such minor repairs.

Section 202; amend definition of SPECIAL INSPECTOR to read as follows:

SPECIAL INSPECTOR. A qualified person employed or retained by an approved agency who shall prove to the satisfaction of the registered design professional in responsible charge and approved by the Building Official as having the competence necessary to inspect a particular type of construction requiring special inspection.

Section 202; Amend definition to read as follows:

HIGH-RISE BUILDING. A building with an occupied floor located more than ~~75~~ 55 feet (~~22 860 mm~~) (16 764 mm) above the lowest level of fire department vehicle access.

Section 303.1.3; add a sentence to read as follows:

303.1.3 Associated with Group E occupancies. A room or space used for assembly purposes that is associated with a Group E occupancy is not considered a separate occupancy, except when applying the assembly requirements of Chapters 10 and 11

Section 304.1; add the following to the list of occupancies:

Fire stations

Police stations with detention facilities for 5 or less

Section 307.1.1; add the following sentence to Exception 4:

4. Cleaning establishments... *{Text unchanged}* ...with Section 707 or 1-hour horizontal assemblies constructed in accordance with Section 711 or both. See also IFC Chapter 21, Dry Cleaning Plant provisions.

Section 403.1, Exception 3; change to read as follows:

The open-air portion of a building *[remainder unchanged]*

Section 403.3, Automatic Sprinkler System. Delete exception;

Section 403.3.2; change to read as follows:

[F] 403.3.2 Water supply to required fire pumps. In buildings that are more than ~~420~~ 120 feet (36.5 m) in building height, required fire pumps shall be supplied by connections to no fewer than two water mains located in different streets. Separate supply piping shall be provided between each connection to the water main and the pumps. Each connection and the supply piping between the connection and the pumps shall be sized to supply the flow and pressure required for the pumps to operate.

Section 403.3.2; change to read as follows:

Section 404.10 Exit Stairways in an atrium. Where an atrium contains an ~~interior~~ exit access stairway all the following shall be met:

Section 406.3.3.1 Carport separation; add sentence to read as follows:

A fire separation is not required between a Group R-2 and U carport provided that the carport is entirely open on all sides and that the distance between the two is at least 10 feet (3048 mm).

Section 423.5.1; change to read as follows:

423.5.1 Required occupant capacity. The required occupant capacity of the storm shelter shall include all of the buildings on the site and shall be the ~~greater of the following:~~

- ~~1. The Total occupant load of the classrooms, vocational rooms and offices in the Group E occupancy.~~
- ~~2. The occupant load of the largest indoor assembly space that is associated with the Group E occupancy.~~

Exceptions:

1. Where a new building is being added on an existing Group E site, and where the new building is not of sufficient size to accommodate the required occupant capacity of the storm shelter for all of the buildings on the site, the storm shelter shall at a minimum accommodate the required occupant capacity for the new building.
2. Where approved by the building official, the required occupant capacity of the shelter shall be permitted to be reduced by the occupant capacity of any existing storm shelters on the site.
3. Where approved by the building official, the actual number of occupants for whom each occupied space, floor or building is designed, although less than those determined by occupant load calculation, shall be permitted to be used in the determination of the required design occupant capacity for the storm shelter.

Section 503.1.; add sentence to read as follows:

503.1. General. [Existing Text to remain]

Where a building contains more than one distinct type of construction, the building shall comply with the most restrictive area, height, and stories, for the lesser type of construction or be separated by fire walls, except as allowed in Section 510.

Table 506.2; delete footnote i from table

~~i. The maximum allowable area for a single-story non-sprinklered Group U greenhouse is permitted to be 9000 square feet or the allowable area shall be permitted to comply with Table C102.1 of Appendix C.~~

Section 506.3.1; add sentence to read as follows:

506.3.1 Minimum percentage of perimeter. [Existing Text remains]

In order to be considered as accessible, if not in direct contact with a street or fire lane, a minimum 10-foot-wide pathway meeting fire department access from the street or approved fire lane shall be provided.

Section 708.4.2; change sentence to read as follows:

708.4.2 Fireblocks and draftstops in combustible construction. [Body of text unchanged]

Exceptions:

1. Buildings equipped with an automatic sprinkler system installed throughout in accordance with Section 903.3.1.1, or in accordance with Section 903.3.1.2 provided that sprinkler protection is provided in the space between the top of the fire partition and the underside of the floor or roof sheathing, deck or slab above as required for systems complying with Section 903.3.1.1. Portions of buildings containing concealed spaces filled with noncombustible insulation as permitted for sprinkler omission shall not apply to this exception for draftstopping. [Remainder unchanged]

Section 718.3; change sentence to read as follows:

718.3 Draftstopping in floors. [Body of text unchanged]

Exceptions: Buildings equipped throughout with an automatic sprinkler system in accordance with Section 903.3.1.1. and provided that in combustible construction, sprinkler protection is provided in the floor space.

Section 718.4; change sentence to read as follows:

718.4 Draftstopping in attics. *[Body of text unchanged]*

Exceptions: Buildings equipped throughout with an automatic sprinkler system in accordance with Section 903.3.1.1 and provided that in combustible construction, sprinkler protection is provided in the attic space.

Section 901.6.1; add Section 901.6.1.1 to read as follows:

901.6.1.1 Standpipe Testing. Building owners/managers must maintain and test standpipe systems as per NFPA 25 requirements. The following additional requirements shall be applied to the testing that is required every 5 years:

1. The piping between the Fire Department Connection (FDC) and the standpipe shall be backflushed or inspected by approved camera when foreign material is present or when caps are missing, and also hydrostatically tested for all FDC's on any type of standpipe system. Hydrostatic testing shall also be conducted in accordance with NFPA 25 requirements for the different types of standpipe systems.
2. For any manual (dry or wet) standpipe system not having an automatic water supply capable of flowing water through the standpipe, the tester shall connect hose from a fire hydrant or portable pumping system (as approved by the *fire code official*) to each FDC, and flow water through the standpipe system to the roof outlet to verify that each inlet connection functions properly. Confirm that there are no open hose valves prior to introducing water into a dry standpipe. There is no required pressure criteria at the outlet. Verify that check valves function properly and that there are no closed control valves on the system.
3. Any pressure relief, reducing, or control valves shall be tested in accordance with the requirements of NFPA 25. All hose valves shall be exercised.
4. If the FDC is not already provided with approved caps, the contractor shall install such caps for all FDC's as required by the *fire code official*.
5. Upon successful completion of standpipe test, place a blue tag (as per Texas Administrative Code, Fire Sprinkler Rules for Inspection, Test and Maintenance Service (ITM) Tag) at the bottom of each standpipe riser in the building. The tag shall be check-marked as "Fifth Year" for Type of ITM, and the note on the back of the tag shall read "5 Year Standpipe Test" at a minimum.

6. The procedures required by Texas Administrative Code Fire Sprinkler Rules with regard to Yellow Tags and Red Tags or any deficiencies noted during the testing, including the required notification of the local Authority Having Jurisdiction (*fire code official*) shall be followed.
7. Additionally, records of the testing shall be maintained by the owner and contractor, if applicable, as required by the State Rules mentioned above and NFPA 25.
8. Standpipe system tests where water will be flowed external to the building shall not be conducted during freezing conditions or during the day prior to expected nighttime freezing conditions.
9. Contact the *fire code official* for requests to remove existing fire hose from Class II and III standpipe systems where employees are not trained in the utilization of this firefighting equipment. All standpipe hose valves must remain in place and be provided with an approved cap and chain when approval is given to remove hose by the *fire code official*.

Section 903.1.1; change to read as follows:

903.1.1 Alternative Protection. Alternative automatic fire-extinguishing systems complying with Section 904 shall be permitted ~~instead of~~ in addition to automatic sprinkler protection where recognized by the applicable standard ~~and, or as~~ approved by the *fire code official*.

Section 903.2; add paragraph to read as follows and delete the exception for telecommunications buildings:

Automatic Sprinklers shall not be installed in elevator machine rooms, elevator machine spaces, and elevator hoistways, other than pits where such sprinklers would not necessitate shunt trip requirements under any circumstances. Storage shall not be allowed within the elevator machine room. Signage shall be

provided at the entry doors to the elevator machine room indicating “ELEVATOR MACHINERY – NO STORAGE ALLOWED.”

Section 903.2.4.2; change to read as follows:

903.2.4.2 Group F-1 distilled spirits. An automatic sprinkler system shall be provided throughout a Group F-1 fire area used for the manufacture of distilled spirits involving more than 120 gallons of distilled spirits

(>16% alcohol) in the fire area at any one time.

Section 903.2.9.4 and 903.2.9.5; delete Exception to 903.2.9.4 and add Section 903.2.9.5 to read as follows:

903.2.9.5 Self-Service Storage Facility. An automatic sprinkler system shall be installed throughout all self-service storage facilities.

Section 903.2.9.4 and 903.2.9.5; delete Exception to 903.2.9.4 and add Section 903.2.9.5 to read as follows:

903.2.9.5 Self-Service Storage Facility. An automatic sprinkler system shall be installed throughout all self-service storage facilities.

Section 903.2.11; change 903.2.11.3 and add 903.2.11.7, 903.2.11.8, and 903.2.11.9 as follows:

903.2.11.3 Buildings 55 35 feet or more in height. An automatic sprinkler system shall be installed throughout buildings that have one or more stories with an occupant load of 30 or more, other than penthouses in compliance with Section 1510 of the International Building Code, located 55 35 feet (16 764 10 668 mm) or more above the lowest level of fire department vehicle access, measured to the finished floor.

Exceptions:

2. Occupancies in Group F-2.

903.2.11.7 High-Piled Combustible Storage. For any building with a clear height exceeding 12 feet (4572 mm), see Chapter 32 to determine if those provisions apply.

903.2.11.8 Spray Booths and Rooms. New and existing spray booths and spraying rooms shall be protected by an approved automatic fire-extinguishing system.

903.2.11.9 Buildings Over 6,000 sq. ft. An automatic sprinkler system shall be installed throughout all buildings with a building area 6,000 sq. ft. or greater and in all existing buildings that are enlarged to be 6,000 sq. ft. or greater. For the purpose of this provision, fire walls shall not define separate buildings.

Exception: Open parking garages in compliance with Section 406.5 if the *International Building Code* where all the following conditions apply:

- a. The structure is freestanding.
- b. The structure does not contain any mixed uses, accessory uses, storage rooms, electrical rooms, elevators or spaces used or occupied for anything other than motor vehicle parking.
- c. The structure does not exceed 3 stories.
- d. An approved fire apparatus access road is provided around the entire structure.

Section 903.3.1.1.1; change to read as follows:

903.3.1.1.1 Exempt Locations. When approved by the fire code official, automatic sprinklers shall not be required in the following rooms or areas where such ...*{text unchanged}*... because it is damp, of fire-resistance-rated construction or contains electrical equipment.

1. Any room where the application of water, or flame and water, constitutes a serious life or fire hazard.
2. Any room or space where sprinklers are considered undesirable because of the nature of the contents, when approved by the fire code official.
3. Generator and transformer rooms, under the direct control of a public utility, separated from the remainder of the building by walls and floor/ceiling or roof/ceiling assemblies having a fire-resistance rating of not less than 2 hours.
- ~~4. In rooms or areas that are of noncombustible construction with wholly noncombustible contents.~~
5. ~~Fire service access~~ Elevator machine rooms, and machinery spaces, and hoistways, other than pits where such sprinklers would not necessitate shunt trip requirements under any circumstances.
6. {Delete.}

Section 903.3.1.2; change to read as follows:

903.3.1.2 NFPA 13R sprinkler systems. Automatic sprinkler systems in Group R occupancies shall be permitted to be installed throughout in accordance with NFPA 13R where the Group R occupancy meets all of the following conditions:

1. Four stories or less above grade plane.
2. The floor level of the highest story is ~~30~~ 35 feet (~~9144~~ 10668 mm) or less above the lowest level of fire department vehicle access.
3. The floor level of the lowest story is ~~30~~ 35 feet (~~9144~~ 10668 mm) or less below the lowest level of fire department vehicle access.

{No change to remainder of section.}

Section 903.3.1.2.2; change to read as follows:

903.3.1.2.2 Corridors and balconies ~~in the means of egress~~. Sprinkler protection shall be provided in all corridors and for all balconies. ~~in the means of egress where any of the following conditions apply: {Delete the rest of this section.}~~

Section 903.3.1.2.3; delete section and replace as follows:

Section 903.3.1.2.3 Attached Garages and Attics. Sprinkler protection is required in attached garages, and in the following attic spaces:

1. Attics that are used or intended for living purposes or storage shall be protected by an automatic sprinkler system.
2. Where fuel-fired equipment is installed in an unsprinklered attic, not fewer than one quick-response intermediate temperature sprinkler shall be installed above the equipment.
3. Attic spaces of buildings that are two or more stories in height above grade plane or above the lowest level of fire department vehicle access.
4. Group R-4, Condition 2 occupancy attics not required by Item 1 or 3 to have sprinklers shall comply with one of the following:
 - 4.1. Provide automatic sprinkler system protection.
 - 4.2. Provide a heat detection system throughout the attic that is arranged to activate the building fire alarm system.
 - 4.3. Construct the attic using noncombustible materials.
 - 4.4. Construct the attic using fire-retardant-treated wood complying with Section 2303.2 of the International Building Code.
 - 4.5. Fill the attic with noncombustible insulation.

Section 903.3.1.3; change to read as follows:

903.3.1.3 NFPA 13D Sprinkler Systems. *Automatic sprinkler systems* installed in one- and two-family *dwelling*s; Group R-3; Group R-4, Condition 1; and *townhouses* shall be permitted to be installed throughout in accordance with NFPA 13D or in accordance with state law.

Section 903.3.1.4; add to read as follows:

[F] 903.3.1.4 Freeze protection. Freeze protection systems for automatic fire sprinkler systems shall be in accordance with the requirements of the applicable referenced NFPA standard and this section.

903.3.1.4.1 Attics. Only dry pipe, preaction, or listed antifreeze automatic fire sprinkler systems shall be allowed to protect attic spaces.

Exception: Wet-pipe fire sprinkler systems shall be allowed to protect non-ventilated attic spaces where:

1. The attic sprinklers are supplied by a separate floor control valve assembly to allow ease of draining the attic system without impairing sprinklers throughout the rest of the building, and
2. Adequate heat shall be provided for freeze protection as per the applicable referenced NFPA standard, and
3. The attic space is a part of the building's thermal, or heat, envelope, such that insulation is provided at the roof deck, rather than at the ceiling level.

903.3.1.4.2 Heat trace/insulation. Heat trace/insulation shall only be allowed where approved by the fire code official for small sections of large diameter water-filled pipe.

Section 903.3.5; add a second paragraph to read as follows:

Water supply as required for such systems shall be provided in conformance with the supply requirements of the respective standards; however, every water-based fire protection system shall be designed with a 10-psi safety factor. Reference Section 507.4 for additional design requirements.

Section 903.4; add a second paragraph after the exceptions to read as follows:

Sprinkler and standpipe system water-flow detectors shall be provided for each floor tap to the sprinkler system and shall cause an alarm upon detection of water flow for more than 45 seconds. All control valves in the sprinkler and standpipe systems except for fire department hose connection valves shall be electrically supervised to initiate a supervisory signal at the central station upon tampering.

Section 903.4.2; add second paragraph to read as follows:

The alarm device required on the exterior of the building shall be a weatherproof horn/strobe notification appliance with a minimum 75 candela strobe rating, installed as close as practicable to the fire department connection.

Section 905.2; change to read as follows:

905.2 Installation Standard. Standpipe systems shall be installed in accordance with this section and NFPA 14. Manual dry standpipe systems shall be supervised with a minimum of 10 psig and a maximum of 40 psig air pressure with a high/low alarm.

Section 905.3; add Section 905.3.9 and exception to read as follows:

905.3.9 Buildings Exceeding 10,000 sq. ft. In buildings exceeding 10,000 square feet in area per story and where any portion of the building's interior area is more than 200 feet (60960 mm) of travel, vertically and horizontally, from the nearest point of fire department vehicle access, Class I automatic wet or manual wet standpipes shall be provided.

Exceptions:

1. Automatic dry, semi-automatic dry, and manual dry standpipes are allowed as provided for in NFPA 14 where approved by the fire code official.
2. R-2 occupancies of four stories or less in height having no interior corridors.

Section 905.4; change Items 1, 3, and 5, and add Item 7 to read as follows:

1. In every required ~~interior~~ exit stairway, a hose connection shall be provided for each story above and below grade plane. Hose connections shall be located at an intermediate landing between stories, unless otherwise approved by the fire code official.

Exception: {No change.}

2. {No change.}
3. In every exit passageway, at the entrance from the exit passageway to other areas of a building.

Exception: Where floor areas adjacent to an exit passageway are reachable from an ~~interior~~ exit stairway hose connection by a {remainder of text unchanged}

4. {No change.}
5. Where the roof has a slope less than 4 units vertical in 12 units horizontal (33.3-percent slope), each standpipe shall be provided with a two-way a-hose connection shall be located to serve the roof or at the highest landing of an ~~interior~~ exit stairway with stair access to the roof provided in accordance with Section 1011.12.
6. {No change.}
7. When required by this Chapter, standpipe connections shall be placed adjacent to all required exits to the structure and at two hundred feet (200') intervals along major corridors thereafter, or as otherwise approved by the fire code official.

Section 905.8; change to read as follows:

905.8 Dry standpipes. Dry standpipes shall not be installed.

Exception: Where subject to freezing and in accordance with NFPA 14. Additionally, manual dry standpipe systems shall be supervised with a minimum of 10 psig and a maximum of 40 psig air pressure with a high/low Supervisory alarm.

Section 905.9; add a second paragraph after the exceptions to read as follows:

Sprinkler and standpipe system water-flow detectors shall be provided for each floor tap to the sprinkler system and shall cause an alarm upon detection of water flow for more than 45 seconds. All control valves in the sprinkler and standpipe systems except for fire department hose connection valves shall be electrically supervised to initiate a supervisory signal at the central station upon tampering.

Section 906.1(1); delete Exception #3 as follows:

~~3. In storage areas of Group S occupancies where forklift, powered industrial truck or powered cart operators are the primary occupants,~~

~~fixed extinguishers, as specified in NFPA 10, shall not be required where in accordance with all of the following:~~

~~3.1. Use of vehicle-mounted extinguishers shall be approved by the fire code official.~~

~~3.2. Each vehicle shall be equipped with a 10-pound, 40A:80B:C extinguisher affixed to the vehicle using a mounting bracket approved~~

~~by the extinguisher manufacturer or the fire code official for vehicular use.~~

~~3.3. Not less than two spare extinguishers of equal or greater rating shall be available on-site to replace a discharged extinguisher.~~

~~3.4. Vehicle operators shall be trained in the proper operation, use and inspection of extinguishers.~~

~~3.5. Inspections of vehicle-mounted extinguishers shall be performed daily.~~

Section 907.1; add Section 907.1.4 to read as follows:

907.1.4 Design Standards. Where a new fire alarm system is installed, the devices shall be addressable. Fire alarm systems utilizing more than 20 smoke detectors shall have analog initiating devices.

Section 907.2.1; change to read as follows:

907.2.1 Group A. A manual fire alarm system that activates the occupant notification system in accordance with Section 907.5 shall be installed in Group A occupancies ~~where the~~ having an occupant load ~~due to the assembly occupancy is of~~ 300 or more persons, or where the ~~Group A~~ occupant load is more than 100 persons above or below the *lowest level of exit discharge*. Group A occupancies not separated from one another in accordance with Section 707.3.10 of the *International Building Code* shall be considered as a single occupancy for the purposes of applying this section. Portions of Group E occupancies occupied for assembly purposes shall be provided with a fire alarm system as required for the Group E occupancy.

Exception: {No change.}

Activation of fire alarm notification appliances shall:

1. Cause illumination of the *means of egress* with light of not less than 1 foot-candle (11 lux) at the walking surface level, and
2. Stop any conflicting or confusing sounds and visual distractions.

Section 907.2.3; change to read as follows:

907.2.3 Group E. A manual fire alarm system that initiates the occupant notification signal utilizing an emergency voice/alarm communication system meeting the requirements of Section 907.5.2.2 and installed in accordance with Section 907.6 shall be installed in Group E educational occupancies. When *automatic sprinkler systems* or smoke detectors are installed, such systems or detectors shall be connected to the building fire alarm system. An approved smoke detection system shall be installed in Group E day care occupancies. Unless separated by a minimum of 100' open space, all buildings, whether portable buildings or the main building, will be considered one building for alarm occupant load consideration and interconnection of alarm systems.

Exceptions:

- {No change.}
 - 1.1. Residential In-Home day care with not more than 12 children may use interconnected single station detectors in all habitable rooms. (For care of more than five children 2 1/2

or less years of age, see Section 907.2.6.) {No change to remainder of exceptions.}

Section 907.2.10; change to read as follows:

907.2.10 Group S. A manual fire alarm system that activates the occupant notification system in accordance with Section 907.5 shall be installed in Group S public- and self-storage occupancies ~~three stories or greater in height~~ for interior corridors and interior common areas. Visible notification appliances are not required within storage units.

Exception: {No change.}

Section 907.2.13, Exception 3; change to read as follows:

3. Open air portions of buildings with an occupancy in Group A-5 in accordance with Section 303.1 of the International Building Code; however, this exception does not apply to accessory uses including but not limited to sky boxes, restaurants, and similarly enclosed areas.

Section 907.4.2; add Section 907.4.2.7 to read as follows:

907.4.2.7 Type. Manual alarm initiating devices shall be an approved double action type.

Section 907.6.1; add Section 907.6.1.1 to read as follows:

907.6.1.1 Wiring Installation. All fire alarm systems shall be installed in such a manner that a failure of any single initiating device or single open in an initiating circuit conductor will not interfere with the normal operation of other such devices. All signaling line circuits (SLC) shall be installed in such a way that a single open will not interfere with the operation of any addressable devices (Class A). Outgoing and return SLC conductors shall be installed in accordance with NFPA 72 requirements for Class A circuits and shall have a minimum of four feet separation horizontal and one foot vertical between supply and return circuit conductors. The initiating device circuit (IDC) from a signaling line circuit interface device may be wired Class B, provided the distance from the interface device to the initiating device is ten feet or less.

Section 907.6.3; delete all four Exceptions.

Section 907.6.6; add sentence at end of paragraph to read as follows:

See 907.6.3 for the required information transmitted to the supervising station.

Section 910.2; change read and change Exception 2 and 3 to read as follows:

910.2 Where required. Smoke and heat vents or a mechanical smoke removal system shall be installed as required by Sections 910.2.1, 910.2.2, and 910.3.2.

2. Only manual smoke and heat removal shall ~~not~~ be required in areas of buildings equipped with early suppression fast-response (ESFR) sprinklers. Automatic smoke and heat removal is prohibited.
3. Only manual smoke and heat removal shall ~~not~~ be required in areas of buildings equipped with control mode special application sprinklers with a response time index of $50(m^*S)^{1/2}$ or less that are listed to control a fire in stored commodities with 12 or fewer sprinklers. Automatic smoke and heat removal is prohibited.

Section 910.2.3; add to read as follows:

910.2.3 Group H. Buildings and portions thereof used as a Group H occupancy as follows:

1. In occupancies classified as Group H-2 or H-3, any of which are more than 15,000 square feet (1394 m²) in single floor area.

Exception: Buildings of noncombustible construction containing only noncombustible materials.

2. In areas of buildings in Group H used for storing Class 2, 3, and 4 liquid and solid oxidizers, Class 1 and unclassified detonable organic peroxides, Class 3 and 4 unstable (reactive) materials, or Class 2 or 3 water-reactive materials as required for a high-hazard commodity classification.

Exception: Buildings of noncombustible construction containing only noncombustible materials.

Section 910.4.3.1; change to read as follows:

910.4.3.1 Makeup Air. Makeup air openings shall be provided within 6 feet (1829 mm) of the floor level. Operation of makeup air openings shall be ~~manual or~~ automatic. The minimum gross area of makeup air inlets shall be 8 square feet per 1,000 cubic feet per minute (0.74 m² per 0.4719 m³/s) of smoke exhaust.

Section 912.2; add Section 912.2.3 to read as follows:

912.2.3 Hydrant Distance. An approved fire hydrant shall be located within 100 feet of the fire department connection as the fire hose lays along an unobstructed path.

Section 1006.2.1 change exception 3 to read as follows;

Section 1006.2.1 Egress based on occupant load and common path of egress travel distance.

3. Unoccupied rooftop mechanical rooms and penthouses are not required to comply with the common path of egress travel distance measurement.

Section 1009.8 Two Way Communication; add the following Exception 7:

[Text Remains]

Exceptions:

7. Buildings regulated under State Law and built in accordance with State registered plans, including variances or waivers granted by the State, shall be deemed to be in compliance with the requirements of Section 1009 and Chapter 11.

Section 1010.2.5 Bolt Locks; amend exceptions 3 and 4 as follows:

Exceptions:

3. *Where a pair of doors serves an occupant load of less than 50 persons in a Group B, F, M or S occupancy. (remainder unchanged)*

4. *Where a pair of doors serves a Group A, B, F, M or S occupancy (remainder unchanged)*

Section 1020.2 Construction; add new exception 6 as follows:

6. In unsprinklered group B occupancies, corridor walls and ceilings need not be of fire-resistive construction within a single tenant space when the space is equipped with approved automatic smoke-detection within the corridor. The actuation of any detector must activate self-annunciating alarms audible in all areas within the corridor. Smoke detectors must be connected to an approved automatic fire alarm system where such system is provided.

Section 1030.1.1.1 Spaces under grandstands and bleachers; delete this section

Section 1101.1 Scope; add exception to Section 1101.1 as follows:

Exception: Components of projects regulated by and registered with Architectural Barriers Division of Texas Department of Licensing and Regulation shall be deemed to be in compliance with the requirements of this chapter.

Section 1809.5.1 Frost Protection at required exits; delete this section

Section 2702.5; added to read as follows:

Section 2702.5 Designated Critical Operations Areas (DCOA): In areas within a facility or site requiring continuous operation for the purpose of public safety, emergency management, national security or business continuity, the power systems shall comply with NFPA 70 Article 708.

Section 2901.1; add a sentence to read as follows:

[P] 2901.1 Scope. *{existing text to remain}* The provisions of this Chapter are meant to work in coordination with the provisions of Chapter 4 of the International Plumbing Code. Should any conflicts arise between the two chapters, the Building Official shall determine which provision applies.

Section 2902.1; add a second paragraph to read as follows:

In other than E Occupancies, the minimum number of fixtures in Table 2902.1 may be lowered, if requested in writing, by the applicant stating reasons for a reduced number and approved by the Building Official.

Table 2902.1; add footnote g to read as follows:

g. Drinking fountains are not required in M Occupancies with an occupant load of 100 or less, B Occupancies with an occupant load of 25 or less, and for dining and/or drinking establishments.

Add Section 2902.1.4 to read as follows:

2902.1.4 Additional fixtures for food preparation facilities. In addition to the fixtures required in this Chapter, all food service facilities shall be provided with additional fixtures set out in this section.

2902.1.4.1 Hand washing lavatory. At least one hand washing lavatory shall be provided for use by employees that is accessible from food preparation, food dispensing and ware washing areas. Additional hand washing lavatories may be required based on convenience of use by employees.

2902.1.4.2 Service sink. In new or remodeled food service establishments, at least one service sink or one floor sink shall be provided so that it is conveniently located for the cleaning of mops or similar wet floor cleaning tool and for the disposal of mop water and similar liquid waste. The location of the service sink(s) and/or mop sink(s) shall be approved by the <Jurisdiction's> health department.

Section 3002.1 Hoistway Enclosure Protection required. Add exceptions as follows:

Exceptions:

1. Elevators completely located within atriums shall not require hoistway enclosure protection.
2. Elevators in open or enclosed parking garages that serve only the parking garage, shall not require hoistway enclosure protection.

Sec. 4-130. - Specific Amendments to the 2021 International Residential Code.

Section R102.4; change to read as follows:

R102.4 Referenced codes and standards. The *codes*, when specifically adopted, and standards referenced in this *code* shall be considered part of the requirements of this *code* to the prescribed extent of each such reference and as further regulated in Sections R102.4.1 and R102.4.2. Whenever amendments have been adopted to the referenced *codes* and standards, each reference to said *code* and standard shall be considered to reference the amendments as well. Any reference made to NFPA 70 or the *Electrical Code* shall mean the *Electrical Code* as adopted

Section R103 and R103.1 amend to insert the Department Name

~~DEPARTMENT OF BUILDING SAFETY~~ [BUILDING SERVICES DEPARTMENT]

R103.1 Creation of enforcement agency. The ~~Department of Building Safety~~ [**BUILDING SERVICES DEPARTMENT**] is hereby created and the official in charge thereof shall be known as the *building official*.

Section R104.10.1 Flood Hazard areas; delete this section.

Section R105.3.1.1& R106.1.4; delete these sections.

Section R202; change definition of "Townhouse Unit" to read as follows:

TOWNHOUSE UNIT. A single-family dwelling unit separated by property lines in a townhouse that extends from foundation to roof and that has a yard or public way on not less than two sides

Table R301.2 (1); fill in as follows:

GROUND SNOW LOAD	WIND DESIGN				SEISMIC DESIGN CATEGORY ^f	SUBJECT TO DAMAGE FROM			WINTER DESIGN TEMP ^e	ICE BARRIER UNDER-LAYMENT ^h	FLOOD HAZARDS ^g	AIR FREEZING INDEX ⁱ	MEAN ANNUAL TEMP ^j
	SPEED ^d (MPH)	Topographic Effects ^k	Special Wind Region ^l	Windborne Debris Zone ^m		Weathering ^a	Frost Line Depth ^b	Termite ^c					
5 lb/ft	115 (3 sec-gust)/ 76 fastest mile	No	No	No	A	Moderate	6"	Very Heavy	22 ^o F	No	Local Code	150	64.9 ^o F

Delete remainder of table Manual J Design Criteria and footnote N

Section R302.1; add exception #6 to read as follows:

Exceptions: {previous exceptions unchanged}

6. Open non-combustible carport structures may be constructed when also approved within adopted ordinances.

Section R302.3; add Exception #3 to read as follows:

Exceptions:

1. {existing text unchanged}
2. {existing text unchanged}

3. Two-family dwelling units that are also divided by a property line through the structure shall be separated as required for townhouses.

Section R302.2.6; delete exception #6:

Exceptions: {previous exceptions unchanged}

- ~~6. Townhouse units protected by a fire sprinkler system complying with Section P2904 or NFPA 13D.~~

Section R302.5.1; change to read as follows:

R302.5.1 Opening protection. Openings from a private garage directly into a room used for sleeping purposes shall not be permitted. Other openings between the garage and residence shall be equipped with solid wood doors not less than 13/8 inches (35 mm) in thickness, solid or honeycomb core steel doors not less than 13/8 inches (35 mm) thick, or 20-minute fire-rated doors. ~~Equipped with a self-closing or automatic closing device.~~

Section R303.3, Exception; amend to read as follows:

Exception: {existing text unchanged} Spaces containing only a water closet or water closet and a lavatory may be ventilated with an approved mechanical recirculating fan or similar device designed to remove odors from the air.

R307.3 Blocking. Required at one toilet at grade level. Blocking per Sec. R307.4 and Figure 307.4, shall be installed at rear wall and one wall adjacent to toilet at the lowest living level where a toilet is provided.

R307.4 Blocking. Blocking may be 1/2" plywood or equivalent or 2 x solid wood blocking flush with wall.

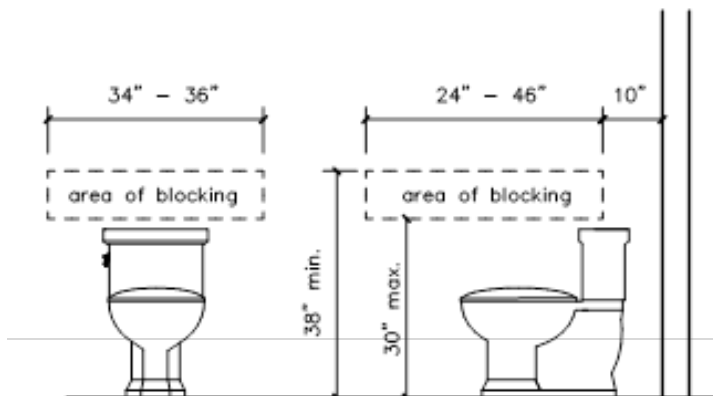

Figure 307.4

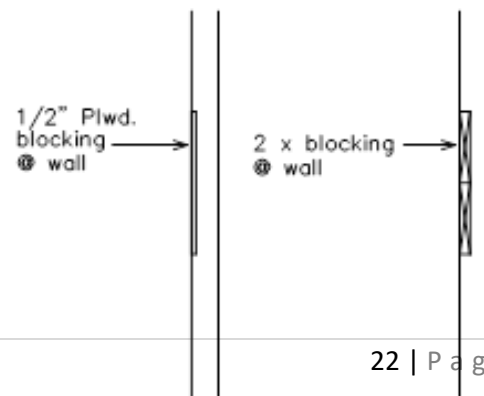

Figure 307.4

Section R313.2 One and Two Family Dwellings; Delete this section and subsection in their entirety.

Section R315.2.2 Alterations, repairs and additions; amend to read as follows:

Exception:

1. [existing text remains]
2. Installation, alteration or repairs of all electrically powered mechanical systems or plumbing appliances.

Section R322 Flood Resistant Construction; deleted section.

Section 327.1.1; add to read as follows:

Section 327.1.1 Adjacency to Structural Foundation. Depth of the swimming pool and spa shall maintain a ratio of 1:1 from the nearest building foundation or footing of a retaining wall.

Exception:

A sealed engineered design drawing of the proposed new structure shall be submitted for approval.

Section R401.2; amended by adding a new paragraph following the existing paragraph to read as follows.

Section R401.2. Requirements. *{existing text unchanged}* ...

Every foundation and/or footing, or any size addition to an existing post-tension foundation, regulated by this code shall be designed and sealed by a Texas-registered engineer.

Section R602.6.1; amend the following:

R602.6.1 Drilling and notching of top plate. When piping or ductwork is placed in or partly in an exterior wall or interior load-bearing wall, necessitating cutting, drilling or notching of the top plate by more than 50 percent of its width, a galvanized metal tie not less than 0.054 inch thick (1.37 mm) (16 Ga) and ~~1 ½ inches (38 mm)~~ 5 inches (127 mm) wide shall be fastened across and to the plate at each side of the opening with not less than eight 10d (0.148 inch diameter) having a minimum length of 1 ½ inches (38

mm) at each side or equivalent. Fasteners will be offset to prevent splitting of the top plate material. The metal tie must extend a minimum of 6 inches past the opening. See figure R602.6.1. {remainder unchanged}

Figure R602.6.1; delete the figure and insert the following figure:

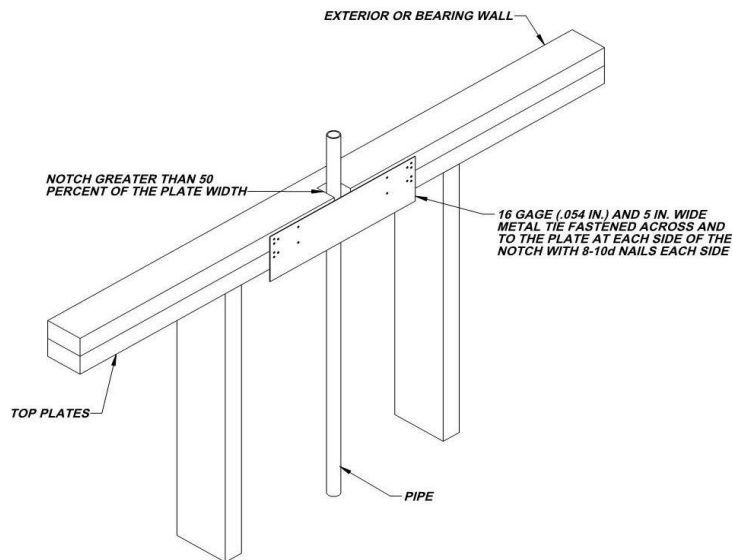

Add section R703.8.4.1.2 Veneer Ties for Wall Studs; to read as follows:

R703.8.4.1.2 Veneer Ties for Wall Studs. In stud framed exterior walls, all ties may be anchored to studs as follows:

1. When studs are 16 in (407 mm) o.c., stud ties shall be spaced no further apart than 24 in (737 mm) vertically starting approximately 12 in (381 mm) from the foundation; or
2. When studs are 24 in (610 mm) o.c., stud ties shall be spaced no further apart than 16 in (483 mm) vertically starting approximately 8 in (254 mm) from the foundation.

Section R902.1; amend and add exception #5 to read as follows:

R902.1 Roofing covering materials. Roofs shall be covered with materials as set forth in Sections R904 and R905. Class A, B, or C roofing shall be installed. ~~in designated by law as requiring their use or when the edge of the roof is less than 3 feet from a lot line.~~ {remainder unchanged}

Exceptions:

1. {text unchanged}
2. {text unchanged}
3. {text unchanged}
4. {text unchanged}
5. Non-classified roof coverings shall be permitted on one-story detached accessory structures used as tool and storage sheds, playhouses, and similar uses, provided the floor area does not exceed (area defined by jurisdiction).

Chapter 11 [RE] – Energy Efficiency is deleted in its entirety; Reference the 2018 IECC for energy code provisions and recommended amendments.

Section M1305.1.2; change to read as follows:

M1305.1.2 Appliances in attics. Attics containing appliances shall be provided . . . {bulk of paragraph unchanged} . . . side of the appliance. The clear access opening dimensions shall be a minimum of 20 inches by 30 inches (508 mm by 762 mm), and large enough to allow removal of the largest appliance. As a minimum, for access to the attic space, provide one of the following:

1. A permanent stair.
2. A pull down stair with a minimum 300 lb (136 kg) capacity.
3. An access door from an upper floor level.

Exceptions: [remaining text unchanged]

Section M1411.3; change to read as follows:

M1411.3 Condensate disposal. Condensate from all cooling coils or evaporators shall be conveyed from the drain pan outlet to an approved place of disposal a sanitary sewer through a trap, by means of a direct or indirect drain {remaining text unchanged}

Section M1411.3.1, Items 3 and 4; add text to read as follows:

M1411.3.1 Auxiliary and secondary drain systems. {bulk of paragraph unchanged}

1. *{text unchanged}*
2. *{text unchanged}*
3. An auxiliary drain pan... *{bulk of text unchanged}*... with Item 1 of this section. A water level detection device may be installed only with prior approval of the *building official*.
4. A water level detection device... *{bulk of text unchanged}*... overflow rim of such pan. A water level detection device may be installed only with prior approval of the *building official*.

Section M1411.3.1.1; add text to read as follows:

M1411.3.1.1 Water-level monitoring devices. On down-flow units ...*{bulk of text unchanged}*... installed in the drain line. A water level detection device may be installed only with prior approval of the *building official*.

M1503.6 Makeup Air Required; amend and add exception as follows:

M1503.6 Makeup air required. Where one or more gas, liquid or solid fuel-burning appliance that is neither direct-vent nor uses a mechanical draft venting system is located within a dwelling unit's air barrier, each exhaust system capable of exhausting in excess of 400 cubic feet per minute (0.19 m³/s) shall be mechanically or passively provided with makeup air at a rate approximately equal to the difference between exhaust air rate and 400 cubic feet per minute. Such makeup air systems shall be equipped with not fewer than one damper complying with [Section M1503.6.2](#).

Exception: Makeup air is not required for exhaust systems installed for the exclusive purpose of space cooling and intended to be operated only when windows or other air inlets are open. Where all appliances in the house are of sealed combustion, power-vent, unvented, or electric, the exhaust hood system shall be permitted to exhaust up to 600 cubic feet per minute (0.28 m³/s) without providing makeup air. Exhaust hood systems capable of exhausting in excess of 600 cubic feet per minute (0.28 m³/s) shall be provided with a makeup air at a rate approximately to the difference between the exhaust air rate and 600 cubic feet per minute.

Section M2005.2; change to read as follows:

M2005.2 Prohibited locations. Fuel-fired water heaters shall not be installed in a room used as a storage closet. Water heaters located in a bedroom or bathroom shall be installed in a sealed enclosure so that *combustion air* will not be taken from the living space. Access to such enclosure may be from the bedroom or bathroom when through a solid door, weather-stripped in accordance with the exterior door air leakage requirements of the *International Energy Conservation Code* and equipped with an *approved self-closing device*. Installation of direct-vent water heaters within an enclosure is not required.

Section G2408.3 (305.5)Private Garages; delete this section in its entirety.

Section G2415.2 (404.2) CSST; add a second paragraph to read as follows:

Both ends of each section of medium pressure gas piping shall identify its operating gas pressure with an approved tag. The tags are to be composed of aluminum or stainless steel and the following wording shall be stamped into the tag:

"WARNING: 1/2 to 5 psi gas pressure - Do Not Remove"

Section G2415.12 (404.12) and G2415.12.1 (404.12.1); change to read as follows:

G2415.12 (404.12) Minimum burial depth. Underground *pipng systems* shall be installed a minimum depth of ~~12 inches (305 mm)~~ 18 inches (457 mm) below grade, ~~except as provided for in Section G2415.12.1.~~

G2415.12.1 (404.12.1) Individual Outdoor Appliances; Delete in its entirety

Section G2417.1 (406.1); change to read as follows:

G2417.1 (406.1) General. Prior to acceptance and initial operation, all *pipng* installations shall be inspected and *pressure tested* to determine that the materials, design, fabrication, and installation practices comply with the requirements of this *code*. The *permit* holder shall make the applicable tests prescribed in Sections 2417.1.1 through 2417.1.5 to determine compliance with the provisions of this *code*. The *permit* holder shall give reasonable advance notice to the *building official* when the *pipng system* is ready for testing. The *equipment*, material, power and labor necessary for the inspections and test shall be furnished by the *permit* holder and the *permit* holder shall be responsible for determining that the work will withstand the test pressure prescribed in the following tests.

Section G2417.4; change to read as follows:

G2417.4 (406.4) Test pressure measurement. Test pressure shall be measured with a monometer or with a pressure-measuring device designed and calibrated to read, record, or indicate a pressure loss caused by leakage during the pressure test period. The source of pressure shall be isolated before the pressure tests are made. ~~Mechanical gauges used to measure test pressures shall have a range such that the~~

highest end of the scale is not greater than five times the test pressure.

Section G2417.4.1; change to read as follows:

G2417.4.1 (406.4.1) Test pressure. The test pressure to be used shall be no less than 3 psig (20 kPa gauge), or at the discretion of the Code Official, the piping and valves may be tested at a pressure of at least six (6) inches (152 mm) of mercury, measured with a manometer or slope gauge, irrespective of design pressure. Where the test pressure exceeds 125 psig (862 kPa gauge), the test pressure shall not exceed a value that produces a hoop stress in the piping greater than 50 percent of the specified minimum yield strength of the pipe. For tests requiring a pressure of 3 psig, diaphragm gauges shall utilize a dial with a minimum diameter of three and one half inches (3 ½”), a set hand, 1/10 pound incrementation and pressure range not to exceed 6 psi for tests requiring a pressure of 3 psig. For tests requiring a pressure of 10 psig, diaphragm gauges shall utilize a dial with a minimum diameter of three and one-half inches (3 ½”), a set hand, a minimum of 2/10 pound incrementation and a pressure range not to exceed 20 psi. For welded piping, and for piping carrying gas at pressures in excess of fourteen (14) inches water column pressure (3.48 kPa) (1/2 psi) and less than 200 inches of water column pressure (52.2 kPa) (7.5 psi), the test pressure shall not be less than ten (10) pounds per square inch (69.6 kPa). For piping carrying gas at a pressure that exceeds 200 inches of water column (52.2 kPa) (7.5 psi), the test pressure shall be not less than one and one-half times the proposed maximum working pressure.

Diaphragm gauges used for testing must display a current calibration and be in good working condition. The appropriate test must be applied to the diaphragm gauge used for testing.

Section G2417.4.2; change to read as follows:

G2417.4.2 (406.4.2) Test duration. The test duration shall be held for a length of time satisfactory to the Building Official, but in no case for ~~be not~~ less than ~~10~~ fifteen (15) minutes. For welded piping, and for piping carrying gas at pressures in excess of fourteen (14) inches water column pressure (3.48 kPa), the test duration shall be held for a length of time satisfactory to the Building Official, but in no case for less than thirty (30) minutes.

Section G2420.1 (406.1); add Section G2420.1.4 to read as follows:

G2420.1.4 Valves in CSST installations. Shutoff valves installed with corrugated stainless steel (CSST) piping systems shall be supported with an approved termination fitting, or equivalent support, suitable for the size of the valves, of adequate strength and quality, and located at intervals so as to prevent or damp out excessive vibration but in no case greater than 12-inches from the center of the valve. Supports shall be installed so as not to interfere with the free expansion and contraction of the system's piping, fittings, and valves between anchors. All valves and supports shall be designed and installed so they will not be disengaged by movement of the supporting piping.

Section G2420.5.1 (409.5.1); add text to read as follows:

G2420.5.1 (409.5.1) Located within the same room. The shutoff valve...*{bulk of paragraph unchanged}*... in accordance with the appliance manufacturer's instructions. A secondary shutoff valve must be installed within 3 feet (914 mm) of the firebox if appliance shutoff is located in the firebox.

Section G2421.1 (410.1); add text and Exception to read as follows:

G2421.1 (410.1) Pressure regulators. A line *pressure regulator* shall be ... *{bulk of paragraph unchanged}*... *approved* for outdoor installation. Access to *regulators* shall comply with the requirements for access to *appliances* as specified in Section M1305.

Exception: A passageway or level service space is not required when the *regulator* is capable of being serviced and removed through the required *attic* opening.

Section G2422.1.2.3 (411.1.3.3) Prohibited locations and penetrations; delete Exception 1 and Exception 4.

Section G2445.2 (621.2); add Exception to read as follows:

G2445.2 (621.2) Prohibited use. One or more *unvented room heaters* shall not be used as the sole source of comfort heating in a *dwelling unit*.

Exception: Existing *approved unvented room heaters* may continue to be used in *dwelling units*, in accordance with the *code* provisions in effect when installed, when *approved* by the *Building Official* unless an unsafe condition is determined to exist as described in *International Fuel Gas Code Section 108.7* of the Fuel Gas Code.

Section G2448.1.1 (624.1.1); change to read as follows:

G2448.1.1 (624.1.1) Installation requirements. The requirements for *water heaters* relative to access, sizing, *relief valves*, drain pans and scald protection shall be in accordance with this *code*.

Section P2603; add to read as follows:

P2603.3 Protection against corrosion. Metallic piping, except for cast iron, ductile iron and galvanized steel, shall not be placed in direct contact with steel framing members, concrete or cinder walls and floors or other masonry. Metallic piping shall not be placed in direct contact with corrosive soil. Where sheathing is used to prevent direct contact, the sheathing shall have a thickness of not less than 0.008 inch (8 mil) (0.203 mm) and the sheathing shall be made of approved material plastic. Where sheathing protects piping that penetrates concrete or masonry walls or floors, the sheathing shall be installed in a manner that allows movement of the piping within the sheathing.

Section P2603.5.1 Sewer Depth; change to read as follows:

P2603.5.1 Sewer depth. Building sewers that connect to private sewage disposal systems shall be a minimum of [number] inches (mm) below finished grade at the point of septic tank connection. Building sewers shall be a minimum of 12 inches (304 mm) below grade.

Section P2604; add to read as follows:

P2604.2.1 Plastic sewer and DWV piping installation. Plastic sewer and DWV piping installed underground shall be installed in accordance with the manufacturer's installation instructions. Trench width shall be controlled to not exceed the outside the pipe diameter plus 16 inches or in a trench which has a controlled width equal to the nominal diameter of the piping multiplied by 1.25 plus 12 inches. The piping shall be bedded in 4 inches of granular fill and then backfilled compacting the side fill in 6-inch layers on each side of the piping. The compaction shall be to minimum of 85 percent standard proctor density and extend to a minimum of 6 inches above the top of the pipe.

Section P2801; change to read as follows:

P2801.6 Required pan.

Where a storage tank-type water heater or a hot water storage tank is installed in a location where water leakage from the tank will cause damage, the tank shall be installed in a pan constructed of one of the following:

1. Galvanized steel or aluminum of not less than 0.0236 inch (0.6010 mm) in thickness.
2. Plastic not less than 0.036 inch (0.9 mm) in thickness.
3. Other *approved* materials.

~~A plastic pan beneath a gas-fired water heater shall be constructed of material having a flame spread index of 25 or less and a smoke-developed index of 450 or less when tested in accordance with ASTM E84 or UL 723.~~

Section P2801.6.1; change to read as follows:

Section P2801.6.1 Pan size and drain. The pan shall be not less than 11/2 inches (38 mm) in depth and shall be of sufficient size and shape to receive all dripping or condensate from the tank or water heater. The pan shall be drained by an indirect waste pipe having a diameter of not less than 3/4 inch (19 mm). Piping for safety pan drains shall be of those materials listed in Table P2906.5.

Multiple pan drains may terminate to a single discharge piping system when approved by the administrative authority and permitted by the manufactures installation instructions and installed with those instructions. {existing text unchanged}

Section P2804.6.1; change to read as follows:

Section P2804.6.1 Requirements for discharge piping. The discharge piping serving a pressure relief valve, temperature relief valve or combination thereof shall:

1. Not be directly connected to the drainage system.
2. Discharge through an air gap ~~located in the same room as the water heater.~~
3. Not be smaller than the diameter of the outlet of the valve served and shall discharge full size to the air gap.
4. Serve a single relief device and shall not connect to piping serving any other relief device or equipment.

Exception: Multiple relief devices may be installed to a single T & P discharge piping system when approved by the administrative authority and permitted by the manufactures installation instructions and installed with those instructions.

5. Discharge to ~~the floor, to the pan serving the water heater or storage tank, to a waste receptor~~ an approved location or to the outdoors.

[remainder unchanged]

Section P2902.5.3; change to read as follows:

P2902.5.3 Lawn irrigation systems. The potable water supply to lawn irrigation systems shall be protected against backflow by an atmospheric-type vacuum breaker, a pressure-type vacuum breaker, a double-check assembly or a reduced pressure principle backflow preventer. A valve shall not be installed downstream from an atmospheric vacuum breaker. Where chemicals are introduced into the system, the potable water supply shall be protected against backflow by a reduced pressure principle backflow preventer.

Section P3003.9; change to read as follows:

P3003.9.2 Solvent cementing. Joint surfaces shall be clean and free from moisture. A purple primer that conforms to ASTM F 656 shall be applied. Solvent cement not purple in color and conforming to ASTM D 2564, CSA B137.3, CSA B181.2 or CSA B182.1 shall be applied to all joint surfaces. The joint shall be made while the cement is wet and shall be in accordance with ASTM D 2855. Solvent cement joints shall be permitted above or below ground.

Section P3003.9; change to read as follows:

P3003.9.2 Solvent cementing. Joint surfaces shall be clean and free from moisture. A purple primer that conforms to ASTM F 656 shall be applied. Solvent cement not purple in color and conforming to ASTM D 2564, CSA B137.3, CSA B181.2 or CSA B182.1 shall be applied to all joint surfaces. The joint shall be made while the cement is wet and shall be in accordance with ASTM D 2855. Solvent cement joints shall be permitted above or below ground.

~~Exception: A primer is not required where both of the following conditions apply:~~

- ~~1. The solvent cement used is third party certified as conforming to ASTM D 2564~~
- ~~2. The solvent cement is used only for joining PVC drain, waste, and vent pipe and fittings in not pressure applications in sizes up to and including 4 inches (102mm) in diameter.~~

Section P3111Combination waste and vent systems; delete this section in its entirety.

Section P3112.2 Vent Connection; delete and replace with the following:

P3112.2 Installation. Traps for island sinks and similar equipment shall be roughed in above the floor and may be vented by extending the vent as high as possible, but not less than the drainboard height and then returning it downward and connecting it to the horizontal sink drain immediately downstream from the vertical fixture drain. The return vent shall be connected to the horizontal drain through a wye-branch fitting and shall, in addition, be provided with a foot vent taken off the vertical fixture vent by means of a wye-branch immediately below the floor and extending to the nearest partition and then through the roof to the open air or may be connected to other vents at a point not less than six (6) inches (152 mm) above the flood level rim of the fixtures served. Drainage fittings shall be used on all parts of the vent below the floor level and a minimum slope of one-quarter (1/4) inch per foot (20.9 mm/m) back to the drain shall be maintained. The return bend used under the drain-board shall be a one (1) piece fitting or an assembly of a forty-five (45) degree (0.79 radius), a ninety (90) degree (1.6 radius) and a forty-five (45) degree (0.79 radius) elbow in the order named. Pipe sizing shall be as elsewhere required in this Code. The island sink

drain, upstream of the return vent, shall serve no other fixtures. An accessible cleanout shall be installed in the vertical portion of the foot vent.

Sec. 4-135. - Specific Amendments to the 2021 International Fire Code.

Sec. 4-135. Specific Amendments to the 2021 International Fire Code.

The following sections of the 2021 Edition of the International Fire Code including Appendices B, C, D, E, F, G, H, I, J, K, L, N and the provisions of which shall be controlling within the limits of the City of Keller, are hereby amended for the purpose of consistency with specific past practices and the recommendations of the North Central Texas Council of Governments Fire Advisory Board.

General Terms

- (1) Code official or fire code official. The fire chief or designee, Fire Marshal or designee, or member of the fire department, charged with the duties of administration and enforcement of this code, or a duly authorized representative.
- (2) Jurisdiction. All references to “jurisdiction” shall mean the City of Keller, Tarrant County Texas.
- (3) Chief. All references to “Chief of the Bureau of Fire Prevention” shall be replaced with Fire Marshal.”
- (4) Fire Marshal. All references to “Fire Marshal” shall include the Fire Marshal’s designee.

Section 101.1 shall be amended to read as follows:

101.1 Title. These regulations shall be known as the fire code of the City of Keller, hereinafter referred to as “this Code.”

Section 102.1 shall be amended to read as follows:

102.1 Construction and design provisions is amended by changing 102.1 #3 and adding 102.1.1 to read as follows:

Section 102.1 #3 Existing structures, facilities, and conditions when required in Chapter 11 or in specific sections of this code.

Section 102.1.1 Reconstruction and Remodel. An existing building that has changed ownership, use or occupancy classification, is being altered or remodeled, shall comply with currently adopted fire code as it relates to:

- (1) Panic hardware
- (2) Fire alarms
- (3) Fire sprinkler systems
- (4) Exit lights

- (5) Emergency lighting
- (6) Exits and exit ways

Section 102.7 is deleted in its entirety and replaced with Section 102.7.3 below.

Section 102.7.2 shall be amended to read as follows:

102.7.2 Provisions in referenced codes and standards. Where the extent of the reference to a referenced code or standard includes subject matter that is within the scope of this code and any adopted amendments, the provisions of this code and any adopted amendments, as applicable, shall take precedence over the provisions in the referenced code or standard.

Section 102.7.3 shall be added to read as follows:

102.7.3 The most currently published Editions of NFPA shall be the Referenced Codes adopted. Specific reference is made for the adoption of NFPA 3: Standard for Commissioning of Fire Protection Life Safety Systems and NFPA 17A including all associated appendices, specifically Appendix B and NFPA 96: Standard for Ventilation Control and Fire Protection of Commercial Cooking Operations and Appendix B of NFPA 96. Any reference to NFPA 70 or the ICC Electrical Code shall mean the National Electrical Code, as adopted.

Section 104.12 shall be added to read as follows:

104.12 Governmental Immunity. The Fire Prevention Division is exercised by the City of Keller of its governmental functions, for the protection of the public peace, health and safety; and neither the City nor agents and representatives of said City (or any individual, receiver, firm, partnership, corporation, association, trustee or any of the agents thereof, in good faith carrying out, complying with or attempting to comply with any order, rule or regulation promulgated pursuant to the provisions of this Ordinance) shall be liable for any damage sustained to persons or property as the result of said activity.

Section 105.1 amend to read as follows:

Section 105.1 Permits. Permits shall be required as set forth in Section 105.1.1 through Section 105.7.25 in their entirety and as required by this section. A permit shall be required for the installation, reconsideration, modification, moving or alteration of any life safety system including but not limited to fire sprinkler systems, fire alarm systems, fixed extinguishing systems, access control systems and carbon dioxide sensing and monitoring systems, hazardous materials and cryogenic fluids. Work shall not begin on any system without first obtaining a permit. Any person, firm, or corporation who that violates this requirement shall be liable for a fine that is two-times the cost of the Permit or two-hundred Dollars (\$250.00), whichever is greater.

Exemption: Emergency repairs, due to system malfunctions or discharging, may begin, providing a permit is obtained as soon as possible, but no later than the next business day.

Section 105.1.1; change to read as follows:

Section 105.1.1 The state licensed agent who intends install or modify systems and equipment that are regulated by this code, or to cause any such work to be performed, shall first make application to the fire code official and obtain the required permit.

Section 105.3.3; change to read as follows:

Section 105.3.3 Occupancy Prohibited before Approval. The building or structure shall not be occupied prior to the fire code official approving a permit application and conducting the associated inspections indicating the applicable provisions of this code have been met. Occupancy without approval may result in the fire code official placing a “DO NOT ENTER BY ORDER OF THE FIRE MARSHAL” notice on building/suite.

Section 105.5.12 Cutting and welding. Shall be amended as follows:

Section 105.5.12 Cutting and welding. An operational permit is required to conduct cutting and welding operations within the jurisdiction, this includes the use of Oxy-Acetylene cutting torches.

Section 105.5.32 shall be amended as follows:

105.5.32 Mobile food preparation vehicles. A permit is required for all mobile food vehicles and vendors.

Section 105.5.34 shall be amended as follows:

Section 105.5.34 Open Burning. Open Burning is prohibited in the City of Keller. See Section 307.2 of this Code.

Section 105.6.25; add to read as follows:

105.6.25 Electronic access control systems. Construction permits are required to install or modify an electronic access control system, as specified in Chapter 10. A separate construction permit is required to install or modify a fire alarm system that may be connected to the access control system. Maintenance performed in accordance with this code is not considered a modification and does not require a permit.

Section 105.6.26 shall be added to read as follows:

105.6.26 Model Rocketry. An operational permit is required for the demonstration and use of model rockets, in accordance with NFPA 1122.

Section 105.6.27 Fire Fighter Air Replenishment System. shall be added to read as follows:

105.6.27 Fire Fighter Air Replenishment System An operational permit is required to maintain a FARS.

Section 105.7 is hereby amended by adding section 105.7.26 to read as follows:

105.7.26 Fire Fighter Air Replenishment System. A construction permit is required for installation of or modification to a FARS. The construction permit application shall include documentation of an acceptance and testing plan as specified in Section L105.

Section 107.3 shall be amended to read as follows:

107.3 Permit valuations. The applicant for a permit shall provide a copy of the signed contract for their scope of work at the time of application. Permit valuations shall include the total value of work, including materials and labor for which the permit is being issued.

Section 107.4 shall be amended as follows:

107.4 Work commencing before permit issuance. Any person, firm, partnership, corporation, association, or other entity who commences any work, activity or operation regulated by this code before obtaining the necessary permits shall be fined a minimum of \$250.00 or double the permit fee, whichever is greater. Each day work continues shall constitute a separate and distinct violation.

Section 109.3 Recordkeeping. Add a third paragraph to read as follows:

All Fire and Life Safety test and inspection records shall be filed via Compliance Center at www.buildingreports.com Sign-up at www.BuildingReports.com/signup Buildings with the following fire protection systems in place shall have test results recorded electronically: Fire Alarm, Fire Sprinkler, Fixed Suppression, Fire Pump, Fire Line Backflow, CO², and Elevators.

Section 112.3; change to read as follows:

Section 112.3 Notice of Violation; Where the fire code official finds a building, premises, vehicle, storage facility or outdoor area that is in violation of this code, the fire code official is authorized to prepare a written notice of violation describing the conditions deemed unsafe and, where compliance is not immediate, specifying a time for re-inspection. The fire code official is authorized to issue citations alleging violations of this code for prosecution in the Municipal Court. Notice under this section is not a prerequisite to prosecution of violations of this code.

Section 112.4 Violation penalties. Shall be amended to read as follows:

Persons who shall violate a provision of this code, or shall fail to comply with any of the requirements, thereof, or who shall erect, install, alter, repair, or do work in violation of the *approved construction documents*, or directive, of the *fire code official*, or of a permit, or a certificate, used under provisions of this code, shall be fined a minimum of \$250.00 or double the permit fee, whichever is greater. Each day that a violation continues after due notice has been served, shall be deemed a separate offense.

Section 112.4.2 shall be added to read as follows:

112.4.2 Citations. It is the intent of this division to achieve compliance by the traditional means of inspection, notification, granting of reasonable time to comply and re-inspection. After all reasonable means to gain compliance have failed, or when a condition exists that causes an immediate and/or extreme threat to life, property or safety from fire or explosion, the Fire Chief or his designee, who have the discretionary duty to enforce a code or ordinance may issue a notice to appear (citation) for the violation. Citations shall be issued only by qualified personnel as designated by the Fire Chief.

Notwithstanding any other provision of this code or of the International Fire Code, a citation may be issued without prior notice and the opportunity to correct the condition or violation if the violation is determined to be an immediate threat to life safety.

Section 112.4.3 shall be added to read as follows:

112.4.3 Compliance with codes. Any person or entity that violates, disobeys, omits, neglects, or refuses to comply with, or who resists the enforcement of the provisions of this or other codes as referenced in this ordinance, shall be guilty of a misdemeanor and subject to the penalties as set forth in the Code of Ordinances of the City. In addition to these penalties the fire code official or his or her designee is authorized to close any business, or shut down any operation when any hazard or condition exists therein that poses a serious and imminent threat to life or property. Any reasonable method may be used to affect closure, including, but not limited to, disconnection of utilities and padlocking of any doors. Any person in control of or occupying any premises ordered closed, or performing or overseeing any operation ordered discontinued, who refuses an order to leave, or to discontinue is guilty of a misdemeanor and subject to the penalties described herein.

Section 113.4 shall be amended to read as follows:

113.4 Failure to comply. Any person, firm, or corporation who shall continue any work after having been served with a stop work order, except such work as that person, firm, or corporation is directed to perform to remove a violation or unsafe condition, or entry to the building after notice is posted, shall be fined not less than Five Hundred Dollars (\$500.00) or more than Two Thousand Dollars (\$2,000.00).

Section 202 DEFINITIONS. Shall be amended by adding new definitions to the existing list of definitions in Section 202 of the 2021 International Fire Code, to read as follows:

ADDRESSABLE FIRE DETECTION SYSTEM. Any system capable of providing identification of each individual alarm-initiating device. The identification shall be in plain English and as descriptive as possible to specifically identify the location of the device in alarm. The system shall have the capability of alarm verification.

ANALOG INTELLIGENT ADDRESSABLE FIRE DETECTION SYSTEM. Any system capable of calculating a change in value by directly measurable quantities (voltage, resistance, etc.) at the sensing point. The physical analog may be conducted at the sensing point or at the main control panel. The system shall be capable of compensating for long-term changes in sensor response while maintaining a constant sensitivity. The compensation shall have a preset point at which a detector maintenance signal shall be transmitted to the control panel. The sensor shall remain capable of detecting and transmitting an alarm while in maintenance alert.

AMBULATORY CARE FACILITY. . Buildings or portions thereof used to provide medical, surgical, psychiatric, nursing, or similar care on a less than 24-hour basis to persons who are rendered incapable of self-preservation by the services provided or staff has accepted responsibility for care recipients already incapable. This group may include but not be limited to the following:

- Dialysis centers
- Procedures involving sedation
- Sedation dentistry
- Surgery centers
- Colonic centers
- Psychiatric centers

ATRIUM. An opening connecting three or more stories... {Remaining text unchanged}

CHANGE OF OCCUPANCY. Any of the following shall be considered a change of occupancy where this code requires a greater degree of safety, accessibility, structural strength, fire protection, means of egress, ventilation or sanitation than is existing in the current building or structure:

1. Any change in the occupancy classification of a building or structure.
2. Any change in the purpose of, or a change in the level of activity within, a building or structure.
3. Any change of ownership of a business, building or structure.

DEFEND IN PLACE. A method of emergency response that engages building components and trained staff to provide occupant safety during an emergency. Emergency response involves remaining in place, relocating within the building, or both, without evacuating the building.

ELECTRICAL CODE. Electrical Code shall mean NFPA 70, the National Electrical Code, as adopted by this jurisdiction. For the purpose of this code, all references to NFPA 70 and/or the ICC Electrical Code shall be assumed to mean the Electrical Code as defined herein.

EMERGENCY ACCESS EASEMENT. An access road or fire lane located on private property dedicated by the owner(s) of the property to provide fire apparatus access.

FIRE ALARM SYSTEM. A system or portion of a combination system consisting of components and circuits arranged to monitor and annunciate the status of a fire alarm or supervisory signal-

initiating devices and to initiate the appropriate response to those signals. A fire alarm system shall include but is not limited to the following:

- Manual pull stations at all required exits
- Occupant notification throughout the entire building
- Systems installed to monitor a fire sprinkler system shall also be considered a Fire Alarm System

FIRE AREA. The aggregate floor area enclosed and bounded by firewalls, fire barriers, exterior walls or horizontal assemblies of a building. Areas of the building not provided with surrounding walls shall be included in the fire area if such areas are included within the horizontal projection of the roof or floor above. For purposes of determining automatic sprinkler systems required by Section 903, a fire area shall be determined by the aggregate floor area enclosed and bounded by the exterior walls of a building and/or the horizontal projection of the roof.

FIRE WATCH. A temporary measure intended to ensure continuous and systematic surveillance of a building or portion thereof by one or more qualified individuals or standby personnel when required by the fire code official, for the purposes of identifying and controlling fire hazards, detecting early signs of unwanted fire, raising an alarm of fire and notifying the fire department. The owner or owners representative shall hire a private security firm to supply personnel to monitor for fire conditions and have the means necessary for contacting 911 immediately when required by the 2021 IFC Sections 403.11.1, 901.7, 3107.17, 3305.5, 3305.5.1, 3305.5.2, 3305.5.3, and 3504.2.2.

FIREWORKS. Any composition or device for the purpose of producing a visible or an audible effect for entertainment purposes by combustion, deflagration, detonation, and/or activated by ignition with a match or other heat producing device that meets the definition of 1.4G fireworks or 1.3G fireworks as set forth herein

HIGH-PILED COMBUSTIBLE STORAGE: add a second paragraph to read as follows:

Any building classified as a group S Occupancy or Speculative Building exceeding 6,000 sq. ft. that has a clear height in excess of 14 feet, making it possible to be used for storage in excess of 12 feet, shall be considered high-piled storage. When a specific product cannot be identified, a fire protection system and life safety features shall be installed as for Class IV commodities, to the maximum pile height.

HIGH-RISE BUILDING. A building with an occupied floor located more than 55 feet (16,764 mm) above the lowest level of fire department vehicle access.

REPAIR GARAGE. A building, structure or portion thereof used for servicing or repairing motor vehicles. This occupancy shall also include garages involved in minor repair, modification and servicing of motor vehicles for items such as lube changes, inspections, windshield repair or replacement, shocks, minor part replacement, and other such minor repairs.

SERVICE STORAGE FACILITY. Real property designed and used for the purpose of renting or leasing individual storage spaces to customers for the purpose of storing and removing personal property on a self-service basis.

STANDBY PERSONNEL. Qualified fire service personnel, approved by the Fire Chief. When utilized, the number required shall be as directed by the Fire Chief. Charges for utilization shall be as normally calculated by the jurisdiction.

UPGRADED OR REPLACED FIRE ALARM SYSTEM. A fire alarm system that is upgraded or replaced includes, but is not limited to the following:

- Replacing one single board or fire alarm control unit component with a newer model
- Installing a new fire alarm control unit in addition to or in place of an existing one
- Conversion from a horn system to an emergency voice/alarm communication system
- Conversion from a conventional system to one that utilizes addressable or analog devices

The following are not considered an upgrade or replacement:

- Firmware updates
- Software updates

Section 307.1 General shall be amended to read as follows:

307.1. All open burning, including land clearing operations, prescribed burns and burning of domestic waste is prohibited by **City of Keller Ordinance No. 1807.**

Section 308.1.4 shall be amended to read as follows:

Section 308.1.4 Open-flame cooking devices. Open-flame cooking devices, charcoal grills and other similar devices used for cooking shall not be located or used on combustible balconies, decks, or within 10 feet (3048 mm) of any combustible construction.

Exceptions:

1. One- and two-family dwellings, except that LP-gas containers are limited to a water capacity no greater than 50 pounds (22.68 kg) [nominal 20-pound (9.08 kg) LP-gas capacity] with an aggregate LP-gas capacity not to exceed 100 pounds (5 containers). All LP-gas containers shall be stored outside, per Chapter 61.

2. Where buildings, balconies and decks are protected by an approved automatic sprinkler system, except that LP-gas containers are limited to a water capacity no greater than 50 pounds (22.68 kg) [nominal 20-pound (9.08 kg) LP-gas capacity] with an aggregate LP-gas capacity not to exceed 40 pounds (2 containers). All LP-gas containers shall be stored outside, per Chapter 61.
3. LP-gas cooking devices having LP-gas containers with water capacity not greater than 2-½ pounds [nominal 1-pound (0.454 kg) LP-gas capacity].

Section 308.1.6.2, Exception 3 shall be amended to read as follows:

3. Torches or flame-producing devices in accordance with Section 308.1.3.

Section 308.1.6.3 shall be amended to read as follows.

308.1.6.3 Sky Lanterns. A person shall not release or cause to be released an unmanned free-floating device containing an open flame or other heat source, such as, but not limited to a sky lantern.

Section 308 Open Flames is amended by adding Section 308.5 and subsections to read as follows:

Section 308.5 Open Flame Cooking

The use of open flame cooking devices shall be as follows:

Section 308.5.1. Multifamily structure.

It shall be a violation of this code for any person to use, allow or permit the use of a fixed or portable grill or cooking device that uses an open flame or electrical heating element within ten (10) feet of any multi-family structure, under any covered portion of a multi-family structure, under any covered parking structure or portion thereof.

Section 308.5.2 Sign.

It shall be a violation of this code for any person to own or manage any multi-family structure without installing and maintaining on each balcony, patio, landing or similar structure of each dwelling unit an approved sign readily visible to the occupants that prohibits the use of any grill, hibachi, smoker, electrical heating element, or similar apparatus within ten (10) feet of all apartment structures. Signs shall be at least thirty (30) square inches with the word "PROHIBITED" in one (1) inch letter, and the remaining message in at least one-fourth (1/4) inch letter, red on white, and provide the following warning:

-PROHIBITED- THE USE OF ANY GRILL, HIBACHI, OR SMOKER IN OR WITHIN TEN FEET OF ALL APARTMENT STRUCTURES, PATIOS AND CARPORTS. KELLER FIRE CODE - FINE UP TO \$2000.00

Section 311.5; change to read as follows:

Section 311.5 Placards. The fire code official is authorized to require marking of any vacant or abandoned buildings or structures determined to be unsafe pursuant to Section 110 of this code relating to structural or interior hazards, as required by Section 311.5.1 through 311.5.5.

Section 319 Mobile Food Preparation Vehicles

Section 319.1; change to read as follows:

Section 319.1 General. All mobile food vehicles shall comply with this section.

Section 403.5; change Section 403.5 to read as follows:

Section 403.5 Group E Occupancies. An approved fire safety and evacuation plan in accordance with Section 404 shall be prepared and maintained for Group E occupancies and for buildings containing both a Group E occupancy and an atrium. A diagram depicting two evacuation routes shall be posted in a conspicuous location in each classroom. Group E occupancies shall also comply with Sections 403.4.1 through 403.4.3.

Section 404.2.2 Fire Safety Plans add number 4.10 to read as follows:

Section 4.10 Fire extinguishing system controls.

Section 405.5 Time; change to read as follows:

Section 405.5 Time. The fire code official may require an evacuation drill at any time. Drills shall be held at unexpected times and under varying conditions to simulate the unusual conditions that occur in case of fire.

Section 501.4 Timing of Installation; change to read as follows:

Section 501.4 Timing of Installation. Where fire apparatus access roads or a water supply for fire protection is required to be installed for any structure or development, they shall be installed, tested, and approved prior to the time of which construction has progressed beyond completion of the foundation of any structure and before vertical construction with combustible material has begun.

Section 503.1.1 Buildings and Facilities; shall be amended to add the following paragraph:

Except for one- or two-family dwellings, the path of measurement shall be along a minimum of a ten foot (10') wide unobstructed level pathway around the external walls of the structure.

Section 503.2.1 amend to read as follows:

503.2.1 Dimensions. Fire apparatus access roads shall have an unobstructed width of not less than 24 feet (7,315 mm), exclusive of shoulders, except for approved security gates in accordance with Section 503.6, and an unobstructed vertical clearance of not less than sixteen (16) feet.

Section 503.2.2; change to read as follows:

Section 503.2.2 Authority. The fire code official shall have the authority to require an increase in the minimum access widths and vertical clearances where they are inadequate for fire or rescue operations.

Section 503.2.3; change Section 503.2.3 to read as follows:

503.2.3 Surface. Construction of all fire lanes shall be in accordance with the Keller Unified Development Code Design and Construction Standards and this section.

Fire lanes shall be constructed of a concrete surface capable of supporting the imposed loads of a 2-axle, 85,000 lb. fire apparatus to provide all-weather driving capabilities. The design shall be based on the geotechnical investigation of the site, but shall meet the stated minimums.

All fire lanes shall be maintained and kept in a good state of repair at all times by the owner and the City of Keller shall not be responsible for the maintenance thereof. It shall further be the responsibility of the owner to insure that all fire lane markings required by Section 503.3 are maintained to ensure that they are easily distinguishable by the public.

Section 503.2.4 Turning radius shall be amended as follows:

503.2.4 Turning radius. The required turning radius of a fire apparatus access road shall be in accordance with this section.

Any such fire lane shall either connect both ends to a dedicated public street or fire lane or be provided with an approved turnaround having a minimum outer radius of fifty-four feet (54') and an inside radius of thirty feet (30').

Fire lane dimensions established by Appendix D, or other sections of this Code, shall be superseded by the criteria established by this section.

Section 503.2.7 shall be amended as follows:

503.2.7 Grade. The grade of the fire apparatus access road shall be within the limits established by the fire code official. In no case shall the grades along a fire apparatus access road exceed the following:

Along the Fire Apparatus Access Road – 6%

Cross Slope – 5%

Exception. The code official shall have the authority to adjust the grade along the fire lane when necessary for fire or rescue operations or based upon the hazard being protected or general topography of the lot. In no case shall the grade exceed seven percent (7%). Written approval from the fire code official shall be required.

Section 503.2.8 shall be amended to read as follows:

503.2.8 Angles of approach and departure. The angles of approach and departure for a fire apparatus access road shall be within the limits established by the fire code official. In no case shall the grades exceed the following:

1. Maximum Angle of Approach – 5%
2. Maximum Angle of Departure – 5%

Exception. The code official shall have the authority to adjust the grade along the fire lane when necessary for fire or rescue operations or based upon the hazard being protected or general topography of the lot. Written approval from the fire code official shall be required.

Section 503.3 shall be amended to read as follows:

503.3 Marking. Striping, signs, or other markings, when approved by the fire code official, shall be provided for fire apparatus access roads to identify such roads or prohibit the obstruction thereof. Striping, signs and other markings shall be maintained in a clean and legible condition at all times and shall be replaced or repaired when necessary to provide adequate visibility. Speed-reducing devices that are installed across Fire Department access roads and fire lanes shall be installed and maintained in accordance with the provisions of these rules and regulations. The speed-reducing devices shall be the **speed cushion type**.

1. **Striping** – painted lines of red traffic paint shall continuously mark Fire apparatus access roads six inches (6”) in width to show the boundaries of the lane. The words “NO PARKING FIRE LANE- TOW AWAY” or “FIRE LANE NO PARKING – TOW AWAY” shall appear in four inch (4”) white letters at 25 foot (25’) intervals on the red border markings along both sides of the fire lanes. Where a curb is available, the striping shall be on both the horizontal and vertical faces of the curb. The red paint shall meet the Texas Department of Highway and Public Transportation, (TXDOT), specification number TTP-115, chlorinated rubber paint or approved equal.

2. **Signs** – Signs shall read, “NO PARKING FIRE LANE – TOW AWAY” or “FIRE LANE NO PARKING TOW AWAY” and shall be twelve inches (12”) wide and eighteen inches (18”) high. Signs shall be painted on a white background with letters and borders in red, using not less than two-inch (2”) lettering. Signs shall be permanently affixed to a stationary post and the bottom of the sign shall be six feet, six inches (6’ 6”) above finished grade. Signs shall be spaced not more than fifty feet (50’) apart. Signs may be installed on permanent buildings or walls or as approved by the Fire Code Official.



Where the curb is available, the striping shall be on both the horizontal and vertical faces of the curb



Section 503.4 shall be amended to read as follows:

503.4 Obstruction of fire apparatus access roads. Fire apparatus access roads shall not be obstructed in any manner, including the parking of vehicles. The minimum widths and clearances established in Section 503.2.1 through 503.2.8 and any area marked, as a fire lane as described in Section 503.3 shall be maintained clear of obstructions at all times. Unattended vehicles or other obstructions in the fire lane may be removed or towed at the expense of the registered owner.

Section 503.4.1 Traffic Calming Devices. shall be amended as follows:

Section 503.4.1 Speed Cushions across fire apparatus access roads shall meet the design requirements specified in the Keller Unified Development Code as noted below:

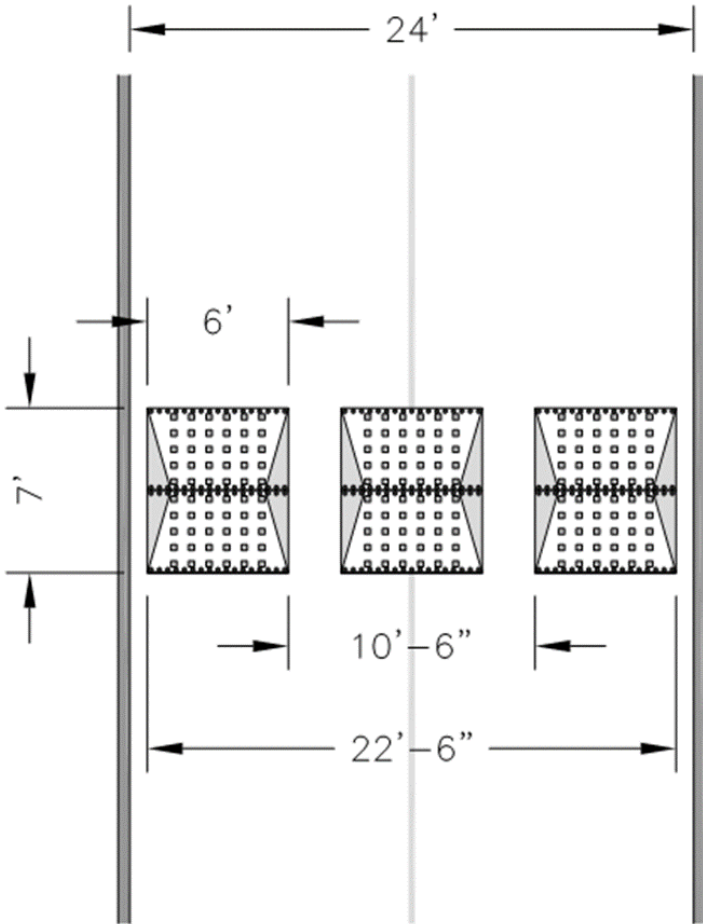

1. Dimensions 3"x6'x7'
2. Entrance and Exit Gradient: 1:15
3. Side Gradient: 1:3
4. Material: Compression molded 100% recycled natural rubber and polyurethane.
5. Advance Notification: Some advance notification of the speed-reducing devices required.
6. Spacing: Minimum spacing of 200 feet between speed cushions.

Section 503.6 shall be amended to read as follows:

503.6. Security Gates. When mechanically operated gates or barriers are provided, or required across a fire apparatus access road or street, an approved emergency vehicle traffic preemption device shall be provided that is compatible with the fire department's apparatus. The Fire Marshal shall approve the installation of security gates across a fire apparatus access road. Where security gates are installed, they shall have an approved means of emergency operation. The security gates and the emergency operation shall be maintained operational at all times. Electric gate operators, where provided, shall be listed in accordance with UL 325. Gates intended for automatic operation shall be designed, constructed and installed to comply with the requirements of ASTM F 2200. Permits are required for the installation of gates and gate control systems.

Section 503.6.1.1 and subsections shall be added to read as follows:

503.6.1.1 Distance from street, sidewalk, roadway or right-of-way. Gates shall be located on private property a minimum of 30 feet from the property line being crossed by the drive or 50 feet from the nearest edge of roadway, whichever is greater.

Provisions shall be made to allow for egress from the property and 100' for stacking of vehicles at the entry, and an area for turnaround with a clear space of thirty feet (30').

Section 503.6.1.2 Electronic operation. All access gates shall be electrically operated. A secondary/emergency power source must be available and brought online automatically upon loss of primary power to the access gates. The secondary/emergency power source shall automatically open the gates. A manual disconnect is required in the event of complete power failure. The manual disconnect shall be placed in a weather tight box, with a piano-type hinge on one side and a Knox Box PL-1 padlock and hasp on the other side.

Section 503.6.1.3 Open with key operated switch. The main gates shall open with the fire department Knox K.S. #2 key operated switch. The Knox key-operated switch shall be provided and installed by the owner. The key-operated switch shall be located 10 feet from the gate, on the left side of the approach, placed on a pedestal with the key switch facing the fire lane or road. The key switch shall be no closer than 4 feet 6 inches, or no farther than 5 feet 5 inches, from the ground. Secondary access gates do not required the KS2 Switch but do require optically controlled sensors for opening and a means of manual release in the event of system malfunction.

Section 503.6.1.4 Access codes. It shall be the owner's responsibility to program the security gate and provide the fire department with the access code and to maintain Keller Fire-Rescue's accessibility through the assigned access code.

Section 503.6.1.5 Medians. Where a security gate is installed with a median, the entry side of the gate shall have a minimum opening of 30 feet (measured back of curb to back of curb to accommodate vehicle turnaround).

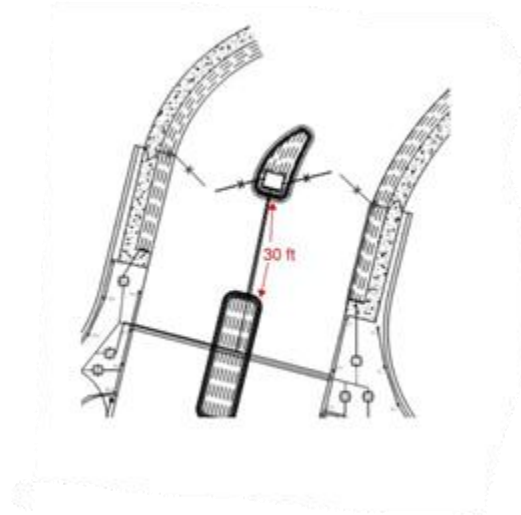

Section 503.6.1.6 Optically controlled emergency entry devices. All electronic security gates, commercial properties and residential subdivisions, shall be equipped with an optically controlled emergency override device (Opticom or equivalent) that is compatible with the optical activation device installed on fire apparatus. The devices shall be placed in both directions of travel to provide for the opening of gates as the fire apparatus approaches and exits the property. Permits for installation are required, and the Fire Marshal shall test and approve the installation upon completion, to determine compliance.

Section 505.1; change to read as follows:

Section 505.1 Address Identification. New and existing buildings shall be provided with approved address identification. The address identification shall be legible and placed in a position that is visible from the street or road fronting the property.

1. Address identification characters shall contrast with their background. Address numbers shall be Arabic numbers or alphabetical letters. Numbers shall not be spelled out. Each building number and letter shall be not less than six (6) inches high with a minimum one (1) inch stroke width. Each suite number and letter shall be not less than four (4) inches high with a minimum one-half (1/2) inch stroke width. Where required by the fire code official, address numbers shall be provided in additional approved locations to facilitate emergency response.
2. Where access is by means of a private road, buildings do not immediately front a street, and/or cannot be viewed from the public way, a monument, pole or other sign with approved 6 inch (152.4 mm) height suite/apartment numerals of a color contrasting with the background of the building or other approved means shall

be used to identify the structure. Numerals or addresses shall be posted on a minimum 20 inch (508 mm) by 30 inch (762 mm) background on border. Address shall be maintained.

Exception:

R-3 Single Family occupancies shall have approved numerals of a minimum four (4) inches high with a minimum one-half (1/2) inch stroke width and a color contrasting with the background clearly visible and legible from the street fronting the property and rear alleyway where such alleyway exists.

Section 507.4; change to read as follows:

Section 507.4 Water Supply Test Data and Information. The water supply test used for hydraulic calculation of fire protection systems shall be conducted in accordance with NFPA 291 “Recommended Practice for Fire Flow Testing and Marking of Hydrants” and within six-months of sprinkler plan submittal. Flow tests shall be scheduled through Public Works (SCADA). Water supply tests shall be conducted by the requesting party, all water valves will be operated by City of Keller water department personnel. The flow test shall be conducted in the presence of City of Keller Water Department personnel, the Flow Data Sheet shall be signed by Water Department staff member as a witness to the test. **Staff is not confirming the data acquired, only that the test was performed using City of Keller fire hydrants.** A hard copy of the Flow Data Sheet shall accompany your plan submittal. The exact location of the static/residual hydrant and the flow hydrant shall be indicated on the design drawings. The report must indicate the dominant water tank level at the time of the test and the maximum and minimum operating levels of the tank, as well, or identify applicable water supply fluctuation. The licensed contractor must then design the fire protection system based on this fluctuation information, as per the applicable referenced NFPA standard. Reference Section 903.3.5 for additional design requirements. **Test data used for plan review submittal shall not be older than six (6) months from date of submittal.**

Section 507.5 Fire hydrant systems is amended and Sections added to read as follows:

Section 507.5 Fire hydrant systems. Fire hydrant systems shall comply with Section 507.5.1 through 507.5.7.

Section 507.5.1 Where required is amended by deleting the Section 507.5.1 Where required and replacing it with Section 507.5.1 and 507.5.1.2 Where required and subsections, to read as follows:

Section 507.5.1 Where required. When a portion of the facility or building hereafter constructed or moved into, or within the jurisdiction, is more than 500 feet from a hydrant on the fire apparatus access road, as measured by an approved route around the exterior

of the facility or building, on-site fire hydrants and mains shall be provided where required by the Fire Marshal.

Exception 1 and 2 are deleted.

Section 507.5.1.2 Location. The location of fire hydrants on private property or along fire access roads shall be approved by the Fire Marshal.

Section 507.5.1.2 Fire department connections to read as follows:

Section 507.5.1.2 Fire department system connections. Fire hydrants shall be located within a 100 foot hose lay of the Fire Department Connection (FDC) along an approved route on the access road. Fire Department Connections when remotely located, shall have a 42" by 42" concrete pad below each connection.

Section 507.5.1.3 Requirements when not on public street. Fire hydrants not installed on a public street shall be looped to provide a water supply from 2 directions.

Section 507.5.4; change to read as follows:

507.5.4 Obstruction. Unobstructed access to fire hydrants shall be maintained at all times. Posts, fences, vehicles, growth, trash, storage, and other materials or objects shall not be placed or kept near hydrants, fire department inlet connections or protection systems control valves in a manner that would prevent such equipment or fire hydrants from being immediately discernable. The fire department shall not be deterred or hindered from gaining immediate access to fire protection equipment or fire hydrants.

Section 509.1.2; add new Section 509.1.2 to read as follows:

Section 509.1.2 Sign Requirements. Unless more stringent requirements apply, lettering for signs required by this section shall have a minimum height of 2 inches (50.8 mm) when located inside a building and 4 inches (101.6 mm) when located outside, or as approved by the fire code official. The letters shall be of a color that contrasts with the background.

Section 605.4 through 605.4.2.2 ; change to read as follows:

605.4 Fuel oil storage systems. Fuel oil storage systems shall be installed and maintained in accordance with this code. Tanks and fuel-oil piping systems shall be installed in accordance with Chapter 13 of the International Mechanical Code and Chapter 57.

605.4.1 Fuel oil storage in outside, aboveground tanks. In addition to the required Special Use Permit (SUP) where connected to a fuel-oil piping system, the maximum amount of fuel oil storage allowed outside above ground without additional protection shall be 660 gallons (2498 L). The storage of fuel oil above ground in quantities exceeding 660 gallons (2498 L) shall comply with NFPA 31 and Chapter 57.

605.4.1.1 Approval. Outdoor fuel oil storage tanks shall be in accordance with UL 142 or UL 2085, and also listed as double-wall/secondary containment tanks.

605.4.2 Fuel oil storage inside buildings. Fuel oil storage inside buildings shall comply with Sections 605.4.2.2 through 605.4.2.8 and Chapter 57.

605.4.2.1 Approval. Indoor fuel oil storage tanks shall be in accordance with UL 80, UL 142 or UL 2085.

605.4.2.2 Quantity limits. One or more fuel oil storage tanks containing Class II or III combustible liquid shall be permitted in a building. The aggregate capacity of all tanks shall not exceed the following:

1. 660 gallons (2498 L) in unsprinklered buildings, where stored in a tank complying with UL 80, UL 142 or UL 2085, and also listed as a double-wall/secondary containment tank for Class II liquids.
2. 1,320 gallons (4996 L) in buildings equipped with an automatic sprinkler system in accordance with Section 903.3.1.1, where stored in a tank complying with UL 142 or UL 2085. The tank shall be listed as a secondary containment tank, and the secondary containment shall be monitored visually or automatically.
3. 3,000 gallons (11 356 L) in buildings equipped with an automatic sprinkler system in accordance with Section 903.3.1.1, where stored in protected aboveground tanks complying with UL 2085 and Section 5704.2.9.7. The tank shall be listed as a secondary containment tank, as required by UL 2085, and the secondary containment shall be monitored visually or automatically.

Section 807.5.5.2 and 807.5.5.3; change to read as follows:

807.5.5.2 Artwork in Corridors. Artwork and teaching materials shall be limited on the walls of corridors to not more than 20 percent of the wall area. Such materials shall not be continuous from floor to ceiling or wall to wall. Curtains, draperies, wall hangings and other decorative material suspended from the walls or ceilings shall meet the flame propagation performance criteria of NFPA 701 in accordance with Section 807 or be noncombustible.

Exception: Corridors protected by an approved automatic sprinkler system installed in accordance with Section 903.3.1.1 shall be limited to 50 percent of the wall area.

807.5.5.3 Artwork in Classrooms. Artwork and teaching materials shall be limited on walls of classrooms to not more than 20 percent of the specific wall area to which they are attached. Curtains, draperies, wall hangings and other decorative material suspended from the walls or ceilings shall meet the flame propagation performance criteria of NFPA 701 in accordance with Section 807 or be noncombustible.

Exception: Classrooms protected by an approved automatic sprinkler system installed in accordance with Section 903.3.1.1 shall be limited to 50 percent of the wall area.

Section 901 General is amended by changing Section 901.3 and 901.5 as shown in the International Fire Code to read as follows:

Section 901.3 Permit required. Permits shall be required as set forth in Section 105.6 and 105.7 and as required by this section. A permit shall be required for the installation, reconsideration, modification, moving or alteration of any life safety system including but not limited to fire sprinkler systems, fire alarm systems, fixed extinguishing systems, access control systems and carbon dioxide sensing and monitoring systems. Work shall not begin on any system without first obtaining a permit. Any person, firm, or corporation who that violates this requirement shall be liable for a fine that is two-times the cost of the Permit or Two-Hundred Fifty Dollars (\$250.00), whichever is greater.

Exemption: Emergency repairs, due to weather may begin without a permit, providing a permit is obtained as soon as possible, but no later than the next business day.

Section 901.3.2 Permit application. The permit application shall be submitted to the office of the Fire Marshal, through the City of Keller Permitting Department and must have attached to the application detailed construction plans and a copy of the applicant's state license. The following shall be included with the plan submission: Fire department permit application, signed checklist, copy of executed contract for scope of work, state license, plan drawings, calculations, and spec sheets, in PDF format.

Section 901.3.3 Permit fee. The permit fee for the construction, repair, alteration, or relocation of a fixed system shall be in accordance with the fee schedule adopted by the City of Keller.

Section 901.5 Installation acceptance testing. Fire detection and alarm systems, emergency alarm systems, gas detection systems, fire extinguishing systems, fire hydrant systems, fire standpipe systems, fire pump systems, private fire service mains, and all other fire protection systems, and appurtenances thereto, shall be subject to acceptance tests, as contained in the installation standards and as approved by the fire code official. The fire code official shall be notified before any required acceptance testing. No system shall be approved until a complete inspection of materials and a functional test has been completed and witnessed by the Fire Marshal. The installer/technician must be present for all inspections and testing.

Section 901.6.1; add Section 901.6.1.1 to read as follows:

901.6.1.1 Standpipe Testing. Building owners/managers must maintain and test standpipe systems as per NFPA 25 requirements. The following additional requirements shall be applied to the testing that is required every 5 years:

The piping between the Fire Department Connection (FDC) and the standpipe shall be back-flushed or inspected by approved camera when foreign material is present or when caps are missing, and also hydrostatically tested for all FDC's on any type of standpipe system. Hydrostatic testing shall also be conducted in accordance with NFPA 25 requirements for the different types of standpipe systems.

For any manual (dry or wet) standpipe system not having an automatic water supply capable of flowing water through the standpipe, the tester shall connect hose from a fire hydrant or portable pumping system (as approved by the fire code official) to each FDC, and flow water through the standpipe system to the roof outlet to verify that each inlet connection functions properly. Confirm that there are no open hose valves prior to introducing water into a dry standpipe. There is no required pressure criteria at the outlet. Verify that check valves function properly and that there are no closed control valves on the system.

1. Any pressure relief, reducing, or control valves shall be tested in accordance with the requirements of NFPA 25. All hose valves shall be exercised.
2. If the FDC is not already provided with approved caps, the contractor shall install such caps for all FDC's as required by the fire code official.
3. Upon successful completion of standpipe test, place a blue tag, as required by the Texas Administrative Code, Fire Sprinkler Rules for Inspection, Test and Maintenance Service (ITM) Tag) at the bottom of each standpipe riser in the building. The tag shall be check-marked as "Fifth Year" for Type of ITM, and the note on the back of the tag shall read "5 Year Standpipe Test" at a minimum.
4. The procedures required by Texas Administrative Code Fire Sprinkler Rules with regard to Yellow Tags and Red Tags or any deficiencies noted during the testing, including the required notification of the local Authority Having Jurisdiction (fire code official) shall be followed.
5. Additionally, records of the testing shall be maintained by the owner and contractor, if applicable, as required by the State Rules mentioned above and NFPA 25.
6. Standpipe system tests where water will be flowed external to the building shall not be conducted during freezing conditions or during the day prior to expected night time freezing conditions.
7. Contact the fire code official for requests to remove existing fire hose from Class II and III standpipe systems where employees are not trained in the utilization of this firefighting equipment. All standpipe hose valves must remain in place and be

provided with an approved cap and chain when approval is given to remove hose by the fire code official.

8. Locking Knox Caps are required on all standpipe connections in publically accessible enclosed stairwells and courtyards.

Section 901.6.4; add Section 901.6.4 to read as follows:

901.6.4 False Alarms and Nuisance Alarms. False alarms and nuisance alarms shall not be given, signaled, transmitted or caused , or permitted to be given, signaled or transmitted in any manner. Fines for false and nuisance alarms are as follows:

For alarm users in non-residential and multi-family residential (four or more residential units):

- 1-3 false alarms – no false alarm fee will be charged
- 4-5 false alarms - \$50.00 for each false alarm in this range.
- 6-7 false alarms - \$75.00 for each false alarm in this range.
- 8 or more false alarms - \$100.00 for each false alarm in this range.

Section 901.7; shall be amended to read as follows:

901.7 Systems out of service. Where a required fire protection system is out of service or in the event of an excessive number of activations, the fire department and the fire code official shall be notified immediately and, where required by the fire code official, the building shall either be evacuated or an approved fire watch shall be provided for all occupants left unprotected by the shut down until the fire protection system has been returned to service. Fire Watch shall meet the requirements of 2021 IFC Section 3305.5.2 through 3305.5.4.

Add Sections 901.11 Certification, Section 901.12 Failure of system, and Section 901.13 Message alarms. To read as follows:

Section 901.11 Certification. A notarized certification indicating all work has been performed as permitted and that the work meets code requirements shall be submitted at final inspection.

Section 901.12 Failure of system. All fire alarm systems shall be designed and constructed so the failure, malfunction, or removal of any single device, or failure of the wiring to a device does not interfere with the operation of other devices in the system.

Section 901.13 Message alarms. Pre-recorded or voice message fire alarms shall not be approved unless accompanied by a fire alarm signal of audio-visual devices that meet the minimum standards of the Americans with Disabilities Act (ADA).

Section 903.1.1; change to read as follows:

903.1.1 Alternative Protection. Alternative automatic fire-extinguishing systems complying with Section 904 shall be permitted in addition to automatic sprinkler protection where recognized by the applicable standard or as approved by the fire code official.

Section 903 Automatic Sprinkler Systems is amended as follows:

903.1.3 No CPVC Piping. No fire sprinkler system shall be installed using CPVC piping.

Exception: CPVC is allowed in private residences and townhomes.

Section 903.2; add paragraph to read as follows:

Automatic Sprinklers shall not be installed in elevator machine rooms, elevator machine spaces, and elevator hoistways, other than pits where such sprinklers would not necessitate shunt trip requirements under any circumstances. Storage shall not be allowed within the elevator machine room. Signage shall be provided at the entry doors to the elevator machine room indicating "ELEVATOR MACHINERY – NO STORAGE ALLOWED."

Section 903.2; add paragraph to read as follows and delete the exception for telecommunications buildings:

Automatic Sprinklers shall not be installed in elevator machine rooms, elevator machine spaces, and elevator hoistways, other than pits where such sprinklers would not necessitate shunt trip requirements under any circumstances. Storage shall not be allowed within the elevator machine room. Signage shall be provided at the entry doors to the elevator machine room indicating "ELEVATOR MACHINERY – NO STORAGE ALLOWED."

Section 903.2.9.2 Bulk storage of tires, Section is amended by deleting that section and replacing it with a new Section 903.2.9.2, to read as follows:

Section 903.2.9.2 Bulk storage of tires. Buildings and structures where the area for the storage of tires exceeds 10,000 cubic feet shall be equipped throughout with an automatic fire sprinkler system meeting the requirements of NFPA Standard 13.

Section 903.2.9; delete exception to 903.2.9.4 and add Section 903.2.9.5 to read as follows:

903.2.9.5 Self-Service Storage Facility. An automatic sprinkler system shall be installed throughout all self-service storage facilities.

Section 903.2.11; change 903.2.11.3 and add 903.2.11.7, 903.2.11.8, and 903.2.11.9 as follows:

903.2.11.3 Buildings 35 feet or more in height. An automatic sprinkler system shall be installed throughout buildings that have one or more stories with an occupant load of 30 or more, other than penthouses in compliance with Section 1511 of the International Building Code, located 55 35 feet (16 764 10 668 mm) or more above the lowest level of fire department vehicle access, measured to the finished floor.

Delete Exception. Occupancies in Group F-2.

903.2.11.7 High-Piled Combustible Storage. For any building with a clear height exceeding 12 feet (4572 mm), see Chapter 32 to determine if those provisions apply.

903.2.11.8 Spray Booths and Rooms. New and existing spray booths and spraying rooms shall be protected by an approved automatic fire-extinguishing system.

903.2.11.9 Structures 6,000 sq. ft. or greater. An automatic sprinkler system shall be installed throughout all structures with a building area 6,000 sq. ft. or greater and in all existing buildings that are enlarged to 6,000 sq. ft. or greater. For the purpose of this provision, firewalls shall not define separate buildings.

Exception: Open parking garages in compliance with Section 406.5 of the International Building Code.

Section 903.3.1.1.1; change to read as follows:

903.3.1.1.1 Exempt Locations. When approved by the fire code official, automatic sprinklers shall not be required in the following rooms or areas where such {text unchanged}... because it is damp, of fire-resistance-rated construction or contains electrical equipment.

1. Any room where the application of water, or flame and water, constitutes a serious life or fire hazard.
2. Any room or space where sprinklers are considered undesirable because of the nature of the contents, when approved by the code official.
3. Generator and transformer rooms, under the direct control of a public utility, separated from the remainder of the building by walls and floor/ceiling or roof/ceiling assemblies having a fire-resistance rating of not less than 2 hours.
4. {Delete}
5. Elevator machine rooms, machinery spaces, and hoistways, other than pits where such sprinklers would not necessitate shunt trip requirements under any circumstances.
6. {Delete}

Section 903.3.1.2.2; change to read as follows:

903.3.1.2.2 Corridors and balconies in the means of egress. Sprinkler protection shall be provided in all corridors and for all balconies. {Delete the rest of this section.}

Section 903.3.1.2.3; delete section and replace as follows:

Section 903.3.1.2.3 Attached Garages and attics. Sprinkler protection is required in attached garages, and the following attic spaces:

1. Attics that are used, or intended for living purposes, or storage shall be protected by an automatic sprinkler system.
2. Where fuel-fired equipment is installed in an unsprinklered attic, not fewer than one quick-response intermediate temperature sprinkler shall be installed above the equipment.
3. Attic spaces of buildings that are two, or more, stories in height above grade plane, or above the lowest level of fire department vehicle access.
4. Group R-4, Condition 2 occupancy attics not required by item 1 or 3 to have sprinklers, shall comply with one of the following:
 - 4.1 Provide automatic sprinkler system protection
 - 4.2 Provide a heat detection system throughout the attic that is arranged to activate the building fire alarm system.
 - 4.3 Construct the attic using non-combustible materials.
 - 4.4 Construct the attic using fire-retardant-treated wood, complying with Section 2303.2 of the International Building Code.
 - 4.5 Fill the attic with non-combustible insulation.

Section 903.3.1.3 NFPA 13D Sprinkler Systems shall be amended to read as follows and to include the requirements of the 2003 IFC Section 903.2.10.6 for Residential Fire Sprinkler Systems in addition to the requirements of the Keller Unified Development Code;

1. Residential fire sprinklers are required for all building's 6,000 square feet or greater. For Group R-3 Occupancies the dwelling area shall only consider conditioned living space and space intended for future conditioned living space ("bonus rooms"). For the purpose of this section, area separation walls or fire barriers shall not be considered as forming separate buildings.
2. **2003 IFC Appendix D** provides regulations related to Fire Apparatus Access Roads for residential developments. According to Section D107.1, one-way access is only permissible when there are 30 or fewer lots and all dwelling units are protected by residential sprinkler systems..
3. **UDC Section 5.03. Single points of access.** Single point of access streets, including cul-de-sac streets, may exceed six hundred feet (600') in length if a residential fire sprinkler system is provided.

4. A separate tap and meter are required for residential fire sprinklers.

Add Section 903.3.1.3.1 to read as follows:

903.3.1.3.1 Residential sprinklers. Unless specifically allowed by this Code, residential sprinkler systems installed in accordance with NFPA 13D or NFPA 13R shall not be granted exemptions or reductions, commonly known as “trade-offs” permitted by other requirements of this Code. Additionally, residential sprinkler systems installed in accordance with NFPA 13R shall include attic protection. Water supply for residential fire sprinkler systems shall be provided by way of a separate tap and meter as detailed in the Keller Unified Development Code as noted below:

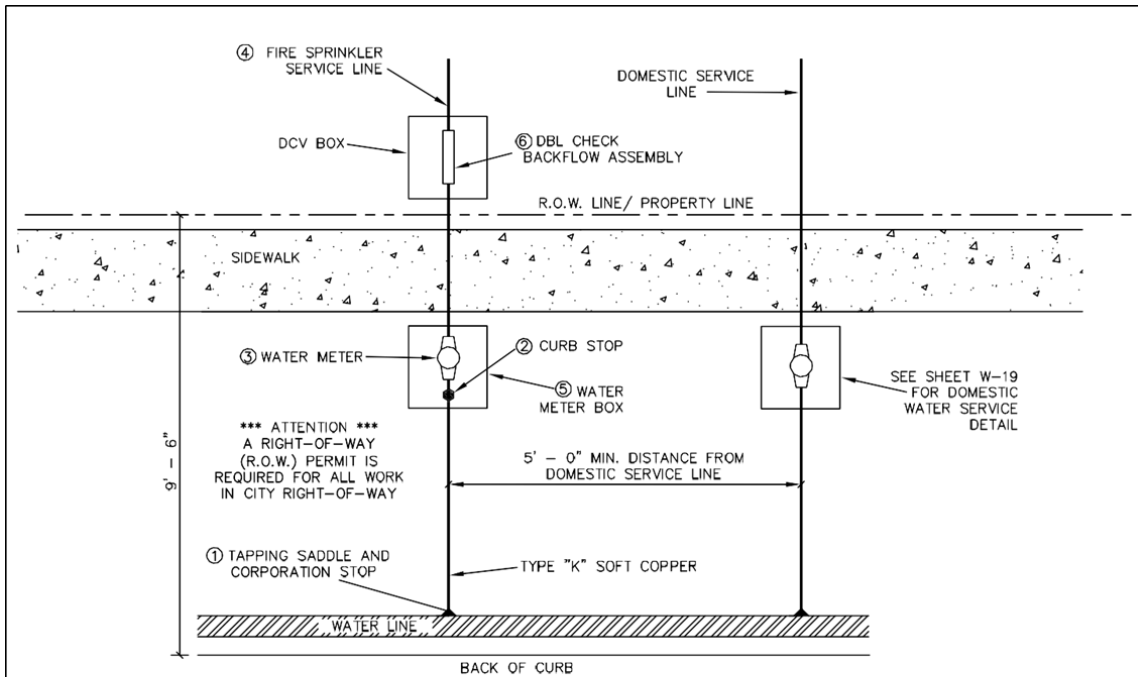

NOTES:

1. CORPORATION STOP SHALL BE CC X COMPRESSION. SEE TABLE BELOW.
2. CURB/ANGLE STOP SHALL BE COMPRESSION X MN. SEE TABLE BELOW.
3. WATER METER MUST BE SIZED PER DESIGN REQUIREMENTS BUT CAN NOT BE LESS THAN 3/4", WHICH IS INSTALLED BY THE CITY OF KELLER.
4. FIRE SPRINKLER SERVICE LINE PER FIRE SPRINKLER DESIGN SPECIFICATIONS, INSTALLED BY PLUMBER OR FIRE PROTECTION CONTRACTOR.
5. SEE TABLE BELOW.
6. DOUBLE CHECK VALVE ASSEMBLY AND BOX WILL BE INSTALLED BY PLUMBER OR FIRE PROTECTION AND INSPECTED BY CITY OF KELLER.
7. "DO NOT CLOSE VALVE" LOCKOUT TAG ATTACHED TO THE FIRE LINE METER BY CITY OF KELLER. FIRE SPRINKLER SYSTEM BACKFLOW PREVENTION DEVICES TO BE OWNED, MAINTAINED, AND TESTED BY PROPERTY OWNER.

	WATER CONSTRUCTION DETAILS RESIDENTIAL FIRE SPRINKLER SERVICE	REVISION DATE: 8/2/2012
		SHEET: W-15

Section 903.3.1.3 NFPA 13D Sprinkler Systems; add exception to read as follows:

Exception: CPVC is allowed in private, single family residences and townhomes only.

Section 903.3.1.4 shall be amended to read as follows:

903.3.1.4 Freeze protection. Freeze protection systems for automatic fire sprinkler systems shall be in accordance with the requirements of the applicable referenced NFPA standard and this section.

Section 903.3.1.4.1 Attics. Only dry-pipe, pre-action, or listed antifreeze automatic fire sprinkler systems shall be allowed to protect attic spaces.

Exception: Wet-pipe fire sprinkler systems shall be allowed to protect non-ventilated attic spaces where:

1. The attic sprinklers are supplied by a separate floor control valve assembly to allow ease of draining the attic system without impairing sprinklers throughout the rest of the building, and
2. Adequate heat shall be provided for freeze protection as per the applicable referenced NFPA standard, and
3. The attic space is a part of the building's thermal, or heat, envelope, such that insulation is provided at the roof deck, rather than at the ceiling level.

Section 903.3.1.4.2 Heat trace/insulation. Heat trace/insulation shall only be allowed where approved by the fire code official for small sections of large diameter water-filled pipe.

Section 903.3.5 Water supplies. Shall be amended as follows:

Section 903.3.5 add a second paragraph to read as follows:

Backflow devices for fire suppression systems shall include an approved double check detector backflow prevention assembly (DCDA) or approved equivalent on all fire sprinkler systems using piping material that is not approved for potable water use, and/or that does not provide for periodic flow through during each twenty-four-hour period. A reduced pressure principle detector backflow prevention assembly (RPDA) must be installed, if any solution other than the potable water can be introduced into the sprinkler system. If the inspector determines a chemical loop system can be isolated by installing an RP assembly at the point of the chemical injection, this, in conjunction with the proper installation of the DCDA in accordance with this article, will be adequate protection. All fire line assemblies shall be tested by certified testers employed by a state approved fire line contractor. Backflow testing for fire suppression systems shall comply with this section and the standards referenced in Section 903.3.1. The potable water supply shall be protected against backflow in accordance with the requirements of this section and the International Plumbing Code. In addition, the section on Acceptance Testing reads as follows: 901.5 Fire Detection and alarm systems, fire-extinguishing systems, fire hydrant systems, fire standpipe systems, fire pump systems, private fire service mains and all

other fire protection systems and appurtenances thereto shall be subject to acceptance tests as contained in the installation standards and as approved by the fire code official. The backflow device is an appurtenance and as such, Fire Prevention will not schedule a Hydro/Visual test until there is documentation of a “passing” backflow test.

Section 903.3.5; add a third paragraph to read as follows:

Water supply as required for such systems shall be provided in conformance with the supply requirements of the respective standards; however, every water-based fire protection system shall be designed with a 10 psi safety factor. Reference Section 507.4 for additional design requirements.

Section 903.3.7 Fire Department Connections. Is amended by deleting that section and adding the following section, to read as follows:

Section 903.3.7 Fire Department Connections. The location of Fire Department Connections shall be approved by the fire code official. Locking caps, of an approved style or vendor may be required by the fire code official. Locking caps shall be installed as replacements for lost or damaged caps when deemed necessary by the fire code official to address tampering problems at existing facilities.

Section 903.4; Amend Section 903.4 and add a second paragraph after the exceptions to read as follows:

Section 903.4 Sprinkler system supervision and alarms. Valves controlling the water supply for automatic sprinkler systems, pumps, tanks, water levels and temperatures, critical air pressures and waterflow switches on all sprinkler systems, new and existing, shall be electrically supervised by a listed fire alarm control unit.

Add second paragraph after the exceptions to read as follows: Sprinkler and standpipe system water-flow detectors shall be provided for each floor tap to the sprinkler system and shall cause an alarm upon detection of water flow for more than 45 seconds. All control valves in the sprinkler and standpipe systems except for fire department hose connection valves shall be electrically supervised to initiate a supervisory signal at the central station upon tampering.

Section 903.4.2; add second paragraph to read as follows:

The alarm device required on the exterior of the building shall be a weatherproof horn/strobe notification appliance with a minimum 75 candela strobe rating, installed as close as practicable to the fire department connection.

Section 903.4; add a second paragraph after the exceptions to read as follows:

Sprinkler and standpipe system water-flow detectors shall be provided for each floor tap to the sprinkler system and shall cause an alarm upon detection of water flow for more than 45 seconds. All control valves in the sprinkler and standpipe systems except for fire department hose connection valves shall be electrically supervised to initiate a supervisory signal at the central station upon tampering.

Section 903.4.2; add second paragraph to read as follows:

The alarm device required on the exterior of the building shall be a weatherproof horn/strobe notification appliance with a minimum 75 candela strobe rating, installed as close as practicable to the fire department connection. Also required is a water-motor activated gong.

Section 903.7 shall be added to read as follows:

Section 903.7 Automatic Sprinkler System Room Access. Sprinkler system risers providing protection for multi-family and commercial buildings must be located in a ground floor room directly accessible from the exterior of the building. The door shall be labeled as "SPRINKLER RISER ROOM" or FACP/SPRINKLER RISER ROOM". The minimum size of the room shall be 36 sq. ft., with the minimum dimension being 6 ft. and once stacked shall be a minimum of eighteen inches (18") from the outside edge of the flange to the inside edge of the finished wall.

Section 903.8 Installation schedule is amended by adding 903.8 Installation schedule, to read as follows:

Section 903.8 Installation schedule. Approved fire sprinkler systems shall be operational in a building under construction when:

1. The building is sufficiently constructed to the point that the exterior sheathing and roof have been installed; or
2. At the start of combustible interior construction; or
3. When there is an accumulation of combustible material within the building including, but not limited to, building supplies, rubbish, and furniture, or
4. When the building goes under conditioned atmosphere.

Section 905.2; change to read as follows:

905.2 Installation Standard. Standpipe systems shall be installed in accordance with this Section, Section 912 and NFPA 14. Manual dry standpipe systems shall be supervised with a minimum of 10 psig and a maximum of 40 psig air pressure with a high/low alarm.

Section 905.3; add Section 905.3.9 and exception to read as follows:

905.3.9 Buildings. In buildings exceeding 10,000 square feet in area per story or where any portion of the building's interior area is more than 200 feet (60960 mm) of travel, vertically and horizontally, from the nearest point of fire department vehicle access, Class I automatic wet or manual wet standpipes shall be provided.

Exceptions:

1. Automatic dry, semi-automatic dry, and manual dry standpipes are allowed as provided for in NFPA 14, where approved by the fire code official.
2. R-2 occupancies of four stories or less in height having no interior corridors.

Section 905.4, change Item 1, 3, and 5, and add Item 7 to read as follows:

1. In every required exit stairway, a hose connection shall be provided for each story above and below grade plane. Hose connections shall be located at every landing, on each story, unless otherwise approved by the fire code official.
2. {No change.}
3. In every exit passageway, at the entrance from the exit passageway to other areas of a building.
Exception: Where floor areas adjacent to an exit passageway are reachable from an exit stairway hose connection by a {remainder of text unchanged.}
4. {No change.}
5. Where the roof has a slope less than four units vertical in 12 units horizontal (33.3-percent slope), each standpipe shall be provided with a two-way hose connection located to serve the roof or at the highest landing of an exit stairway with stair access to the roof provided in accordance with Section 1011.12.
6. {No change.}
7. When required by this Chapter, standpipe connections shall be placed adjacent to all required exits to the structure and at two hundred feet (200') intervals along corridors thereafter, or as otherwise approved by the fire code official.
8. Locking standpipe caps are required for all standpipe connections.

Section 905.9; add a second paragraph after the exceptions to read as follows:

Sprinkler and standpipe system water-flow detectors shall be provided for each floor tap to the sprinkler system and shall cause an alarm upon detection of water flow for more than 45 seconds. All control valves in the sprinkler and standpipe systems except for fire department hose connection valves shall be electrically supervised to initiate a supervisory signal at the central station upon tampering.

Section 906.1(1); delete Exception 3 in its entirety.

Section 907.1; add Section 907.1.4 and 907.1.4.1 to read as follows:

907.1.4 Design Standards. All alarm systems new or replacement shall be addressable. Alarm systems serving more than 20 smoke detectors shall be analog addressable. A system employing a DACT shall employ one telephone landline as the primary communicator with a separate cellular dialer as the back-up. Where 100% copper phone lines are not available, cellular dialers may be employed as both the primary and secondary communicators when there are two separate providers. **Sole path communication is prohibited in the City of Keller.**

Section 907.2; change, delete the second paragraph and replace with a paragraph to read as follows:

907.2 Where required in buildings and structures. An approved fire alarm system installed in accordance with the provisions of this code and NFPA 72 shall be provided in new buildings in accordance with Sections 907.2.1 through 907.2.23 and provide

occupant notification in accordance with Section 907.5, unless other requirements are provided by another section of this code.

An approved fire alarm system shall be installed in existing buildings that are protected by a previously installed automatic sprinkler system in accordance with the currently published Edition of NFPA 72..

Section 907.2.1; change to read as follows delete exception:

907.2.1 Group A. A manual fire alarm system that activates the occupant notification system in accordance with Section 907.5 shall be installed in Group A occupancies having an occupant load 100 or more persons, or where the occupant load is more than 100 persons above or below the lowest level of exit discharge. Group A occupancies not separated from one another in accordance with Section 707.3.10 of the International Building Code shall be considered as a single occupancy for the purposes of applying this section. Portions of Group E occupancies occupied for assembly purposes shall be provided with a fire alarm system as required for the Group E occupancy.

Delete Exception in its entirety.

Activation of fire alarm notification appliances shall:

1. Cause illumination of the means of egress with light of not less than 1 foot-candle (11 lux) at the walking surface level, and
2. Stop any conflicting or confusing sounds and visual distractions.

Section 907.2.3; change to read as follows:

Section 907.2.3; change to read as follows:

907.2.3 Group E. A manual fire alarm system that initiates the occupant notification signal utilizing an emergency voice/alarm communication system meeting the requirements of Section 907.5.2.2 and installed in accordance with Section 907.6 shall be installed in Group E educational occupancies. When automatic sprinkler systems or smoke detectors are installed, such systems or detectors shall be connected to the building fire alarm system. An approved smoke detection system shall be installed in Group E day care occupancies. Unless separated by a minimum of 100' open space, all buildings, whether portable buildings or the main building, will be considered one building for alarm occupant load consideration and interconnection of alarm systems.

Exceptions:

1. {No change.}
- 1.1 Residential In-Home day care with not more than 12 children may use interconnected single station detectors in all habitable rooms. (For care of more than five children 2 1/2 or less years of age, see Section 907.2.6.) {No change to remainder of exceptions.}

Section 907.2.10; change to read as follows:

907.2.10 Group S. A manual fire alarm system that activates the occupant notification system in accordance with Section 907.5 shall be installed in Group S public- and self-storage occupancies for interior corridors and interior common areas. Visible notification appliances are not required within storage units.

Exception: {No change.}

Section 907.2.12, Exception 3; change to read as follows:

3. Open air portions of buildings with an occupancy in Group A-5 in accordance with Section 303.1 of the International Building Code; however, this exception does not apply to accessory uses including but not limited to sky boxes, restaurants, and similarly enclosed areas.

Section 907.4.2; add Section 907.4.2.7 to read as follows:

907.4.2.7 Type. Manual alarm initiating devices shall be an approved double action type.

Section 907.6.1; add Section 907.6.1.1 to read as follows:

907.6.1.1 Wiring Installation. All fire alarm systems shall be installed in such a manner that a failure of any single initiating device or single open in an initiating circuit conductor will not interfere with the normal operation of other such devices. All signaling line circuits (SLC) shall be installed in such a way that a single open will not interfere with the operation of any addressable devices (Class A). Outgoing and return SLC conductors shall be installed in accordance with NFPA 72 requirements for Class A circuits and shall have a minimum of four (4) feet separation horizontal and one (1) foot vertical between supply and return circuit conductors. The initiating device circuit (IDC) from a signaling line circuit interface device shall be wired Class A, provided the distance from the interface device to the initiating device is ten feet or less. All wiring, SLC, IDC, NAC shall be wired Class A. Minimum fire alarm design shall include a manual pull station at each exit and notification devices throughout.

Section 907.6.3; delete all four Exceptions.

Section 907.6.6; – add sentence at end of paragraph to read as follows:

See 907.6.3 for the required information transmitted to the supervising station.

Section 910.2; change Exception 2. and 3. to read as follows:

2. Only manual smoke and heat removal shall be required in areas of buildings equipped with early suppression fast-response (ESFR) sprinklers. Automatic smoke and heat removal is prohibited.

3. Only manual smoke and heat removal shall be required in areas of buildings equipped with control mode special application sprinklers with a response time index of $50(m^*S)^{1/2}$ or less that are listed to control a fire in stored commodities with 12 or fewer sprinklers. Automatic smoke and heat removal is prohibited.

Section 910.2; add subsections 910.2.3 with exceptions to read as follows:

910.2.3 Group H. Buildings and portions thereof used as a Group H occupancy as follows:

1. In occupancies classified as Group H-2 or H-3, any of which are more than 6,000 square feet (1394 m^2) in single floor area.

Exception: Buildings of noncombustible construction containing only noncombustible materials.

2. In areas of buildings in Group H used for storing Class 2, 3, and 4 liquid and solid oxidizers, Class 1 and unclassified detonable organic peroxides, Class 3 and 4 unstable (reactive) materials, or Class 2 or 3 water-reactive materials as required for a high-hazard commodity classification.

Exception: Buildings of noncombustible construction containing only noncombustible materials.

Section 910.4.3.1; change to read as follows:

910.4.3.1 Makeup air. Makeup air openings shall be provided within 6 feet (1829 mm) of the floor level. Operation of makeup air openings shall be automatic. The minimum gross area of makeup air inlets shall be 8 square feet per 1,000 cubic feet per minute (0.74 m² per 0.4719 m³/s) of smoke exhaust.

Section 912.2; add Section 912.2.3 to read as follows:

912.2.3 Hydrant Distance. An approved fire hydrant shall be located within 100 feet of the fire department connection as the fire hose lays along an unobstructed path as approved by the AHJ.

Section 913.2.1; add second paragraph and exception to read as follows:

When located on the ground level at an exterior wall, the fire pump room shall be provided with an exterior fire department access door that is not less than 3 ft. in width and 6 ft. 8 in. in height, regardless of any interior doors that are provided. A key box of an approved type or vendor shall be provided at this door, as required by Section 506.1.

Exception: When it is necessary to locate the fire pump room on other levels or not at an exterior wall, the corridor leading to the fire pump room access from the exterior of the building shall be provided with equivalent fire resistance as that required for the pump room, or as approved by the fire code official. Access keys shall be provided in the key box as required by Section 506.1.

Section 914.3.1.2; change to read as follows:

914.3.1.2 Water Supply to required Fire Pumps. In buildings that are more than 120 feet (128 m) in building height, required fire pumps shall be supplied by connections to no fewer than two water mains located on different streets. Separate supply piping shall be provided between each connection to the water main and the pumps. Each connection and the supply piping between the connection and the pumps shall be sized to supply the flow and pressure required for the pumps to operate.

Exception: {No change to exception}

Section 1003.6 Means of egress continuity is amended by adding Section 1003.6.1 vehicle parking, to read as follows:

Section 1003.6.1 Vehicle parking. No motor vehicle shall be parked within 10 feet of any patio, stairs, or egress path at any apartment, multi-family building, hotel, motel, educational occupancy or commercial structure, unless in an approved parking space.

Section 1006.2.2.7; add a new Section 1006.2.2.7 as follows:

1006.2.2.7 Electrical Rooms. For electrical rooms, special exiting requirements may apply. Reference the Electrical Code as adopted.

Section 1009.8; add the following Exception 7:

Exception:

{previous exceptions unchanged}

7. Buildings regulated under State Law and built in accordance with State registered plans, including any variances or waivers granted by the State, shall be deemed to be in compliance with the requirements of Section 1009 and Chapter 11.

Section 1010.1.9.5 Bolt Locks; amend Exceptions 3 and 4 to read as follows:

Exceptions:

3. Where a pair of doors serves an occupant load of less than 50 persons in a Group B, F, M or S occupancy. {Remainder unchanged}

4. Where a pair of doors serves a Group A, B, F, M or S occupancy {Remainder unchanged}

Section 1020.1 Construction; add Exception 6 to read as follows:

6. In group B occupancies, corridor walls and ceilings need not be of fire-resistive construction within a single tenant space when the space is equipped with approved automatic smoke-detection within the corridor. The actuation of any detector shall activate self-annunciating alarms audible in all areas within the corridor. Smoke detectors shall be connected to an approved automatic fire alarm system where such system is provided.

Section 1032.2; change to read as follows:

1031.2 Reliability. Required exit accesses, exits and exit discharges shall be continuously maintained free from obstructions or impediments to full instant use in the case of fire or other emergency. An exit or exit passageway shall not be used for any purpose that interferes with a means of egress.

Section 1103.3; add sentence to end of paragraph as follows:

Provide emergency signage as required by Section 604.4.

1103.5 Sprinkler Systems change to read as follows:

An automatic sprinkler system shall be provided in all existing buildings 6,000 square feet or larger in accordance with this section, when there is a change of owner, use or occupant. The fire sprinkler system installation shall be completed prior to occupancy by the owner/tenant. The fire code official is authorized to decrease the installation timeframe based on the occupant and/or use of the building to ensure life safety.

Section 1103.5; add Section 1103.5.5 to read as follows:

1103.5.6 Spray Booths and Rooms. Existing spray booths and spray rooms shall be protected by an approved automatic fire-extinguishing system in accordance with Section 2404.

Section 1103.7; add Section 1103.7.7 and 1103.7.7.1 to read as follows:

1103.7.7 Fire Alarm System Design Standards. Where an existing fire alarm system is upgraded or replaced, all devices shall be addressable.

Delete Exception in it's entirety.

Section 1103.7.7.1 Communication requirements. Refer to Section 907.6.6 for applicable requirements

Section 1203; change and add to read as follows:

1203.1.1 {No change}

1203.1.2 {No change}

1203.1.3 Installation. Emergency power systems and standby power systems shall be installed in accordance with the International Building Code, NFPA 70, NFPA 110, and NFPA 111. Existing installations shall be maintained in accordance with the original approval, except as specified in Chapter 11.

1203.1.4 through 1203.1.9 {No changes to these sections}

1203.1.10 Critical Operations Power Systems (COPS). For Critical Operations Power Systems necessary to maintain continuous power supply to facilities or parts of facilities that require continuous operation for the reasons of public safety, emergency management, national security, or business continuity, see NFPA 70.

1203.2 Where required. Emergency and standby power systems shall be provided where required by Sections 1203.2.1 through 1203.2.26, or elsewhere identified in this code, or any other referenced code.

1203.2.1 through 1203.2.3 {No change}

1203.2.4 Emergency Voice/alarm communications systems. Emergency power shall be provided for emergency voice/alarm communications systems in the following occupancies, or as specified elsewhere in this code, as required in Section 907.5.2.2.5. The system shall be capable of powering the required load for a duration of not less than 24 hours, as required in NFPA 72.

- Covered and Open Malls, Section 907.2.19 and 914.2.3
- Group A Occupancies, Sections 907.2.1 and 907.5.2.2.4.
- Special Amusement Buildings, Section 907.2.11
- High-rise Buildings, Section 907.2.12
- Atriums, Section 907.2.13
- Deep Underground Buildings, Section 907.2.18

1203.2.5 through 1203.2.13 {No change}

1203.2.14 Means of egress illumination. Emergency power shall be provided for means of egress illumination in accordance with Sections 1008.3 and 1104.5.1. minimum of ninety (90)minutes.

1203.2.15 Membrane Structures.

Emergency power shall be provided for exit signs in temporary tents and membrane structures in accordance with Section 3103.12.6. (90 minutes) Standby power shall be provided for auxiliary inflation systems in permanent membrane structures in accordance with Section 2702 of the International Building Code. (4 hours) Auxiliary inflation systems shall be provided in temporary air-supported and air-inflated membrane structures in accordance with section 3103.10.4.

1203.2.16 {No change}

1203.2.17 Smoke Control Systems.

Standby power shall be provided for smoke control systems in the following occupancies, or as specified elsewhere in this code, as required in Section 909.11:

- Covered Mall Building, International Building Code, Section 402.7
- Atriums, International Building Code, Section 404.7
- Underground Buildings, International Building Code, Section 405.8

- Group I-3, International Building Code, Section 408.4.2
- Stages, International Building Code, Section 410.2.5
- Special Amusement Buildings (as applicable to Group A's), International Building Code, Section 411.1
- Smoke Protected Seating, Section 1029.6.2.

1203.2.18 {No change}

1203.2.19 Covered and Open Mall Buildings.

Emergency power shall be provided in accordance with Section 907.2.19 and 914.2.3.

1203.2.20 Airport Traffic Control Towers.

A standby power system shall be provided in airport traffic control towers more than 65 ft. in height. Power shall be provided to the following equipment:

1. Pressurization equipment, mechanical equipment and lighting.
2. Elevator operating equipment.
3. Fire alarm and smoke detection systems.

1203.2.21 Smokeproof Enclosures and Stair Pressurization Alternative.

Standby power shall be provided for smokeproof enclosures, stair pressurization alternative and associated automatic fire detection systems as required by the International Building Code, Section 909.20.6.2.

1203.2.22 Elevator Pressurization. Standby power shall be provided for elevator pressurization system as required by the International Building Code, Section 909.21.5.

1203.2.23 Elimination of Smoke Dampers in Shaft Penetrations. Standby power shall be provided when eliminating the smoke dampers in ducts penetrating shafts in accordance with the International Building Code, Section 717.5.3, exception 2.3.

1203.2.24 Common Exhaust Systems for Clothes Dryers. Standby power shall be provided for common exhaust systems for clothes dryers located in multistory structures in accordance with the International Mechanical Code, Section 504.10, Item 7.

1203.2.25 Hydrogen Cutoff Rooms. Standby power shall be provided for mechanical ventilation and gas detection systems of Hydrogen Cutoff Rooms in accordance with the International Building Code, Section 421.

1203.2.26 Means of Egress Illumination in Existing Buildings. Emergency power shall be provided for means of egress illumination in accordance with Section 1104.5 when required by the fire code official. (90 minutes in I-2, 60 minutes elsewhere.)

1203.3 through 1203.6 {No change}

1203.7 Energy Time Duration. Unless a time limit is specified by the fire code official, in this chapter or elsewhere in this code, or in any other referenced code or standard, the

emergency and standby power system shall be supplied with enough fuel or energy storage capacity for not less than 2-hour full-demand operation of the system.

Exception: Where the system is supplied with natural gas from a utility provider and is approved.

Section 2304.1; change to read as follows:

2304.1 Supervision of Dispensing. The dispensing of fuel at motor fuel-dispensing facilities shall be in accordance with the following:

1. Conducted by a qualified attendant; and/or, 2. Shall be under the supervision of a qualified attendant; and/or
3. Shall be an unattended self-service facility in accordance with Section 2304.3.

At any time the qualified attendant of item Number 1 or 2 above is not present, such operations shall be considered as an unattended self-service facility and shall also comply with Section 2304.3.

Section 2401.2; delete this section.

Section 3103.3.1; delete this section.

Table 3206.2, footnote h; change text to read as follows:

h. Where storage areas are protected by either early suppression fast response (ESFR) sprinkler systems or control mode special application sprinklers with a response time index of $50 (m \cdot s)^{1/2}$ or less that are listed to control a fire in the stored commodities with 12 or fewer sprinklers, installed in accordance with NFPA 13, manual smoke and heat vents or manually activated engineered mechanical smoke exhaust systems shall be required within these areas.

Table 3206.2, footnote j; add footnote j to row titled "High Hazard" and Greater than 300,000 sf² to read as follows:

j. High hazard high-piled storage areas shall not exceed 500,000 sf². A 2-hour fire wall, constructed in accordance with Section 706 of the International Building Code, shall be used to divide high-piled storage exceeding 500,000 square feet in area.

Section 3310.1; add sentence to end of paragraph to read as follows:

When fire apparatus access roads are required to be installed for any structure or development, they shall be approved prior to the time at which construction has progressed beyond completion of the foundation of any structure. Completion of the access road includes striping.

Section 5601.1.3; change to read as follows:

5601.1.3 Fireworks. The possession, manufacture, storage, sale, handling, and use of fireworks are prohibited.

Exceptions:

1. Only when approved for fireworks displays, storage, and handling of fireworks as allowed in Section 5604 and 5608.
2. The use of fireworks for approved fireworks displays as allowed in Section 5608.
3. {Delete remainder of text.}

Section 5703.6; add a sentence at the end to read as follows:

An approved method of secondary containment shall be provided for underground tank and piping systems.

Section 5704.2.9.6.1 amend to read as follows:

5704.2.9.6.1 Locations where above ground tanks are prohibited. The storage of Class I and Class II liquids in permanent above ground tanks outside of buildings is prohibited within the Keller City Limits unless approved by Specific Use Permit and with approval of the Fire Marshal.

Section 5704.2.11.4; add a sentence to read as follows:

5704.2.11.4 Leak Prevention. Leak prevention for underground tanks shall comply with Sections 5704.2.11.4.1 through 5704.2.11.4.3. An approved method of secondary containment shall be provided for underground tank and piping systems.

Section 5704.2.11.4.2; change to read as follows:

5704.2.11.4.2 Leak Detection. Underground storage tank systems shall be provided with an approved method of leak detection from any component of the system that is designed and installed in accordance with NFPA 30 and as specified in Section 5704.2.11.4.3.

Section 5704.2.11.4.3; add Section 5704.2.11.4.3 to read as follows:

5704.2.11.4.3 Observation Wells. Approved sampling tubes of a minimum 4 inches in diameter shall be installed in the backfill material of each underground flammable or combustible liquid storage tank. The tubes shall extend from a point 12 inches below the average grade of the excavation to ground level and shall be provided with suitable surface access caps. Each tank site shall provide a sampling tube at the corners of the excavation with a minimum of 4 tubes. Sampling tubes shall be placed in the product line excavation within 10 feet of the tank excavation and one every 50 feet routed along product lines towards the dispensers, a minimum of two are required.

Delete Section 5707 On-Demand Mobile Fueling Operations in its entirety.

Section 6103.2.1; add Section 6103.2.1.8 to read as follows:

6103.2.1.8 Jewelry Repair, Dental Labs and Similar Occupancies. Where natural gas service is not available, portable LP-Gas containers are allowed to be used to supply approved torch assemblies or similar appliances. Such containers shall not exceed 20-pound (9.0 kg) water capacity. Aggregate capacity shall not exceed 60-pound (27.2 kg) water capacity. Each device shall be separated from other containers by a distance of not less than 20 feet.

Section 6104.2, Exception; add an exception 2 to read as follows:

Exceptions:

1. {existing text unchanged}
2. Except as permitted in Sections 308 and 6104.3.2, LP-gas containers are not permitted in residential areas.

Section 6104.3; add Section 6104.3.3 to read as follows:

6104.3.3 Spas, Pool Heaters, and Other Listed Devices. LP-gas containers are allowed to be used to supply spa and pool heaters or other listed devices. Such container shall not exceed 250-gallon water capacity per lot. See Table 6104.3 for location of containers. Installation shall be in accordance with the Texas Administrative Code Title 16, Part 1, Chapter 9, Subchapter B.

Exception: Lots where LP-gas can be off-loaded wholly on the property where the tank is located may install up to 500 gallon above ground or 1,000 gallon underground approved containers.

Section 6107.4 and 6109.13; change to read as follows:

6107.4 Protecting Containers from Vehicles. Where exposed to vehicular damage due to proximity to alleys, driveways or parking areas, LP-gas containers, regulators and piping shall be protected in accordance with NFPA 58 and Section 312.

6109.13 Protection of Containers. LP-gas containers shall be stored within a suitable enclosure or otherwise protected against tampering. Vehicle impact protection shall be provided as required by Section 6107.4.

Exception: {Deleted}

Table B105.2; change footnote a. to read as follows:

The reduced fire-flow shall be not less than 1,500 gallons per minute.

Appendix C103.1 Hydrant Spacing; shall be amended to read as follows and C103.2 and C103.3 shall be deleted:

C103 Fire Hydrant Spacing.

1. **Commercial and Industrial Areas**

- a. Fire hydrants shall be located no more than a five hundred foot (500') truck hose lay distance to all points of any structure or combustible storage area on the lot.
- b. Fire hydrants located on the opposite side of a street, designated as four lanes or larger on the current City Thoroughfare Plan, shall not be considered acceptable for meeting hydrant coverage requirements.
- c. Fire hydrants shall be positioned to allow truck hose lays to follow normal traffic access to the site.
- d. Fire hydrants shall be spaced at no more than three hundred foot (300') intervals.

2. Residential Areas

- a. Fire hydrants shall be placed on block corners or near the center of the block to place every structure within a five hundred foot (500') truck hose lay distance from fire hydrant coverage.
- b. Fire hydrants located on the opposite side of a street, designated as four lanes or larger on the current City Thoroughfare Plan, shall not be considered acceptable for meeting hydrant coverage requirements.
- c. Fire hydrants shall be positioned to allow truck hose lays to follow normal traffic access to the site.
- d. Fire hydrants shall be spaced at no more than five hundred foot (500') intervals.
- e. Hydrants shall be positioned on the same side of the access road as the Fire Department Connection.

Appendix C 104 Hydrant Spacing, shall be deleted entirely.

Appendix D; Change Appendix D102.1 to read as follows:

D102.1 Access and Loading. Facilities, buildings, or portions of buildings, hereafter, constructed shall be accessible to fire department apparatus by way of an approved fire apparatus access road with an asphalt, concrete, or other approved driving surface capable of supporting the imposed load of apparatus weighing up to 85,000 pounds. Buildings 6,000 square feet or larger shall have fire apparatus roads on all four sides of the building to allow for adequate firefighting capabilities.

Appendix D Section 103 Minimum Specifications. Change D103.2 to read as follows:

D103.2 Grade. Fire apparatus access roads shall not exceed 5 percent in grade.

Appendix D103.5 Fire apparatus access road gates shall be amended to read as follows:

1. Where a single gate is provided, the gate width shall be not less than 24 feet. Where a fire apparatus access road consists of a divided roadway, the gate width shall be not less than 16 feet.

Appendix L Requirements for Fire Fighter Air Replenishment Systems is amended as follows:

Section L101.2 is hereby added to read as follows:

L101.2 Required locations. A FARS shall be provided in all new construction when any one of the following conditions occur:

1. Any new building 5 or more stories in height from the lowest level of fire department access.
2. Any building determined to be a high-rise.
3. Any new building with 2 or more stories below grade.
4. Any new building with a total area of 500,000 square feet or more in size.
5. Any new R-2 occupancy, or mixed-use occupancy, in which the total fire area exceeds 400,000 square feet and is 4 stories or more from the lowest level of fire department access.

Section L101.3.1 is hereby added to read as follows:

L101.3.1 Location. Each stairwell shall have a supply riser. Fill stations for refilling breathing air cylinders shall be located as follows or otherwise as required by the fire code official:

1. Multi-level Buildings.
 - a. Single stairwell, on all even floor levels.
 - b. Two stairwells, on alternated floors between the stairwells
 - c. Three or more stairwells
 - i. Central stairwell on all floors.
 - ii. Alternating floors in other stairwells as determined by the fire code official.
2. Large-area buildings.

- a. At interior structural support columns, adjacent to interior fire department hose valves.

Section L101.4 is hereby added to read as follows:

L101.4 Identification. In large area buildings the supporting column where the fill stations are located shall be identified with a White 4-inch 3M Diamond Grade reflective striping at the ceiling and floor levels.

Section L103.1.1 is added to read as follows:

L103.1.1 Submittals. Plans and specifications shall be from a Firefighter Air Replenishment company and sealed by a Texas licensed PE.

Section L104.15 is hereby amended by adding a sentence to read as follows:

Air monitoring shall be required at a location approved by the fire code official.

Section L104.5 is amended to read as follows:

L104.5 Breathing air supply. The FARS shall be supplied by a minimum of one external mobile air connection in accordance with Section L104.14. Additional external mobile air connection may be required depending on the size of the facility and complexity. A stored pressure air supply shall be supplied by an external mobile air connection providing a means to bypass the stored pressure air supply located at the external mobile air connection.

Section L104.5.1 is amended to read as follows:

L104.5.1. Stored pressure air supply. A stored pressure air supply shall be required and designed based on Chapter 24 of NFPA 1901 except that provisions applicable only to mobile apparatus or not applicable to system design shall not apply. A stored pressure air supply shall be capable of refilling not less than 50 empty breathing air cylinders.

Section L104.5.1.2 is hereby added to read as follows:

L104.5.1.2 Location. Stored pressure air supply shall be located in the fire command room or fire protection equipment room as determined by the fire code official.

Section L104.13.1 to read as follows:

Section L104.13.1 Required Location. In new buildings, FARS shall be required when any of the following conditions occur:

1. Any new building 5 or more stories in height.
2. Any new building with 2 or more floors below grade.
3. Any new building 500,000 square feet or more in size.

Each stairwell shall have a supply riser. SCBA fill panels shall be located on odd numbered floors commencing at the first level in the primary stairwell and on even numbered floors commencing at level 2 in the remaining stairwells.

Fill panels in buildings over 500,000 square feet shall be located adjacent to each standpipe connection.

APPENDIX P PERMIT FEES

Section P105 General.

P101.1 The City of Keller shall collect the approved fees for inspections, annual permits, and other related permits as required by this Ordinance. Fees are adopted by the City Council annually when the City Council adopts the City budget.

P101.2 Fire code construction permit fees shall be based on the contracted value of the work being permitted. Fees are as stated in the approved fee schedule as noted in **P102.17** and adopted by the City of Keller. When a permit is required, the permit fee shall be doubled when work or construction has occurred without obtaining the appropriate permits or \$250.00, whichever is greater

P101.3 Fire Code operational permit fees shall be annual and due on the anniversary date of the permit issue, unless otherwise indicated on the permit. Operational permit fees shall be Fifty Dollars (\$50.00) per permit per year.

P101.4 Payment of annual permit fees shall be the responsibility of the property owner, business owner/manager, contractor, or other responsible individual as applicable.

P101.5 The Fire Marshal may request copies of bid documents or other items to verify the estimated cost of construction when calculating permit fees.

P101.6 A permit application shall be submitted through the City of Keller eTrackIT system.

P101.7 Contractor documentation. Any organization desiring to perform work for which a permit is required, shall provide documentation to the Development Services Permit Desk. Such documentation shall include, but not be limited to, a copy of all applicable State licenses, driver's license, current proof of Financial Responsibility and contact information and shall be submitted by the licensed contractor.

P101.8 Work shall not begin on any construction requiring a fire code permit before the permit is obtained unless approved by the Fire Marshal.

P101.9 Inspection requests. It shall be the duty of the permit holder or their duly authorized agent to notify the fire code official when work is ready for inspection. It shall be the duty of the permit holder to provide access to and means for inspections of such work that are required by this Code.

P101.10 Approval required. Work shall not be done beyond the point indicated in each successive inspection without first obtaining the approval of the fire code official. The fire code official, upon notification, shall make the requested inspections and shall either

indicate the portion of the construction that is satisfactory as completed, or notify the permit holder or his or her agent wherein the same fails to comply with this Code. Any portions that do not comply shall be corrected and such portion shall not be covered or concealed until authorized by the fire code official.

P102 Required construction permits. For any and all new installations, and modifications to existing fire and life safety systems, including but not limited to **Sections P102.1 through P102.16** of this document and, **Section 105 Permits, of the 2021 Edition of the International Fire Code.** A construction permit issued by the Fire Marshal shall be required for work as set forth in the above referenced Sections.

P102.1 Automatic fire-extinguishing systems. The permit fee for the installation of or modification to any residential or commercial automatic fire-extinguishing system required by Section 105.7.1 and Section 903 as amended and adopted, shall be determined by the cost of construction and the fee shall be calculated based on the fee schedule as required by the most recent ordinances of the City of Keller. A plan review fee equal to sixty-five percent (65%) of the construction permit fee will also apply.

P102.2 Battery Systems. The permit fee for the installation of stationary battery systems required by Section 105.7.2 shall be determined by the cost of construction and the fee shall be calculated based on the fee schedule as required by the most recent ordinances of the City of Keller. A plan review fee equal to sixty-five percent (65%) of the construction permit fee will also apply.

P102.3 Compressed gases. The permit fee to install, repair damage to, abandon, remove, place temporarily out of service, or close or substantially modify a compressed gas system required by Section 105.7.4 shall be determined by the cost of construction and the fee shall be calculated based on the fee schedule as required by the most recent ordinances of the City of Keller. A plan review fee equal to sixty-five percent (65%) of the construction permit fee will also apply.

P102.4 Cryogenic fluids. The permit fee for the installation of or alteration to cryogenic fluid storage systems required by Chapter 55 and Section 105.7.5 shall be determined by the cost of construction and the fee shall be calculated based on the fee schedule as required by the most recent ordinances of the City of Keller. A plan review fee equal to sixty-five percent (65%) of the construction permit fee will also apply.

P102.5 Fire alarm and detection systems and related equipment. The permit fee for the installation of or modification to fire alarm and detection systems and related equipment required by Section 105.7.7 shall be determined by the cost of construction and the fee shall be calculated based on the fee schedule as required by the most recent ordinances of the City of Keller. A plan review fee equal to sixty-five percent (65%) of the construction permit fee will also apply.

P102.6 Fire pumps and related equipment. The permit fee for the installation of or modification to fire pumps and related fuel tanks, jockey pumps, controllers, and generators required by Section 105.7.8 shall be determined by the cost of construction

and the fee shall be calculated based on the fee schedule as required by the most recent ordinances of the City of Keller. A plan review fee equal to sixty-five percent (65%) of the construction permit fee will also apply.

P102.7 Flammable and combustible liquids. The permit fee for the installation of or repair or modification to a pipeline, tank, or other such items required by Section 105.7.9 shall be determined by the cost of construction and the fee shall be calculated based on the fee schedule as required by the most recent ordinances of the City of Keller. A plan review fee equal to sixty-five percent (65%) of the construction permit fee will also apply.

P102.8 Hazardous materials. The permit fee for the installation, repair, abandonment, removal, closure, or modification to a storage facility or other area regulated by Chapter 50 as required by Section 105.7.13 shall be determined by the cost of construction and the fee shall be calculated based on the fee schedule as required by the most recent ordinances of the City of Keller. A plan review fee equal to sixty-five percent (65%) of the construction permit fee will also apply.

P102.9 Industrial ovens. The permit fee for the installation of industrial ovens covered by Chapter 30 as required by Section 105.7.15 shall be determined by the cost of construction and the fee shall be calculated based on the fee schedule as required by the most recent ordinances of the City of Keller. A plan review fee equal to sixty-five percent (65%) of the construction permit fee will also apply.

P102.10 LP-gas. The permit fee for the installation of or modification to an LP-gas system required by Section 105.7.16 shall be determined by the cost of construction and the fee shall be calculated based on the fee schedule as required by the most recent ordinances of the City of Keller. A plan review fee equal to sixty-five percent (65%) of the construction permit fee will also apply.

P102.11 Spraying or dipping. The permit fee for the installation of or modification to a spray room, dip tank or booth required by Section 105.7.23 shall be determined by the cost of construction and the fee shall be calculated based on the fee schedule as required by the most recent ordinances of the City of Keller. A plan review fee equal to sixty-five percent (65%) of the construction permit fee will also apply.

P102.12 Standpipe systems. The permit fee for the installation of, modification to or removal from service of a standpipe system required by Section 105.7.24 shall be determined by the cost of construction and the fee shall be calculated based on the fee schedule as required by the most recent ordinances of the City of Keller. A plan review fee equal to sixty-five percent (65%) of the construction permit fee will also apply.

P102.13 Smoke control or exhaust systems. The permit fee for the installation of or modification to a smoke control or exhaust system required by Section 105.7.20 shall be determined by the cost of construction and the fee shall be calculated based on the fee schedule as required by the most recent ordinances of the City of Keller. A plan review fee equal to sixty-five percent (65%) of the construction permit fee will also apply.

P102.14 Electronic access control systems. The permit fee for the installation of or modification to an electronic access control system as described in Section 105.7.26 shall be determined by the cost of construction and the fee shall be calculated based on the fee schedule as required by the most recent ordinances of the City of Keller. A plan review fee equal to sixty-five percent (65%) of the construction permit fee will also apply.

P102.15 Gates across fire lanes. A permit is required for the installation of controlled access gates across required fire lanes as described in Section 105.7.12. The permit fee for the installation of or modification to controlled access gates across required fire lanes shall be determined by the cost of construction and the fee shall be calculated based on the fee schedule as required by the most recent ordinances of the City of Keller. A plan review fee equal to sixty-five percent (65%) of the construction permit fee will also apply.

P102.16 Tent and Membrane Structures. The permit fee for the installation of a tent or membrane structure as described in Section 105.6.45 shall be determined by the cost of construction and the fee shall be calculated based on the fee schedule as required by the most recent ordinances of the City of Keller. A plan review fee equal to sixty-five percent (65%) of the construction permit fee will also apply.

P102.17 Fireworks Displays. A permit is required for the display of Fireworks as described in Section 5601.1.3 and Section 5608. The permit fee for fireworks displays shall be calculated based on the fee schedule as required by the most recent ordinances of the City of Keller. A plan review fee equal to sixty-five percent (65%) of the permit fee will also apply.

AMENDMENTS TO ORDINANCE 1807 RELATED TO BURNING

Proposed Changes:

Section 307.1.1; amend to read as follows:

Section 307.1.1 All open burning, including land clearing operations, prescribed burns and burning of domestic waste is prohibited in accordance with the following:

1. Texas Commission on Environmental Quality guidelines and/or restrictions.
2. State, County or Local temporary or permanent bans on open burning.
3. Chapter 382, Texas Clean Air Act

Section 307.2 shall be amended to read as follows:

Section 307.4.2; amend to read as follows:

307.4.2 Recreational fires. The fuel used for recreational burns shall consist of only clean seasoned firewood, natural gas or equivalent, or any clean burning fuel with emissions

that are equivalent to or lower than those created from the burning of seasoned firewood. Any resident wishing to kindle a recreational fire consisting of natural wood products, shall confirm the burn conditions at www.kellerfd.com prior to kindling. The burning of organic material is prohibited during State, County or Local temporary or permanent bans on outdoor burning.

Exemption:

Users of Compressed Natural Gas and Liquid Propane Gas fueled fire pits.

Container requirements:

1. The minimum required distance from a structure for an in-ground fire pit shall be 25 feet, and 15 feet for a portable fire pit.
2. Maximum diameter of 3 feet or less with firewood no greater than 2 feet or less in height/depth.

Section 307.5 Attendance; amend to read as follows:

307.5 Attendance. Recreational fires and use of portable outdoor fire pits shall be constantly attended until the fire is extinguished. A minimum of one portable fire extinguisher complying with Section 906 with a minimum 4-A rating or other approved on-site fire-extinguishing equipment, such as dirt, sand, water barrel, garden hose or water truck, shall be available for immediate utilization.

Section 307.6 create new section 307.6 Fire Pit Safety Survey to read as follows:

307.6 Fire Pit Safety Survey. Residents of the City of Keller electing to inform the fire department of their recreational fire location may submit the online Fire Pit Safety survey at www.kellerfd.com

Sec. 4-140. - Specific Amendments to the 2021 International Fuel and Gas Code (IFGC).

Section 102.2; add an exception to read as follows:

Exception: Existing dwelling units shall comply with Section 621.2.

Section 102.8; change to read as follows:

102.8 Referenced codes and standards. The codes and standards referenced in this code shall be those that are listed in Chapter 8 and such codes, when specifically adopted, and standards shall be considered

part of the requirements of this code to the prescribed extent of each such reference. Where differences occur between provisions of this code and the referenced standards, the provisions of this code shall apply. Whenever amendments have been adopted to the referenced codes and standards, each reference to said code and standard shall be considered to reference the amendments as well. Any reference to NFPA 70 or the *National Electrical Code* shall mean the Electrical Code as adopted.

Section 306.5; change to read as follows:

[M] 306.5 Equipment and Appliances on Roofs or Elevated Structures. Where *equipment* requiring *access* or appliances are located on an elevated structure or the roof of a building such that personnel will have to climb higher than 16 feet (4877 mm) above grade to access, an interior or exterior means of access shall be provided. Exterior ladders providing roof *access* need not extend closer than 12 feet (2438 mm) to the finish grade or floor level below and shall extend to the *equipment* and appliances' level service space. Such *access* shall . . . *{bulk of section to read the same}* . . . on roofs having a slope greater than four units vertical in 12 units horizontal (33-percent slope). ... *{remainder of text unchanged}*

Section 306.5.1; change to read as follows:

[M] 306.5.1 Sloped roofs. Where appliances, *equipment*, fans or other components that require service are installed on a roof having a slope of 3 units vertical in 12 units horizontal (25-percent slope) or greater and having an edge more than 30 inches (762 mm) above grade at such edge, a catwalk at least 16 inches in width with substantial cleats spaced not more than 16 inches apart shall be provided from the roof *access* to a level platform at the appliance. The level platform shall be provided on each side of the appliance to which *access* is required for service, repair or maintenance. The platform shall be not less than 30 inches (762 mm) in any dimension and shall be provided with guards. The guards shall extend not less than 42 inches (1067 mm) above the platform, shall be constructed so as to prevent the passage of a 21-inch-diameter (533 mm) sphere and shall comply with the loading requirements for guards specified in the *International Building Code*.

Section 401.5; add a second paragraph to read as follows:

Both ends of each section of medium pressure gas piping shall identify its operating gas pressure with an *approved* tag. The tags are to be composed of aluminum or stainless steel and the following wording shall be stamped into the tag:

"WARNING

1/2 to 5 psi gas pressure

Do Not Remove"

Section 404.12; change to read as follows:

404.12 Minimum burial depth. Underground piping systems shall be installed a minimum depth of ~~12~~ 18 inches (~~305~~ 458 mm) top of pipe below grade, except as provided for in Section 404.12.1.

404.12.1 Delete in its entirety.

Section 406.4; change to read as follows:

406.4 Test pressure measurement. Test pressure shall be measured with a monometer or with a pressure-measuring device designed and calibrated to read, record, or indicate a pressure loss caused by leakage during the pressure test period. The source of pressure shall be isolated before the pressure tests are made. Mechanical gauges used to measure test pressures shall have a range such that the highest end of the scale is not greater than five times the test pressure. Spring type gauges do not meet the requirement of a calibrated gauge.

Section 406.4.1; change to read as follows:

406.4.1 Test pressure. The test pressure to be used shall be no less than ~~1 1/2~~ times the proposed maximum working pressure, but no less than 3 3 psig (20 kPa gauge), or at the discretion of the Code Official, the piping and valves may be tested at a pressure of at least six (6) inches (152 mm) of mercury, measured with a manometer or slope gauge, irrespective of design pressure. Where the test pressure exceeds 125 psig (862 kPa gauge), the test pressure shall not exceed a value that produces a hoop stress in the piping greater than 50 percent of the specified minimum yield strength of the pipe. For tests requiring a pressure of 3 psig, diaphragm gauges shall utilize a dial with a minimum diameter of three and one half inches (3 1/2"), a set hand, 1/10 pound incrementation and pressure range not to exceed 15 psi for tests requiring a pressure of 3 psig. For tests requiring a pressure of 10 psig, diaphragm gauges shall utilize a dial with a minimum diameter of three and one-half inches (3 1/2"), a set hand, a minimum of 2/10 pound incrementation and a pressure range not to exceed 50 psi. For welded piping, and for piping carrying gas at pressures in excess of fourteen (14) inches water column pressure (3.48 kPa) (1/2 psi) and less than 200 inches of water column pressure (52.2 kPa) (7.5 psi), the test pressure shall not be less than ten (10) pounds per square inch (69.6 kPa). For piping carrying gas at a pressure that exceeds 200 inches of water column (52.2 kPa) (7.5 psi), the test pressure shall be not less than one and one-half times the proposed maximum working pressure.

Diaphragm gauges used for testing must display a current calibration and be in good working condition. The appropriate test must be applied to the diaphragm gauge used for testing.

Section 409.1; add Section 409.1.4 to read as follows:

409.1.4 Valves in CSST installations. Shutoff valves installed with corrugated stainless steel (CSST) piping systems shall be supported with an *approved* termination fitting, or equivalent support, suitable for the

size of the valves, of adequate strength and quality, and located at intervals so as to prevent or damp out excessive vibration but in no case greater than 12-inches from the center of the valve. Supports shall be installed so as not to interfere with the free expansion and contraction of the system's piping, fittings, and valves between anchors. All valves and supports shall be designed and installed so they will not be disengaged by movement of the supporting piping.

Section 410.1; add a second paragraph and exception to read as follows:

Access to regulators shall comply with the requirements for *access to appliances* as specified in Section 306.

Exception: A passageway or level service space is not required when the regulator is capable of being serviced and removed through the required attic opening.

Section 621.2; add exception as follows:

621.2 Prohibited use. One or more unvented room heaters shall not be used as the sole source of comfort heating in a dwelling unit.

Exception: Existing *approved* unvented heaters may continue to be used in dwelling units, in accordance with the code provisions in effect when installed, when *approved* by the Code Official unless an unsafe condition is determined to exist as described in Section 108.7.

Sec. 4-145. - Specific Amendments to the 2020 National Electric Code (NEC).

Article 100; add the following to definitions:

Engineering Supervision. Supervision by a Qualified State of Texas Licensed Professional Engineer engaged primarily in the design or maintenance of electrical installations.

Article 110.2; change the following to read as follows:

110.2 Approval. The conductors and equipment required or permitted by this *Code* shall be acceptable only if approved. Approval of equipment may be evident by listing and labeling of equipment by a Nationally Recognized Testing Lab (NRTL) with a certification mark of that laboratory or a qualified third party inspection agency or a field evaluation by a Field Evaluation Body accredited by either the International Code Council International Accreditation Service AC354 or ANSI National Accreditation Board programs and approved by the AHJ.

Exception: Unlisted equipment that is relocated to another location within a jurisdiction or is field modified is subject to the approval by the AHJ. This approval may be by a field evaluation by a NRTL or qualified third-party inspection agency or a field evaluation by a Field Evaluation Body accredited by either the ICC IAS AC354 or ANAB programs and approved by the AHJ

Manufacturer's self-certification of any equipment shall not be used as a basis for approval by the AHJ.

Informational Note No. 1: See 90.7, Examination of Equipment for Safety, and 110.3, Examination, Identification, Installation, and Use of Equipment. See definitions of *Approved*, *Identified*, *Labeled*, and *Listed*.

Informational Note No. 2: Manufacturer's self-certification of equipment may not necessarily comply with U.S. product safety standards as certified by an NRTL.

Informational Note No. 3: National Fire Protection Association (NFPA) 790 and 791 provide an example of an approved method for qualifying a third-party inspection agency.

Article 400.8 Field Identification Required: Change the following to read as follows

408.4 Field Identification Required.

(A) Circuit Directory or Circuit Identification.

Every circuit and circuit modification shall be legibly identified as to its clear, evident, and specific purpose or use. The identification shall include an approved degree of detail that allows each circuit to be distinguished from all others. Spare positions that contain unused overcurrent devices or switches shall be described accordingly. The identification shall be included in a circuit directory that is located on the face or inside of, or in an approved location adjacent *and permanently affixed* the panel door in the case of a panelboard and at each switch or circuit breaker in a switchboard or switchgear. No circuit shall be described in a manner that depends on transient conditions of occupancy.

Article 410.118: Change the following to read as follows

410.118 Access to other boxes.

Luminaires recessed in the ceilings, floors, or walls shall not be used to access outlet, pull, or junction boxes or conduit bodies, unless the box or conduit body is an integral part of the listed luminaire.

Exception: removable luminaires with a minimum measurement of 22 in. X 22 in. shall be permitted to be used as access to outlet, pull, junction boxes or conduit bodies.

Article 422.31 B: Change the following to read as follows

422.31 B Appliances Rated over 300 Volt-Amperes

(B) Appliances Rated over 300 Volt-Amperes. For permanently connected appliances rated over 300 volt-amperes, the branch-circuit switch or circuit breaker shall be permitted to serve as the disconnecting means where the switch or circuit breaker is within sight from *and is readily accessible to*

the appliance it serves or is capable of being locked in the open position in accordance with 110.25 and is readily accessible to the appliance it serves.

Informational Note No. 1: For appliances employing unit switches, see 422.34.

Informational Note No 2: The following means of access are considered to constitute readily accessible for this code change when conforming to the additional access requirements of the I Codes:

- (1) A permanent stair.
- (2) A pull-down stair with a minimum 300 lb. (136 kg) capacity.
- (3) An access door from an upper floor level.

Article 500.8 (A) (3); change to read as follows:

500.8 Equipment.

Articles 500 through 504 require equipment construction and installation that ensure safe performance under conditions of proper use and maintenance.

Informational Note No. 1: It is important that inspection authorities and users exercise more than ordinary care with regard to installation and maintenance.

Informational Note No. 2: Since there is no consistent relationship between explosion properties and ignition temperature, the two are independent requirements.

Informational Note No. 3: Low ambient conditions require special consideration. Explosion proof or dust-ignition proof equipment may not be suitable for use at temperatures lower than -25°C

(-13°F) unless they are identified for low-temperature service. However, at low ambient temperatures, flammable concentrations of vapors may not exist in a location classified as Class I, Division 1 at normal ambient temperature.

(A) Suitability. Suitability of identified equipment shall be determined by one of the following:

- (1) Equipment listing or labeling;
- (2) Evidence of equipment evaluation from a qualified testing laboratory or inspection agency concerned with product evaluation; or,
- (3) Evidence acceptable to the authority having jurisdiction such as a manufacturer's self-evaluation or an owner's engineering judgment, an engineering judgment signed and sealed by a qualified Registered licensed Professional Engineer in the State of Texas.

Informational Note: Additional documentation for equipment may include certificates demonstrating compliance with applicable equipment standards, indicating special conditions of use, and other pertinent information.

Article 505.7 (A) changed to read as follows:

505.7 Special Precaution.

Article 505 requires equipment construction and installation that ensures safe performance under conditions of proper use and maintenance.

Informational Note No. 1: It is important that inspection authorities and users exercise more than ordinary care with regard to the installation and maintenance of electrical equipment in hazardous (classified) locations.

Informational Note No. 2: Low ambient conditions require special consideration. Electrical equipment depending on the protection techniques described by 505.8(A) may not be suitable for use at temperatures lower than -20°C (-4°F) unless they are identified for use at lower temperatures. However, at low ambient temperatures, flammable concentrations of vapors may not exist in a location classified Class I, Zones 0, 1, or 2 at normal ambient temperature.

(A) Implementation of Zone Classification System. Classification of areas, engineering and design, selection of equipment and wiring methods, installation, and inspection shall be performed by a qualified person Registered licensed Professional Engineer in the State of Texas.

Article 695.6 A 1: Change the following to read as follows

695.6 (A) Supply Conductors.

(1) Services and On-Site Power Production Facilities.

Service conductors and conductors supplied by on-site power production facilities shall be physically routed outside a building(s) and shall be installed as service-entrance conductors in accordance with 230.6, 230.9, and Parts III and IV of Article 230. Where supply conductors cannot be physically routed outside of buildings, the conductors shall be permitted to be routed through the building(s) where installed in accordance with 230.6(1) or (2).

~~Exception: The supply conductors within the fire pump room shall not be required to meet 230.6 (1) or (2)~~

Article 71.15 A: Change the following to read as follows

710.15 General

710.15(A) Supply Output.

Power supply to premises wiring systems fed by stand-alone or isolated microgrid power sources shall be permitted to have less capacity than the calculated load. The capacity of the sum of all sources of the

stand-alone supply shall be equal to or greater than the load posed by the largest single utilization equipment connected to the system. Calculated general lighting loads shall not be considered as a single load have adequate capacity to meet the calculated load in accordance with Article 220.

Informational Note: For general-use loads the system capacity can be calculated using the sum of the capacity of the firm sources, such as generators and ESS inverters. For specialty loads intended to be powered directly from a variable source, the capacity can be calculated using the sum of the variable sources, such as PV or wind inverters, or the combined capacity of both firm and variable sources.

Sec. 4-150. - Specific Amendments to the 2021 International Plumbing Code (IPC).

Table of Contents, Chapter 7, Section 713; change to read as follows:

714-713 Engineered Computerized Drainage Design 69-7-12

Section 102.8; change to read as follows:

102.8 Referenced codes and standards. The codes and standards referenced in this code shall be those that are listed in Chapter 15 and such codes, when specifically adopted, and standards shall be considered as part of the requirements of this code to the prescribed extent of each such reference. Where the differences occur between provisions of this code and the referenced standards, the provisions of this code shall be the minimum requirements. Whenever amendments have been adopted to the referenced codes and standards, each reference to said code and standard shall be considered to reference the adopted amendments. Any reference to NFPA 70 shall mean the National Electrical Code as adopted.

Section 305; change to read as follows:

305.1 Protection against contact. Metallic piping, except for cast iron, ductile iron and galvanized steel, shall not be placed in direct contact with steel framing members, concrete or cinder walls and floors or other masonry. Metallic piping shall not be placed in direct contact with corrosive soil. Where sheathing is used to prevent direct contact, the sheathing shall have a thickness of not less than 0.008 inch (8 mil) (0.203 mm) and the sheathing shall be made of approved material plastic. Where sheathing protects piping that penetrates concrete or masonry walls or floors, the sheathing shall be installed in a manner that allows movement of the piping within the sheathing.

Section 305.4.1; changed to read as follows:

305.4.1 Sewer depth. ~~Building sewers that connect to private sewage disposal systems shall be a minimum of [number] inches (mm) below finished grade at the point of septic tank connection.~~ Building sewers shall be a minimum of 12 inches (304 mm) below grade.

Section 306.2.4; added to read as follows:

306.2.4 Plastic sewer and DWV piping installation. Plastic sewer and DWV piping installed underground shall be installed in accordance with the manufacturer's installation instructions. Trench width shall be controlled to not exceed the outside the pipe diameter plus 16 inches or in a trench which has a controlled width equal to the nominal diameter of the diameter of the piping multiplied by 1.25 plus 12 inches. The piping shall be bedded in 4 inches of granular fill and then backfilled compacting the side fill in 6-inch layers on each side of the piping. The compaction shall be to minimum of 85 percent standard proctor density and extend to a minimum of 6 inches above the top of the pipe.

Section 413.4; change to read as follows:

413.4 Required location for floor drains ~~Public laundries and central washing facilities.~~ Floor drains shall be installed in the following areas:

1. In public laundries and in the central washing facilities of multiple family dwellings, the rooms containing automatic clothes washers shall be provided with floor drains located to readily drain the entire floor area. Such drains shall have a minimum outlet of not less than 3 inches (76 mm) in diameter.
2. Commercial kitchens. In lieu of floor drains in commercial kitchens, the Code Official may accept floor sinks.
3. Public restrooms.

Section 608.17.5; change to read as follows:

608.17.5 Connections to lawn irrigation systems.

The potable water supply to lawn irrigation systems shall be protected against backflow by an atmospheric-type vacuum breaker, a pressure-type vacuum breaker, a double-check assembly or a reduced pressure principal backflow preventer. A valve shall not be installed downstream from an atmospheric vacuum breaker. Where chemicals are introduced into the system, the potable water supply shall be protected against backflow by a reduced pressure principal backflow preventer.

Section 703.6; Delete

Section 704.5; added to read as follows:

704.5 Single stack fittings. Single stack fittings with internal baffle, PVC schedule 40 or cast-iron single stack shall be designed by a registered engineer and comply to a national recognized standard.

Section 712.4.3; add Section 712.4.3 to read as follows:

712.4.3 Dual Pump System. All sumps shall be automatically discharged and, when in any “public use” occupancy where the sump serves more than 10 fixture units, shall be provided with dual pumps or ejectors arranged to function independently in case of overload or mechanical failure. For storm drainage sumps and pumping systems, see Section 1113.

Section 713, 713.1; change to read as follows:

SECTION 713

ENGINEERED COMPUTERIZED DRAINAGE DESIGN

713.1 Design of drainage system. The sizing, design and layout of the drainage system shall be permitted to be designed by a registered engineer using approved computer design methods.

Section 903.1.1; change to read as follows:

~~**903.1 Roof extension**~~ **903.1.1 Roof extension unprotected.** Open vent pipes that extend through a roof shall terminate not less than six (6) inches (152 mm) above the roof. ~~Where a roof is to be used for assembly or as a promenade, observation deck, sunbathing deck or similar purposes, open vent pipes shall terminate not less than 7 feet (2134 mm) above the roof.~~

Section 1109; delete this section.

Section 1202.1; delete Exceptions 1 and 2.

Sec. 4-155. - Specific Amendments to the 2021 International Mechanical Code (IMC).

Section 102.8; change to read as follows:

102.8 Referenced Codes and Standards. The codes and standards referenced herein shall be those that are listed in Chapter 15 and such codes, when specifically adopted, and standards shall be considered part of the requirements of this code to the prescribed extent of each such reference. Where differences occur between provisions of this code and the referenced standards, the provisions of this code shall apply. Whenever amendments have been adopted to the referenced codes and standards, each reference to

said code and standard shall be considered to reference the adopted amendments. Any reference to NFPA 70 shall mean the National Electrical Code as adopted.

Section 306.5; change to read as follows:

306.5 Equipment and Appliances on Roofs or Elevated Structures. Where *equipment* requiring *access* or appliances are located on an elevated structure or the roof of a building such that personnel will have to climb higher than 16 feet (4877 mm) above grade to access, an interior or exterior means of access shall be provided. Exterior ladders providing roof *access* need not extend closer than 12 feet (2438 mm) to the finish grade or floor level below and shall extend to the *equipment* and appliances' level service space. Such *access* shall . . . *{bulk of section to read the same}* . . . on roofs having a slope greater than four units vertical in 12 units horizontal (33-percent slope). ... *{remainder of text unchanged}*.

Section 306.5.1; change to read as follows:

306.5.1 Sloped Roofs. Where appliances, *equipment*, fans or other components that require service are installed on a roof having a slope of three units vertical in 12 units horizontal (25-percent slope) or greater and having an edge more than 30 inches (762 mm) above grade at such edge, a catwalk at least 16 inches in width with substantial cleats spaced not more than 16 inches apart shall be provided from the roof access to a level platform at the appliance. The level platform shall be provided on each side of the appliance to which *access* is required for service, repair or maintenance. The platform shall be not less than 30 inches (762 mm) in any dimension and shall be provided with guards. The guards shall extend not less than 42 inches (1067 mm) above the platform, shall be constructed so as to prevent the passage of a 21-inch-diameter (533 mm) sphere and shall comply with the loading requirements for guards specified in the *International Building Code*...*{remainder of text unchanged}*.

Section 501.3; add an exception to read as follows:

501.3 Exhaust Discharge. The air removed by every mechanical exhaust system shall be discharged outdoors at a point where it will not cause a public nuisance and not less than the distances specified in Section 501.3.1. The air shall be discharged to a location from which it cannot again be readily drawn in by a ventilating system. Air shall not be exhausted into an attic, crawl space, or be directed onto walkways.

Exceptions:

1. Whole-house ventilation-type attic fans shall be permitted to discharge into the attic space of dwelling units having private attics.
2. Commercial cooking recirculating systems.
3. Where installed in accordance with the manufacturer's instructions and where mechanical or natural ventilation is otherwise provided in accordance with Chapter 4, listed and labeled domestic ductless range hoods shall not be required to discharge to the outdoors.
4. Toilet room exhaust ducts may terminate in a warehouse or shop area when infiltration of outside air is present.

Sec. 4-160. - Specific Amendments to the 2018 International Energy Conservation Code (IECC).

Section C102/R102 General; add Section C102.1.2 and R102.1.2 (N1101.4.1) to read as follows:

C102.1.2 Alternative compliance. A building certified by a national, state, or local accredited energy efficiency program and determined by the Energy Systems Laboratory to be in compliance with the energy efficiency requirements of this section may, at the option of the Code Official, be considered in compliance. The United States Environmental Protection Agency's Energy Star Program certification of energy code equivalency shall be considered in compliance.

R102.1.2 (N1101.4.1) Alternative compliance. A building certified by a national, state, or local accredited energy efficiency program and determined by the Energy Systems Laboratory to be in compliance with the energy efficiency requirements of this section may, at the option of the Code Official, be considered in compliance. The United States Environmental Protection Agency's Energy Star Program certification of energy code equivalency shall be considered in compliance. Regardless of the program or the path to compliance, each 1- and 2-family dwelling shall be tested for air and duct leakage as prescribed in Section R402.4.1.2 (N1102.4.1.2) and R403.3.3 (N1103.3.3) respectively.

Section R202 (N1101.6) Definitions; add the following definition:

****PROJECTION FACTOR.** The ratio of the horizontal depth of the overhang, eave or permanently attached shading device, divided by the distance measured vertically from the bottom of the fenestration glazing to the underside of the overhang, eave or permanently attached shading device.

Section R202 (N1101.6) Definitions; add the following definition:

****DYNAMIC GLAZING.** Any fenestration product that has the fully reversible ability to change its performance properties, including *U*-factor, solar heat gain coefficient (SHGC), or visible transmittance (VT).

Table 402.1.2 (N1102.1.2) INSULATION AND FENESTRATION REQUIREMENTS BY COMPONENT; the Fenestration *U*-factor for Climate Zone 3 is amended as follows:

CLIMATE	FENESTRATION
---------	--------------

ZONE	U-FACTOR
3	0.32 <u>0.35</u>

Section R402.3.2 (N1102.3.2) Glazed fenestration SHGC; amend by adding a paragraph and table following the exception to read as follows:

Where vertical fenestration is shaded by an overhang, eave, or permanently attached shading device, the SHGC required in Table R402.1.2 shall be reduced by using the multipliers in Table R402.3.2 SHGC Multipliers for Permanent Projections.

Table R402.3.2 SHGC Multipliers for Permanent Projections ^a

Projection Factor	SHGC Multiplier (all Other Orientation)	SHGC Multiplier (North Oriented)
0 - 0.10	1.00	1.00
>0.10 – 0.20	0.91	0.95
>0.20 – 0.30	0.82	0.91
>0.30 – 0.40	0.74	0.87
>0.40 – 0.50	0.67	0.84
>0.50 – 0.60	0.61	0.81
>0.60 – 0.70	0.56	0.78
>0.70 – 0.80	0.51	0.76
>0.80 – 0.90	0.47	0.75
>0.90 – 1.00	0.44	0.73

^a North oriented means within 45 degrees of true north.

R402.4.1.2 (N1102.4.1.2) Testing; add a last paragraph to read as follows:

Mandatory testing shall only be performed by individuals that are certified to perform air infiltration testing certified by national or state organizations as approved by the building official. The certified individuals must be an independent third-party entity, and may not be employed; or have any financial interest in the company that constructs the structure.

Section R402.4 (N1102.4) Air leakage (Mandatory); add a new section and table to read as follows:

R402.4.1.3 (N1102.4.1.3) Testing option – ACH tradeoff. As an option to the air leakage rate set out in Section R402.4.1.2 (N1102.4.1.2), 1- and 2-family homes meeting all of the listed criteria below and the *thermal envelope* requirements in Table R402.4.1.3 (N1102.4.1.3) will be considered compliant when tested and verified as having an air leakage rate to not less than or equal to four air changes per hour when tested and reported in accordance with the testing standards and reporting criteria listed in Section R402.4.1.2 (N1102.4.1.2).

The compliance equivalency is limited as follows:

1. Limited to a conditioned floor area between 1,000 and 6,000 square feet,
2. Limited to between 2 to 6 bedrooms,
3. Assumes all ductwork and mechanical equipment is located in the unconditioned attic,
4. Assumes typical wood framing in the walls and roof, and
5. Assumes one of the following heating/cooling systems:
 - a. All electric system with a heat pump for heating, or
 - b. A system with electric cooling and natural gas heating.

Dwellings using electric resistance strip heating do not qualify for this tradeoff.

TABLE R402.4.1.3 (N1102.4.1.3)^a

Envelope Component	Option #1	Option #2
R402.4 Air Leakage	≤ 4 ACH50	≤ 4 ACH50
Wall Insulation <i>R</i> -value	R13 + R3 ^b	R13 + R3 ^b
Fenestration <i>U</i> -factor	≤ 0.32	≤ 0.32
Fenestration SHGC	≤ 0.25	≤ 0.25
Ceiling <i>R</i> -value	≥ R49	≥ R49
Duct Insulation <i>R</i> -value	R8	R6
Radiant Barrier Required	No	Yes

^a Except for the values listed in the table, all other mandatory code provisions are applicable.

^b The first value listed is the *R*-value of cavity insulation, the second value is the *R*-value of the continuous insulation or insulated siding.

Section R402.4 Air leakage (Mandatory); add a new section to read as follows:

R402.4.1.4 Testing options for R2 multifamily dwelling units. As an option to the air leakage rate set out in Section R402.4.1.2, multifamily dwelling units will be considered compliant when tested and verified as having an air leakage rate to the air leakage rate set out in either Section R402.4.1.4.1 or Section R402.4.1.4.2 when tested and reported in accordance with the testing standards and reporting criteria listed in Section R402.4.1.2

R402.4.1.4.1 Total air leakage rate for interior multifamily dwelling units. Interior multifamily dwelling units with a measured, “unguarded” total air leakage result of 5.3 ACH50 or less shall be considered compliant.

R402.4.1.4.2 Total air leakage rate for corner multifamily dwelling units. Corner multifamily units with a measured, “unguarded” total leakage result of less than 5.0 ACH50 shall be considered compliant.

Section R402.4 Air leakage (Mandatory); add a new section to read as follows:

R402.4.1.5 Sampling options for R2 multifamily dwelling units. For buildings having three or more

dwelling units, a minimum of 15% of the dwelling units in each building must be tested as required by Section R402.4.1.2. Prior to beginning sampling for testing, “Initial Testing” is required for each multifamily property. “Initial Testing” shall consist of the 3rd party testing contractor performing the required tests on at least three consecutive dwelling units. Test results from the “Initial Testing” must satisfy minimum code requirements before sampling is permitted. Dwelling units selected for the “Initial Testing” must be within the same building. Dwelling units selected for “Initial Testing” shall not be included in a “sample group” or counted toward the minimum 15% of dwelling units tested. The building official shall randomly select the three dwelling units for “Initial Testing.” The building official may delegate the random selection to the designated 3rd party testing contractor.

R402.4.1.5.1 Sample group Identification and Sampling. The builder shall identify a “sample group” which may be a building, floor, fire area or portion thereof. All of the dwelling units within the “sample group” must be at the same stage of construction and must be ready for testing. The building official shall randomly select at least 15% of dwelling units from each “sample group” for testing. The building official may delegate the random selection to the designated 3rd party testing contractor.

If each tested dwelling unit within a “sample group” meets the minimum code requirements, then all dwelling units in the “sample group” are considered to meet the minimum code requirements.

Before a building may be deemed compliant with the testing as required, each “sample group” must be deemed compliant with the minimum code requirements. The sum total of all of the tested dwelling units across all “sample groups” shall not be less than a minimum of 15% of the dwelling units in a building.

R402.4.1.5.2 Failure to Meet Code Requirement(s). If any dwelling units within the identified “sample group” fail to meet a code requirement as determined by testing, the builder will be directed to correct the cause(s) of failure, and 30% of the remaining dwelling units in the “sample group” will be randomly selected for testing by the building official, or third-party testing contractor, regarding the specific cause(s) of failure.

If any failures occur in the additional dwelling units, all remaining dwelling units in the sample group must be individually tested for code compliance.

A multifamily property with three failures within a 90-day period is no longer eligible to use the sampling protocol in that community or project until successfully repeating "Initial Testing." Sampling may be reinstated after at least three consecutive dwelling units are individually verified to meet all code requirements.

A Certificate of Occupancy may not may be issued for any building until testing has been performed and deemed to satisfy the minimum code requirements on the dwelling unit(s) identified for testing.

R403.3.3 (N1103.3.3) Duct Testing (Mandatory); add a last paragraph to read as follows:

Mandatory testing shall only be performed by individuals that are certified to perform duct testing leakage testing certified by national or state organizations as approved by the building official. The certified individuals must be an independent third-party entity, and may not be employed; or have any financial interest in the company that constructs the structure.

Section R403.3 Ducts; add a new section to read as follows:

R403.3.4.1 Sampling options for R2 multifamily dwelling units. For buildings having three or more dwelling units, a minimum of 15% of the dwelling units in each building must be tested as required by Section R403.3.3. Prior to beginning sampling for testing, "Initial Testing" is required for each multifamily property. "Initial Testing" shall consist of the 3rd party testing contractor performing the required tests on at least three consecutive dwelling units. Test results from the "Initial Testing" must satisfy minimum code requirements before sampling is permitted. Dwelling units selected for the "Initial Testing" must be within the same building. Dwelling units selected for "Initial Testing" shall not be included in a "sample group" or counted toward the minimum 15% of dwelling units tested. The building official shall randomly select the three dwelling units for "Initial Testing." The building official may delegate the random selection to the designated 3rd party testing contractor.

R403.3.4.1.1 Sample group Identification and Sampling. The builder shall identify a "sample group" which may be a building, floor, fire area or portion thereof. All of the dwelling units within the "sample group" must be at the same stage of construction and must be ready for testing. The building official shall randomly select at least 15% of dwelling units from each "sample group" for testing. The building official may delegate the random selection to the designated 3rd party testing contractor.

If each tested dwelling unit within a “sample group” meets the minimum code requirements, then all dwelling units in the “sample group” are considered to meet the minimum code requirements.

Before a building may be deemed compliant with the testing as required, each “sample group” must be deemed compliant with the minimum code requirements. The sum total of all of the tested dwelling units across all “sample groups” shall not be less than a minimum of 15% of the dwelling units in a building.

R403.3.4.1.2 Failure to Meet Code Requirement(s). If any dwelling units within the identified “sample group” fail to meet a code requirement as determined by testing, the builder will be directed to correct the cause(s) of failure, and 30% of the remaining dwelling units in the “sample group” will be randomly selected for testing by the building official, or third-party testing contractor, regarding the specific cause(s) of failure.

If any failures occur in the additional dwelling units, all remaining dwelling units in the sample group must be individually tested for code compliance.

A multifamily property with three failures within a 90-day period is no longer eligible to use the sampling protocol in that community or project until successfully repeating "Initial Testing." Sampling may be reinstated after at least three consecutive dwelling units are individually verified to meet all code requirements.

A Certificate of Occupancy may not may be issued for any building until testing has been performed and deemed to satisfy the minimum code requirements on the dwelling unit(s) identified for testing.

Section C402.2/R402.2 (N1102.2) Specific insulation requirements (Prescriptive); add Section C402.2.8 and R402.2.14 (N1102.2.14) to read as follows:

Section C402.2.8/R402.2.14 (N1102.2.14) Insulation installed in walls. Insulation installed in walls shall be totally enclosed on all sides consisting of framing lumber, gypsum, sheathing, wood structural panel sheathing or other equivalent material approved by the building official.

Section C403.7.4 Energy recovery ventilation systems (Mandatory); add exception #12 to read as follows:

12. Individual ventilation systems that serve an individual dwelling unit or sleeping unit.

Section C403.11.1 Duct and Plenum Insulation and Sealing (Mandatory); is amended by adding a second paragraph to read as follows:

Environmental ducts and plenums installed in vertical chases, both supply and exhaust, where the ducts or plenums will not be accessible after construction completion, shall be leak tested in accordance with the SMACNA HVAC Air Leakage Test Manual to the installed ductwork class and pressure requirements.

Documentation shall be furnished demonstrating that representative sections totaling not less than 25 percent of the duct area have been tested and that all tested sections comply with the requirements of this section.

Section R404.1 (N1104.1); revised in its entirety to read as follows:

Section R404.1 (N1104.1) Lighting equipment (Mandatory). Not less than 75 percent of the lamps in permanently installed lighting fixtures or not less than 75 percent of the permanently installed lighting fixtures shall contain only high-efficacy lamps.

Section 405.2 (N1105.2); add the exception to read as follows:

Section 405.2 (N1105.2) Mandatory requirements. Compliance with the section requires that the mandatory provisions identified in Section 401.2 be met. Supply and return ducts not completely inside the building thermal envelope shall be insulated to an R-value of not less than R-6.

Exceptions:

1. For one and two family dwellings the maximum envelope leakage of 4 ACH50 is permitted provided the envelope leakage in the Standard Reference Design is 3 ACH50 and all other requirements of Section R405 are met, including all other mandatory measures. The annual energy cost or source energy usage of the Proposed Design must be equal to or less than that of the Standard Reference Design.
2. For multifamily or townhomes and buildings classified as Group R2 and Group R4 of three stories or less the maximum envelope leakage of less than 5 ACH50 is permitted provided the envelope leakage in the Standard Reference Design is 3 ACH50 and all other requirements of Section R405 are met, including all other mandatory measures. The annual energy cost or source energy usage of the Proposed Design must be equal to or less than that of the Standard Reference Design.

Section R405.6.2 (N1105.6.2); add the following sentence to the end of paragraph:

Acceptable performance software simulation tools may include, but are not limited to, REM Rate™; Energy Gauge®; ICF International Beacon Residential; Ekotrope, HERS Module; Right-Energy HERS and IC3. Other performance software programs as listed by RESNET® and having the ability to provide a report as outlined in R405.4.2 may also be deemed acceptable performance simulation programs and may be considered by the building official.

Section C405.9. Voltage drop in feeders; deleted in its entirety.

TABLE R406.4 (N1106.4) MAXIMUM ENERGY RATING INDEX; amend to read as follows:

**TABLE R406.4 (N1106.4) ¹
MAXIMUM ENERGY RATING INDEX**

CLIMATE ZONE	ENERGY RATING INDEX
3	65

¹ This table is effective until August 31, 2019.

**TABLE R406.4 (N1106.4) ²
MAXIMUM ENERGY RATING INDEX**

CLIMATE ZONE	ENERGY RATING INDEX
3	63

² The table is effective from September 1, 2019 to August 31, 2022.

**TABLE R406.4 (N1106.4) ³
MAXIMUM ENERGY RATING INDEX**

CLIMATE ZONE	ENERGY RATING INDEX
3	59

³ This table is effective on or after September 1, 2022.

Section C408.3.1 Functional Testing; amend to read as follows:

C408.3.1 Functional Testing. Prior to passing final inspection, the *registered design professional* or *approved agency* shall provide evidence that the lighting control systems have been tested to ensure that control hardware and software are calibrated, adjusted, programmed, and in proper working condition in accordance with the *construction documents* and manufacturer’s instructions. Functional testing shall be in accordance with Sections C408.3.1.1 through C408.3.1.3 for the applicable control type.

Sec. 4-165. - Specific Amendments to the 2021 International Existing Building Code (IEBC).

Section 102.4; change to read as follows:

[A] 102.4 Referenced codes and standards. The codes, when specifically adopted, and standards referenced in this code shall be considered part of the requirements of this code to the prescribed extent of each such reference and as further regulated in Sections 102.4.1 and 102.4.2. {No change to rest of section.}

Section 110.2; delete number 11 as follows:

~~**11. Where an automatic sprinkler system is provided, and whether an automatic sprinkler system is required.**~~

Section 202; amend definition of Existing Building as follows:

Existing Building - A building, structure, or space with an approved final inspection issued under a code edition which is at least 2 published code editions preceding the currently adopted building code; a building, structure or space that is undergoing a change of occupancy or use. erected prior to the date of adoption of the appropriate code, or one for which a legal building permit has been issued.

Section 202; amend definition of Existing Structure as follows:

Existing Structure- A building, structure, or space, with an approved final inspection issued under a code edition which is at least 2 published code editions preceding the currently adopted building code; a building, structure or space that is undergoing a change of occupancy or use. erected prior to the date of adoption of the appropriate code, or one for which a legal building permit has been issued.

Section 306.1; add exceptions to read as follows:

Exceptions:

- 1. Components of projects regulated by and registered with Architectural Barriers Division of Texas Department of Licensing and Regulation shall be deemed to be in compliance with the requirements of this chapter.**
- 2. If the cost of the project is less than \$50K, it must comply with ICC A117.1, or it shall be reviewed and inspected to the Texas Accessibility Standards by a Registered Accessibility Specialist.**

Section 306.2; add exception to read as follows:

Exception: Projects subject to the Texas Accessibility Standards as adopted by the Texas Department of Licensing and Regulation are exempt from this section. Projects with a valuation of less than \$50,000.00 (which are subject to the Texas Accessibility Standards) may be accepted as equivalent to this section where reviewed and inspected to the Texas Accessibility Standards by a Texas Department of Licensing and Regulation Registered Accessibility Specialist when a plan review report and a compliant inspection report are provided to the building code official.

Section 306.5.1; add to read as follows:

306.5.1 Complete change of occupancy. Where an entire building undergoes a *change of occupancy*, it shall comply with Section 305.4.1 and shall have all of the following accessible features:

1. Not fewer than one accessible building entrance.
2. Not fewer than one accessible route from an accessible building entrance to *primary function areas*.
3. Signage complying with Section 1111 of the *International Building Code*.
4. Accessible parking, where parking is being provided.
5. Not fewer than one accessible passenger loading zone, where loading zones are provided.
6. Not fewer than one accessible route connecting accessible parking and accessible passenger loading zones to an accessible entrance.
7. At least one accessible family or assisted use toilet room shall be provided in accordance with Chapter 11 of the International Building Code.

Where it is *technically infeasible* to comply with the new construction standards for any of these requirements for a change of group or occupancy, Items 1 through 6 shall conform to the requirements to the maximum extent technically feasible.

Exception: The accessible features listed in Items 1 through 6 are not required for an accessible route to Type B units.

Section 401.3 Flood Hazard Areas; delete this section.

Section 406.1; add a code reference to read as follows:

406.1 Material. Existing electrical wiring and equipment undergoing *repair* shall be allowed to be repaired or replaced with like material, in accordance with the requirements of NFPA 70.

Section 502.3 Flood Hazard Areas; delete this section.

Section 503.16; add exception to read as follows:

Exception: Compliance with the Texas Accessibility Standards is not considered equivalent compliance for the purpose of enforcement of this code section.

Section 504.1.3; delete this section:

~~**504.1.3 New fire escapes.** New fire escapes for existing buildings shall be permitted only where exterior stairways cannot be utilized due to lot lines limiting stairway size or due to the sidewalks, alleys, or roads at grade level. New fire escapes shall not incorporate ladders or access by windows.~~

Section 507.3 Flood Hazard Areas; delete this section.

Section 701.3 Flood Hazard Areas; delete this section.

Section 702.4; add exception 2 to read as follows:

2. Operable windows with openings that are provided with window fall prevention devices that comply with ASTM F2090.

Section 702.7; add a code reference to read as follows:

702.7 Materials and methods. All new work shall comply with the materials and methods requirements in the *International Building Code*, *International Energy Conservation Code*, *International Mechanical Code*, *National Electrical Code*, and *International Plumbing Code*, as applicable, that specify material standards, detail of installation and connection, joints, penetrations, and continuity of any element, component, or system in the building.

Section 802.5.1; change to read as follows:

802.5.1 Minimum requirement. Every portion of a floor, ~~such as a balcony or a loading dock,~~ open-sided walking surfaces, including mezzanines, equipment platforms, aisles, stairs, ramps, and landings that is more than 30 inches (762 mm) above the floor or grade below and is not provided with guards, or those in which the existing guards are judged to be in danger of collapsing, shall be provided with guards.

Section 803.1; add sentence to read as follows:

For the purpose of fire sprinkler protection and fire alarm requirements included in this section, the work area shall be extended to include at least the entire tenant space or spaces bounded by walls capable of resisting the passage of smoke containing the subject work area, and if the work area includes a corridor, hallway, or other exit access, then such corridor, hallway, or other exit access shall be protected in its entirety on that particular floor level.

Section 803.2.6; change exception to read as follows:

Exception: Supervision is not required where the Fire Code does not require such for new construction. ~~for the following:~~

- ~~1. Underground gate valve with roadway boxes.~~
- ~~2. Halogenated extinguishing systems.~~
- ~~3. Carbon dioxide extinguishing systems.~~
- ~~4. Dry and wet chemical extinguishing systems.~~
5. Automatic sprinkler systems installed in accordance with NFPA 13R where a common supply main is used to supply both domestic and automatic sprinkler systems and a separate shutoff valve for the automatic sprinkler system is not provided.

Section 803.3; change section to read as follows:

803.3 Standpipes. Refer to Section 1103.6 of the Fire Code for retroactive standpipe requirements.

~~{Delete rest of Section 803.3.}~~

Section 804.2; delete Exception #1 as follows:

Exceptions: ~~1. Where the work area and the means of egress serving it complies with NFPA101.~~

- ~~2. [Remain unchanged]~~

Section 804.4.1.2; change to read as follows:

804.4.1.2 Fire Escapes required. For other than Group I-2, where more than one exit is required, an existing ~~or newly constructed~~ fire escape complying with section 805.3.1.2.1 shall be accepted as providing one of the required means of egress.

Section 804.4.1.2.1; change to read as follows:

804.4.1.2.1 Fire Escape access and details -

1. [Remain unchanged]
2. Access to a new fire escape shall be through a door...
- ~~3. Newly constructed fire escapes shall be permitted only where exterior stairways cannot be utilized because of lot lines limiting the stairway size or because of the sidewalks, alleys, or roads at grade level.~~
4. [Remain unchanged]
5. In all buildings of Group E occupancy up to and including the 12th grade, buildings of Group I occupancy, ~~rooming~~ boarding houses, and childcare centers, ladders of any type are prohibited on fire escapes used as a required means of egress.

Section 804.6.2 Transoms; add language to read as follows:

804.6.2 Transoms. In all buildings of Group B, E, I-1, I-2, R-1 and R-2 occupancies,[Remainder unchanged]

Section 904.1; add sentence to read as follows:

For the purpose of fire sprinkler protection and fire alarm requirements included in this section, the work area shall be extended to include at least the entire tenant space or spaces bounded by walls containing the subject work area, and if the work area includes a corridor, hallway, or other exit access, then such corridor, hallway, or other exit access shall be protected in its entirety on that particular floor level.

Section 904.1.1; change to read as follows:

904.1.1 High-rise buildings. An automatic sprinkler system shall be provided in work areas ~~of~~ where the high-rise buildings. ~~has a sufficient municipal water supply for the design and installation of an automatic sprinkler system at the site.~~

Section 1011.2.1: change to read as follows:

1011.2.1 Fire sprinkler system. Where a change in occupancy classification occurs or where there is a *change of occupancy* within a space where there is a different fire protection system threshold requirement in Chapter 9 of the *International Building Code* that requires an automatic fire sprinkler system to be provided based on the new occupancy in accordance with Chapter 9 of the *International Building Code*. The installation of the automatic sprinkler system shall be required within the area of the *change of occupancy* and areas of the building not separated horizontally and vertically from the *change of occupancy* by one of the following:

- ~~1. Nonrated permanent partition and horizontal assemblies.~~
- ~~2. Fire partition.~~
- ~~3. Smoke partition.~~
- ~~4. Smoke barrier.~~
5. Fire barrier, as required by Section 707 of the IBC.
6. Fire wall, as required by Section 706 of the IBC.

Exceptions: [Remain unchanged.]

Section 1102.2.1; add to read as follows:

1102.2.1 Fire Separations. **Where fire separations are utilized to allow additions without exceeding the allowable area provisions of Chapter 5 of the IBC for either the existing building or the new addition, the decreased clear space where the two buildings adjoin shall be accounted for in such calculation relative to the allowable frontage increase.**

Section 1103.3 Flood Hazard Areas; delete this section.

Section 1301.3.2; change to read as follows:

1301.3.2 Compliance with other codes. Buildings that are evaluated in accordance with this section shall comply with the International Fire Code. ~~and International Property Maintenance Code.~~

Section 1301.3.3 Compliance with Flood Hazard Provisions; delete this section.

Section 1402.6 Flood Hazard Areas; delete this section.

Section 1509; delete Section 1509.1 through 1509.5 and add Section 1509.1 to read as follows:

1509.1 When required. An approved water supply for fire protection, either temporary or permanent, shall be made available as soon as combustible material arrives on the site. The water supply design and the timing of the water supply installation relative to building construction shall comply with the adopted Fire Code.

Sec. 4-170. - Specific Amendments to the 2021 International Swimming Pool and Spa Code (ISPSC).

Section 102.9; Change to read as follows:

Section 102.9 Other laws. The provisions of this code shall not be deemed to nullify any provisions of local, state or federal law, to include but not limited to:

1. Texas Department of State Health Services (TDSHS); *Standards for Public Pools and Spas*; §285.181 through §285.208, (TDSHS rules do not apply to pools serving one- and two-family dwellings or townhouses).
2. Texas Department of Licensing and Regulation (TDLR); *2012 Texas Accessibility Standards (TAS)*, TAS provide the scoping and technical requirements for accessibility for Swimming Pool, wading pools and spas and shall comply with *2012 TAS, Section 242*. (TAS rules do not apply to pools serving one- and two-family dwellings or townhouses).

Exception: Elements regulated under Texas Department of Licensing and Regulation (TDLR) and built in accordance with TDLR approved plans, including any variances or waivers granted by the TDLR, shall be deemed to be in compliance with the requirements of this Chapter.

Section 113.4 Violation penalties; *Changed to read as follows:*

113.4 Violation penalties. Any person who shall violate a provision of this code or shall fail to comply with any of the requirements thereof or who shall erect, install, alter or repair a pool or spa in violation of the *approved* construction documents or directive of the *code official*, or of a permit or certificate issued under the provisions of this code may be punishable for each day of the violation set forth by the *authority having jurisdiction*. ~~shall be guilty of a [SPECIFY OFFENSE], punishable by a fine of not more than [AMOUNT] dollars or by imprisonment not exceeding [NUMBER OF DAYS], or both such a fine and imprisonment. Each day that a violation continues after due notice has been served shall be deemed a separate offense.~~

Section 305; Change to read as follows:

305.1 General.

The provisions of this section shall apply to the design of barriers for restricting entry into areas having pools and spas. In only one-and two-family dwellings and townhouses, where spas or hot tubs are equipped with a lockable safety cover complying with ASTM F1346 and swimming pools are equipped with a powered safety cover that complies with ASTM F1346, the areas where those spas, hot tubs or pools are located shall not be required to comply with Sections 305.2 through 305.7.

Add subsection 305.2.7.1; to read as follows:

305.2.7.1 Chain link fencing prohibited. Chain link fencing is not permitted as a barrier in public pools built after January 1, 1994.

Section 305.4 structure wall as a barrier; Changes as follows:

305.4 Structure wall as a barrier. Where a wall of a dwelling or structure of a one- and two-family dwelling or townhouse or its accessory structure serves as part of a barrier and where doors or windows provide direct access to the pool or spa through that wall, one of the following shall be required:

1. Remainder Unchanged
2. Remainder Unchanged
3. Remainder Unchanged
4. Remainder unchanged
5. Remainder unchanged
6. Remainder unchanged

Section 305.6; Change to read as follows:

305.6 Natural barriers used in a one- and two-family dwelling or townhouse. In the case where the pool or spa area abuts the edge of a lake or other natural body of water, public access is not permitted or allowed along the shoreline, and required barriers extend to and beyond the water's edge a minimum of

eighteen (18) inches, a barrier is not required between the natural body of water shoreline and the pool or spa.

Section 307.1.4 Accessibility; Add exception to Section to 307.1.4 as follows:

Exception: Components of projects regulated by and registered with Architectural Barriers Division of Texas Department of Licensing and Regulation shall be deemed to be in compliance with the requirements of this chapter.

Section 307.2.2.2; add to read as follows:

Section 307.2.2.2. Adjacency to Structural Foundation. Depth of the swimming pool and spa shall maintain a ratio of 1:1 from the nearest building foundation or footing of a retaining wall.

Exception:

A sealed engineered design drawing of the proposed new structure shall be submitted for approval.

Section 310; Change to read as follows:

310.1 General. Suction entrapment avoidance for pools and spas shall be provided in accordance with APSP 7 (ANSI/PHTA/ICC 7) or for public swimming pools in accordance with State of Texas Rules for Public Swimming Pools and Spas, Title 25 TAC Chapter 265 Subchapter L, Rule §265.190.

Section 402.12; Change to read as follows:

402.12 Water envelopes. The minimum diving water envelopes shall be in accordance with ~~Table 402.12 Texas department of State Health services, Administrative Code Title 25, Chapter 265, Section 186 (e) and Figure: 25 TAC 256.186 (e) (6).~~ (Delete Table 402.12 and Figure 402.12)

ADD: Figure: 25 TAC §265.186 (e) (6)

Maximum Diving Board Height Over Water	¾ Meter	1 Meter	3 Meters
Max. Diving Board Length	12 ft.	16 ft.	16 ft.
Minimum Diving Board Overhang	2 ft. 6 in.	5 ft.	5 ft.

D1 Minimum	8 ft. 6 in.	11 ft. 2 in.	12 ft. 2 in.
D2 Minimum	9 ft.	10 ft. 10 in.	11 ft. 10 in.
D3 Minimum	4 ft.	6 ft.	6 ft.
L1 Minimum	4 ft.	5 ft.	5 ft.
L2 Minimum	12 ft.	16 ft. 5 in.	19 ft. 9 in.
L3 Minimum	14 ft. 10 in.	13 ft. 2 in.	13 ft. 11 in.
L4 Minimum	30 ft. 10 in.	34 ft. 7 in.	38 ft. 8 in.
L5 Minimum	8 ft.	10 ft.	13 ft.
H Minimum	16 ft.	16 ft.	16 ft.
From Plummet to Pool Wall at Side	9 ft.	10 ft.	11 ft. 6 in.
From Plummet to Adjacent Plummet	10 ft.	10 ft.	10 ft.

H (Overhead
Obstruction or Ceiling)

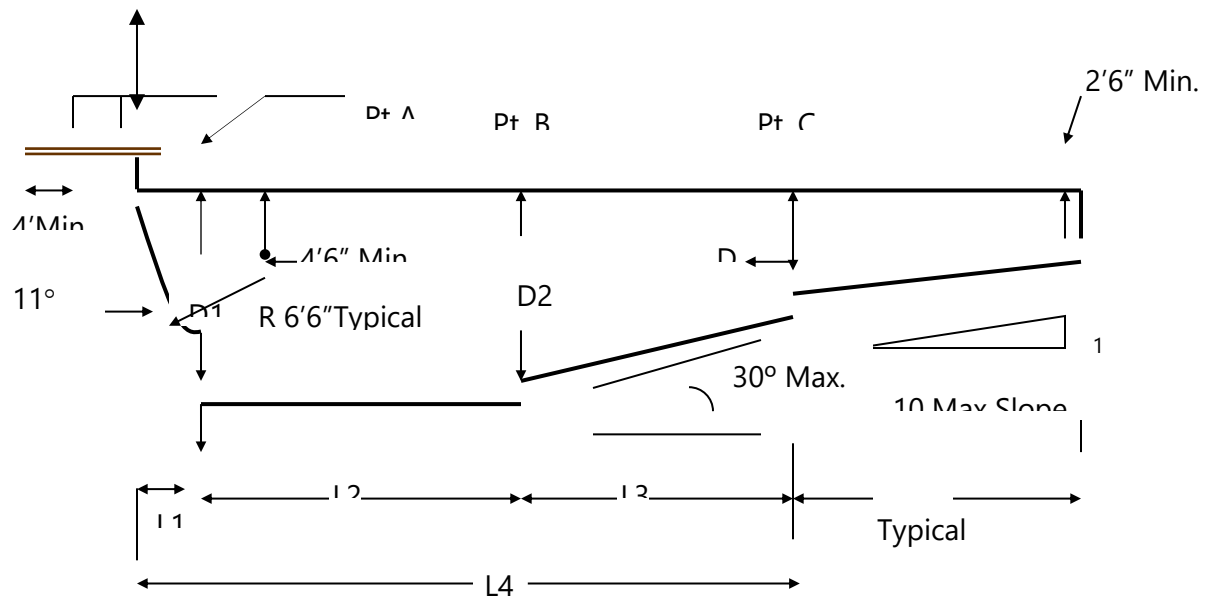

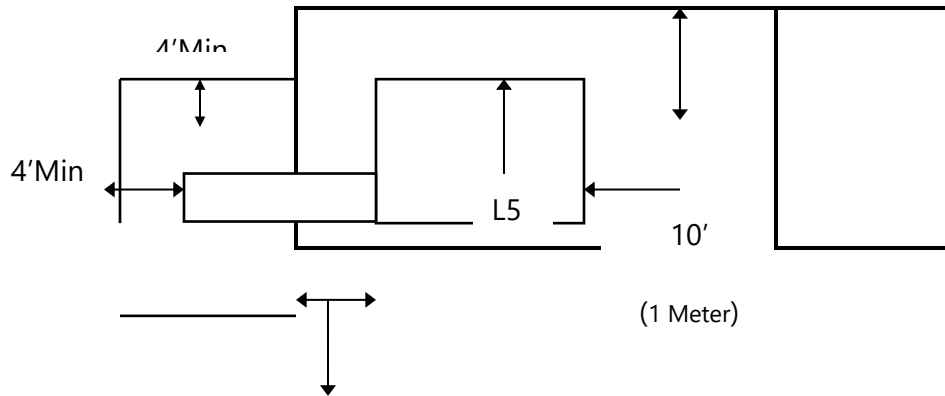

Section 411.2.1 & 411.2.2; Change to read as follows:

411.2.1 Tread dimensions and area. Treads shall have a minimum unobstructed horizontal depth (i.e., horizontal run) of 12 inches and a minimum width of 20 inches, not be less than 24 inches (607mm) at the leading edge. Treads shall have an unobstructed surface area of not less than 240 square inches (154838mm²) and an unobstructed horizontal depth of not less than 10 inches (254 mm) at the center line.

411.2.1 Risers. Risers for steps shall have a maximum uniform height of 10 inches, with the bottom riser height allowed to taper to zero except for the bottom riser, shall have a uniform height of not greater than 12 inches (305 mm) measured at the center line. The bottom riser height is allowed to vary to the floor.

Section 411.5.1 & 411.5.2; Change to read as follows:

411.5.1 Swimouts. Swimouts, located in either the deep or shallow area of a pool, shall comply with all of the following:

1. Unchanged
2. Unchanged
3. Unchanged
4. The leading edge shall be visibly set apart and provided with a horizontal solid or broken stripe at least 1 inch wide on the top surface along the front leading edge of each step. This stripe shall be plainly visible to persons on the pool deck. The stripe shall be a contrasting color to the background on which it is applied, and the color shall be permanent in nature and shall be a slip-resistant surface.

411.5.2 Underwater seats and benches. Underwater seats and benches, whether used alone or in conjunction with pool stairs, shall comply with all of the following:

1. Unchanged
2. Unchanged
3. Unchanged
4. Unchanged
5. The leading edge shall be visually set apart and provided with a horizontal solid or broken stripe at least 1 inch wide on the top surface along the front leading edge of each step. This stripe shall be plainly visible to persons on the pool deck. The stripe shall be a contrasting color to the background on which it is applied, and the color shall be permanent in nature and shall be a slip-resistant surface.
6. Unchanged
7. Unchanged

Section 610.5.1; Change to read:

610.5.1 Uniform height of 9-10 inches. Except for the bottom riser, risers at the centerline shall have a maximum uniform height of 9-10 inches (229-254 mm). The bottom riser height shall be permitted to vary from the other risers.

Section 804 Diving Water Envelopes; Change to read as follows:

Section 804.1 General. The minimum diving water envelopes shall be in accordance with Table 804.1 and Figure 804.1, or the manufacturer's specifications, whichever is greater. Negative construction tolerances shall not be applied to the dimensions of the minimum diving water envelopes given in Table 804.1.

Sec. 4-180. - Specific Amendments to the 2021 International Property Maintenance Code (IPMC).

The IPMC Code, 2021 Edition, is amended as follows:

- 1) Section 101.1 is amended to read as follows:
 101.1 Title. These regulations shall be known as the International Property Maintenance Code of the City of Keller, hereinafter referred to as "this code."
- 2) Section 103.1. Creation of agency. The **Code Compliance Department** is created and the official in charge thereof shall be known as the code official. [Remainder of text unchanged].
- 3) Section 110.04. Failure to comply. Any person who shall continue any work after having been served with a Stop Work Order, except such work as that person is directed to perform to remove a violation or unsafe condition, shall be subject to a fine ~~established by the authority having jurisdiction.~~ **Such person shall be fined not more than the maximum allowed as provided in Section 2-10 of the Unified Development Code per violation for public health and sanitation provisions. Each day each violation exists constitutes a separate offense and shall be punishable as such. In such case of willful or continued violation by any company, person,**

agent, employee, or company officer, the City shall have the power to revoke and repeal any license under which the company, person, agent, employee, or company officer may be acting, and revoke all permits, privileges and franchises granted such person or entity.

- 4) Section 303.2. Enclosures. Private swimming pools, hot tubs and spas, containing water more than 24 inches (610 mm) in depth shall be completely surrounded by a fence or barrier not less than 48 inches (1219 mm) in height above the finished ground level measured on the side of the barrier away from the pool. Gates and doors in such barriers shall be self-closing, self-latching. Where the self-latching device is less than 54 inches (1372 mm) above the bottom of the gate, the release mechanism shall be located on the pool side of the gate. Self-closing, self-latching gates shall be maintained such that the gate will positively close and latch when released from an open position of 6 inches (152 mm) from the gatepost. An existing pool enclosure shall not be removed, replaced or changed in a manner that reduces its effectiveness as a safety barrier.
- 5) Section 302.3. Sidewalks and Driveways. **Private** sidewalks, **private** walkways, **private** stairs, **private** driveways, **private** parking spaces and similar areas shall be kept in a proper state of repair, and maintained free from hazardous conditions. **Such spaces shall also be maintained free of vegetation and shall be trimmed and edged between the public sidewalk and the curb or pavement, and between any fence, wall or barrier and the curb or pavement.**
- 6) Section 302.4. Weeds. Premises and exterior property shall be maintained free from weeds or plant growth in excess of **twelve inches (12")**. Noxious weeds shall be prohibited. Weeds shall be defined as all grasses, annual plants and vegetation, other than trees or shrubs provided; however, this term shall not include cultivated flowers and gardens.

Upon failure of the *owner* or agent having charge of a property to cut and destroy weeds after service of a notice of violation, they shall be subject to prosecution in accordance with **Section 109.3** and as prescribed by the authority having jurisdiction. [Remainder of text unchanged].

- 7) Section 304.3. Premises Identification. Buildings shall have approved address numbers placed in a position to be plainly legible and visible from the street or road fronting the property, **and from any alley used for vehicular access**. [Remainder of text unchanged].
- 8) Section 304.14. Insect Screens. ~~During the period from [DATE] to [DATE], e~~Every door, window, and other outside opening required for *ventilation* of habitable rooms, food preparation areas, food service areas or any areas where products to be included or utilized in food for human consumption are processed, manufactured, packaged, or stored shall be supplied with *approved* tightly fitting screens of minimum 16 mesh per inch (16 mesh per 25 mm), and every screen door used for insect control shall have a self-closing, device in good working condition.

Exception: Screens shall not be required where other *approved* means, such as air curtains or insect repellent fans, are employed.

- 9) **305.1.1. Unsafe Conditions.** The following conditions shall be determined as unsafe and shall be repaired or replaced to comply with the International Building Code, International Existing Building Code, or **International Residential Code** as required for existing buildings: [Remainder of text unchanged].

- 10) **306.1.1. Unsafe Conditions.** Where any of the following conditions cause the component or system shall be determined as unsafe and shall be repaired or replaced to comply with the International Building Code, International Existing Building Code, or **International Residential Code**: [Remainder of text unchanged].
- 11) **602.3 Heat Supply.** Every *owner* and *operator* of any building who rents, leases or lets one or more *dwelling units* or *sleeping units* on terms, either expressed or implied, to furnish heat to the *occupants* thereof shall supply heat ~~during the period of [DATE] to [DATE]~~ to maintain a minimum temperature of 68 degrees F (20C) in all habitable rooms, *bathrooms* and *toilet rooms*. [Remainder of text unchanged].

Exceptions:

- ~~1. When the outdoor temperature is below the winter outdoor design temperature for the locality, maintenance of the minimum room temperature shall not be required provided that the heating system is operating at its full design capacity. The winter outdoor design temperature for the locality shall be as indicated in Appendix D of the *International Plumbing Code*.~~
- ~~2. In areas where the average monthly temperature is above 30 degrees F or (-1 C), a minimum temperature of 65 degrees F (18 degrees C) shall be maintained.~~

- 12) **602.4. Occupiable Work Spaces.** Indoor occupiable work spaces shall be supplied with heat ~~during the period of [DATE] to [DATE]~~ to maintain a minimum temperature of 65 degrees F (18C) during the period the spaces are occupied. [Remainder of text unchanged].

Exceptions:

- ~~1. Processing, storage and operation areas that require cooling or special temperature conditions.~~
- ~~2. Areas in which persons are primarily engaged in vigorous physical activities.~~