

Section 8.17 TC - Town Center

1. *General Purpose and Description.*

- a. The Town Center district is intended to serve as a mixed use community retail center. Mutually supportive office, civic, cultural, entertainment, and residential uses are planned to enhance the viability of this mixed use community retail center. Multiple, complementary uses may be mixed vertically within the same building and/or may be mixed horizontally in multiple buildings. The form of development is compact with tightly grouped buildings arranged around a connected street and sidewalk network that serves vehicle, pedestrian, and bicycle transportation. Building architecture reflects a distinct look and identity. Open space, street trees, street lighting, benches, and other amenities create a human scale environment. The standards of this district are unique to the Town Center district.
- b. The Master Plan for Town Center is a conceptual layout of buildings, streets, buffers, landscaping, and open space within the Town Center district (see Figure 1 within this section.) Building locations, sizes, orientations, and other features as shown on the Master Plan are intended to be illustrative rather than a mandatory development plan. The exact location and precise boundaries for various developments are established by the standards of this district and identified through the site plan review process required as part of this district.
- c. All requirements of this Code are applicable to Town Center district unless otherwise specifically noted in this section.

2. *Permitted Uses in Town Center.*

- a. The following use charts specify those uses permitted in the Town Center district.
- b. Uses in Town Center district shall be generally pedestrian oriented and encourage pedestrian traffic. Uses with drive-through lanes are discouraged in Town Center, are permitted only by Specific Use Permit. If such uses are allowed by City Council approval, the use must be mitigated with special design features during site plan review.

TC Zoning District Use Table

P = Permitted Uses

SUP = May Be Approved As Specific Use Permit

- = Not Permitted

Use	SUP or P
Administrative, professional or corporate office	P
Automobile electric charging station	SUP
Bakery (retail)	P
Bank, saving, loan, and credit unions, including automated teller	SUP
Barber shop or beauty salon within multi-use retail	P
Batching plant (temporary)	Permit
Brewery with retail sales on and off premise	SUP
Brewery with entertainment inside or outside	SUP
Child Care (Center) as an accessory use only	SUP
Copy shop or printing shop	P
Dance studio or aerobics center	P
Distillery with 1,500 square-foot tasting room	SUP

Created: 2023-08-14 15:49:40 [EST]

(Supp. No. 34)

Dry cleaning (small shop) in a multi-use building	P
Dry cleaning free-standing building	SUP
Entertainment Facility (Indoor)	SUP
Fitness Center/Health Club	P
Fuel Pumps/Sales*	SUP*
Grocery store or food market	SUP
Gunsmith (repair only)	SUP
Hotel	SUP
Kennels, Grooming Only	P
Kennels (Indoor Pens Only)	SUP
Liquor Store (10,000 sf or greater)	SUP
Minor medical emergency clinic	SUP
Mixed-Use Residential	SUP
Museum or art gallery	P
Offices, City, County, State, and Other Governmental	SUP
Optical store, optician or optometrist	P
Pharmacist or drug store	SUP
Private club	SUP
Private park	P
Public parking garage (associated with building)	P
Religious institution	P
Residential Single Family Dwelling: Townhome/Patio Home	PD
Restaurant, café, cafeteria	P
Restaurant with Drive-thru/Drive-in	SUP
Retail uses and services wholly enclosed within a building	P
Seasonal Sales	SUP
Spa to include Cosmetologists (Hair, Nails, Face) & Massage Therapists Licensed in TX	SUP
Studio, art or photographic (within multi-use retail)	P
Studio, art or photography (stand-alone)	P
Temporary field construction office	P
Utility structures (Private or Franchised)	SUP
Utility structures (public)	P
Veterinarian Clinic	P
Winery with retail sales (either on or off premise)	SUP
* See supplemental regulations for Fuel Pumps/Sales in this district (below)	

3. *Design Review Required for Town Center.* All development within the Town Center district shall be subject to design review as part of the site plan review process. A site plan as outlined in this Code shall be submitted for each use in Town Center. The Development Review Committee may also require any other reasonable and pertinent information necessary for design review. Design review is required in this district to ensure that development within the district is in conformance with design guidelines for the Town Center and that:
- a. The proposed development is architecturally compatible with other development in the surrounding areas.

-
- b. The proposed development is within the character of the Town Center concept as a community focal point with quality development having a pedestrian orientation, suitable amenities, and an overall design theme.

4. *Design Standards for Town Center.*

- a. *Street Network, Building Siting and Massing.* The layout of public streets and private drives, and building location, design, and orientation, should generally conform to the approved Master Plan. The following standards shall be used to evaluate the conformance of site development to the intent of the Master Plan:

- 1) Town Center Lane shall be extended north of Keller Parkway and shall terminate in a circle, loop, or some other monumental configuration and design similar to the southern terminus of Town Center Lane at Bear Creek Parkway. A public street or private drive aisle shall connect the northern terminus of Town Center Lane to Rufe Snow Drive.
- 2) Public streets, private drives, and sidewalks shall be designed to form an interconnected street system that serves pedestrians and cyclists as well as vehicular transportation.
- 3) Site layout shall reinforce street edges and create pedestrian scaled open spaces.
- 4) Buildings shall be sited perpendicular and parallel to streets.
- 5) Building fronts and entries shall be articulated and be oriented toward streets, and shall be arranged to create courtyards and other human scale spaces.
- 6) Where possible, buildings shall be arranged to provide views and access to open spaces.
- 7) Off-street surface parking should be located behind or to the sides of buildings where possible. Large parking lots in front of buildings, along the street frontage, are prohibited. Buildings fronting streets are allowed to have only two rows of parking and one driving lane.

- b. *Building Height, Building Area, and Setback Requirements.*

- 1) Unless otherwise stated, the building height in the Town Center district shall be two (2) stories, not to exceed thirty-five (35) feet. Restaurant uses, kiosks and fuel pump canopies may be single-story in height by right. Hotel uses in the Town Center South sub-district only may be five (5) stories in height by right. Single-story building heights and three (3) to five (5) story building heights may be approved by Specific Use Permit. Maximum height shall be five (5) stories or sixty feet (60'). If a single story building is proposed the building façade shall either be a minimum height of twenty feet (20') or shall reflect a two-story design to provide for compatibility with other buildings in the area. Single-Family Attached Dwelling (Townhouse) and Patio Home uses shall meet the maximum heights as per the Design Standards within this section.
- 2) Building footprints and locations should generally follow the arrangement of the Master Plan. No building footprint in Town Center shall be less than six thousand (6,000) square feet of air-conditioned space. Building footprints less than six thousand (6,000) square feet may be approved by Specific Use Permit.
- 3) Restaurants in Town Center may be one story and incorporate their own special design features in keeping with the design guidelines and spirit of Town Center.
- 4) The setbacks for non-single family residential uses in the Town Center district shall be determined based on the building and site design at the time of site plan review provided that all building and fire code requirements are met at the time of construction and proposed setbacks compliment the surrounding area .

-
- 5) In Town Center, the minimum setback from an adjacent single-family residential district shall be sixty feet (60'). For structures over thirty-five feet (35'), the minimum sixty-foot (60') setback shall be increased one foot (1') for each additional two feet (2') in building height above thirty-five feet.
 - 6) Mixed-use Residential uses shall comply with the building height, building area, and setback requirements as non-residential uses.
 - 7) Supplemental Regulations for Fuel Pumps/Sales.
 - a) Fuel pumps/sales shall only be allowed as an accessory use with a grocery or food store, fifty thousand (50,000) square-feet or larger in size, and may be approved by Specific Use Permit (SUP).
 - b) Convenience stores shall not be allowed as part of the fuel pumps. Kiosks may be used in lieu of convenience stores and shall not exceed 350 square feet in building area. Kiosks larger than three hundred fifty (350) square feet may be considered as part of the site plan variance process. Kiosks shall not be required to meet the minimum building footprint of Town Center.
 - c) The design elements of the kiosk and fuel pumps columns and canopy shall be aesthetically compatible with its associated grocery or food store and the Town Center surroundings. Fuel pump canopies shall not exceed twenty-five feet (25') in height. Fuel pump canopies and kiosks shall comply with the Town Center zoning district's building material requirements (see Section 8.17 (4.d)).
 - d) The use of lighted stripes, exposed neon tubular lights or similar material on kiosks or fuel pump canopies shall not be permitted.
 - e) Fuel pumps/sales shall not exceed four (4) fueling dispensers or eight (8) fueling pumps.
 - f) All fuel pump station amenities such as lighting fixtures, trash receptacles, and other features shall be coordinated in design with the building and fuel pump canopy and compatible with the Town Center surroundings.
 - g) The outside placement of vending machines, ice machines, merchandise, and other outside storage or displays are prohibited.
 - h) Fuel pump station canopies are allowed no more than two (2) attached signs or two (2) logos not to exceed twenty-four inches (24") in height. Kiosks shall be limited to one (1) attached sign, not to exceed twenty (20) square feet in total area and thirty-six inches (36") in height.
 - i) Fuel pump stations in Town Center may utilize electronic signage for advertisement of gas prices only. The placement of electronic signage shall be limited to monument signs. Electronic signage shall be static.
 - 8) Single-family residential uses may be allowed through PD.
- c. *Architectural Character.*
- 1) The architectural styles of buildings in the Town Center District shall be compatible with the buildings constructed within the district. Compatibility can be achieved through coordinated and complementary attributes such as building materials, colors, building forms, architectural detailing and amenities. This provision does not require that all developments be the same and diversity is encouraged in Town Center.
 - 2) All buildings shall have horizontal and vertical facade articulations.

-
- 3) Buildings with facades longer than fifty feet (50') shall have their facades broken up into smaller areas through the use of varying façade setbacks, arcades, awnings, canopies, architectural features such as plazas, columns, or other means.
 - 4) Non-single family residential buildings shall have an expression of a masonry pier or column effect at least twenty-five feet (25') on center. On the ground floor, the facade in between piers or columns shall have as much storefront glass as possible so as to enliven the facade and open it up to pedestrian involvement. Windows shall not be located higher than three feet (3') from the ground. For large uses with expansive facade areas without windows, an expression of windows with elements such as display windows or opaque windows with canopies and awnings shall be considered.
 - 5) Rooflines shall be interrupted with gables or other architectural elements to break up the building profile.
 - 6) Windows along streets shall be equally spaced with a specific rhythm and not create long areas of flat, solid spaces along streets. Varying window size and height based on the interior functions is discouraged. Windows shall be designed to reinforce a vertical appearance, not a horizontal appearance.
 - 7) If a building sides or backs to a street, public open space, or adjacent developments, the side or rear facade shall be treated in the same architectural style and material as the front facade. This includes but is not limited to the same roof treatment, building material, and window treatment. All buildings shall carry the roof treatment and facade articulation around the entire building, including the rear side.
 - 8) Sloping roof forms as a complete sloping form (pitched roof) or mansard roof shall be utilized on all buildings in Town Center. Flat roofs are allowed only based on building design as approved during the site plan review by the Development Review Committee. Roof pitch shall not be less than 4:12, but if the pitch is less than 6:12 but more than 4:12, the roof must have a projecting eave of no less than two feet (2') horizontally from the vertical wall plane. Mansard roofs shall have a pitch of not less than 1:1.
 - 9) At the intersection of the facade and roof planes, there shall be a projecting cornice element of brick or cast stone. Fibrous Cement may be allowed only with approval of the City Council.
 - 10) All non-residential buildings are required to have window head and sill details, which utilize either projecting elements or materials of a contrasting color and texture, which will highlight the window treatment.

d. *Building Material Requirements.*

- 1) The wall surface for all buildings other than glass shall be of one hundred percent (100%) masonry material compatible with the Town Center district. Seventy percent (75%) of overall wall surfaces other than glass shall be of brick, stone, or cast stone. The remaining twenty-five percent (25%) may be stucco, fibrous cement, split-face block, or other masonry material. The use of any other wall surface material may be approved by the City Council at the time of site plan review. Stucco may be used on wall surfaces of a minimum ten feet (10') above grade level.
- 2) Building colors shall be compatible with one another. Building colors shall generally be variations of red or earth tones with white or off-white accents and generally compatible with the character of Town Center.
- 3) Roof material shall be standing-seam metal, stone, clay, or concrete roofing tile. Adjacent buildings shall have similar roof material to provide for compatibility among individual developments.

- 4) The use of reflective glass is prohibited in Town Center. The use of florescent paint, florescent colors, or exterior neon tubular lights shall be prohibited. The use of lighted color bands and back-lighted plastic awnings are prohibited.
 - 5) Other building material requirements of this Code shall apply to Town Center if not specifically noted otherwise.
- e. *Landscape Easements/Setbacks.* The following minimum landscape easement/setback (measured from R.O.W.) shall be required and shown on the final plat:

FM 1709/Keller Parkway	
South Side	40 feet
North Side	30 feet
Rufe Snow Drive	
South of Keller Parkway/FM 1709	30 feet
North of Keller Parkway/FM 1709	30 feet
Bear Creek Parkway	
Building	15 feet
Parking/driving Lane	30 feet
Country Brook Lane	15 feet
Keller Smithfield Road	
South of Keller Parkway (Commercial)	50 feet
South of Keller Parkway (Residential)	20 feet
North of Keller Parkway	30 feet
Town Center Lane	11 to 17 feet based on design

- f. *Landscaping Requirements Adjacent to Rights-of-Way and Within Landscaping/Sidewalk Easements.* The streetscape within Town Center District is one of the key components that establishes a basic framework for development and establish connections among different uses. Proposed improvements are located in either the right-of-way (R.O.W.) or landscape easements on either side of the road. Easements are measured from the edge of right of way. Location of trees and shrubs further than five feet from utility lines shall remain and/or comply with UDC landscaping requirements.
- 1) FM 1709/Keller Parkway shall have a single row of matched Texas Red Oaks, minimum four-inch (4") caliper, thirty feet (30') on center, planted within the landscaping easement on each side, in accordance with specifications provided by the City (see Figure 5 within this section). A single row of tree form Yaupon Hollies shall be planted adjacent to the street in addition to the single row of Oaks. A five-foot (5') concrete sidewalk shall be constructed centered between Oaks and Hollies. Pedestrian scaled light fixtures, consistent in color and design with the City approved specifications, shall be provided at a one hundred twenty-foot (120') spacing on center.
 - 2) Rufe Snow Drive and Keller-Smithfield Road shall have a single row of Red Oaks, minimum four-inch (4") caliper, thirty feet (30') on center planted within the landscaping easement on each side in accordance with specifications provided by the City (see Figure 6 within this section). Brick columns and evergreen shrubs (required along all off-street parking areas adjacent to streets) shall not be required along Rufe Snow Drive south of tributary BB12 of Big Bear Creek. A five-foot (5') concrete sidewalk shall be constructed in a location approved by the City. Pedestrian scaled light fixtures, consistent in color and design with the City approved specifications, shall be provided at a one hundred twenty-foot (120') spacing on center.
 - 3) Country Brook Lane shall have a single row of matched Elms, minimum four-inch (4") caliper, thirty feet (30') on center planted within the right of way along both sides (see Figure 7 within

this section). A five-foot (5') concrete sidewalk shall be constructed in a location approved by the City. Pedestrian scaled light fixtures, consistent in color and design with the City approved specifications, shall be provided at a one hundred twenty-foot (120') spacing on center.

- 4) Bear Creek Parkway shall have a single row of matched Elms, minimum four-inch (4") caliper, thirty feet (30') on center planted within the right-of-way along both sides and the center medians (see Figure 8 within this section). A five-foot (5') concrete sidewalk shall be constructed in a location approved by the City. Pedestrian scaled light fixtures, consistent in color and design with the City approved specifications, shall be provided at a one hundred twenty-foot (120') spacing on center.
- 5) Town Center Lane shall have a single row of Cedar Elms, minimum four-inch (4") caliper, thirty feet (30') on center planted within the landscape easement on each side in accordance with specifications provided by the City (see Figure 9 within this section). Any future extension of Town Center Lane shall be consistent in design, landscaping, and special features with the existing Town Center Lane.

g. *Parking Lot Lay Out, Landscaping, and Lighting.*

- 1) Parking for all uses shall be provided in accordance with this Code, however, smaller parking ratios may be considered at the time of site plan approval. The sharing of parking for two (2) or more uses is encouraged and may be utilized. The minimum number of parking spaces shall be determined by a study following the procedures of the Urban Land Institute or Institute of Transportation Engineers parking guidelines.
- 2) All parking lots and drives shall be constructed of reinforced concrete. Concrete pavers, consistent with the Town Center specifications, shall be utilized at select locations such as building entry or parking lot islands.
- 3) Concrete curbs shall be provided at the edge of all surface parking areas and around all islands.
- 4) Twenty-five (25) square feet of landscaped area shall be provided for each surface parking space and one (1) tree shall be provided for every twelve (12) surface parking spaces. A maximum of twelve (12) surface parking spaces is permitted between trees. Large, shade providing canopy trees with a minimum three-inch (3") caliper, shall be used to meet this requirement. Required trees shall be in accordance with the list of Large Trees, provided in Section 10.02.
- 5) Parking lot trees shall be planted in islands a minimum of ten feet (10') wide or in curbed five feet-by-five feet (5'X5') diamond cut-outs in pavement. Islands or diamond cut-outs shall be placed to offer shaded parking from the western sun whenever practicable. Additional landscaping in these islands or diamond cut-outs shall be heat tolerant and low maintenance varieties accordance with the list of Large Trees, provided in Section 10.02.
- 6) If the proposed number of surface parking spaces for a development exceed the Code requirement by ten percent (10%), fifty (50) square feet of landscaping per each additional parking space shall be provided.
- 7) All off-street parking areas adjacent to streets shall be screened by a solid row of evergreen shrubs, to create a three-foot (3') evergreen hedge, and brick column with stone caps, thirty feet (30') on center, in accordance with specifications provided by the City (See Figures 18 and 19 within this Section)
- 8) A minimum five-foot (5') foundation planting shall be provided along the front and sides of all buildings and parking structures. Potted plantings may be considered around patio dining areas in lieu of foundation plantings adjacent to the patio area. Foundation planting and landscape

islands with trees may also be required at the rear of the building if visible from streets, other buildings, or open spaces within Town Center.

- 9) In the Town Center district, landscaping shall comply with the Landscaping section of this Code except that the required canopy trees for side and rear lot buffers shall be in accordance with the list of Large Trees, provided at the end of this article. For the Town Center district, the following landscape plant materials are required in side and rear buffers that abut single-family residential zoning districts:
 - a) Five (5) gallon dwarf Yaupon Holly evergreen shrubs shall be planted at five feet (5') on-center spacing adjacent to the required screening wall.
 - 10) Required screening walls shall comply with Section 9.09 of this Code except as noted below. In Town Center, required screening walls must comply with all of the following:
 - a) Screening walls shall be a minimum of eight feet (8') in height.
 - b) Screening walls shall be made of pre-cast concrete with panels and columns. Panels shall be monolithic - no more than one panel between posts - with a running bond, brick pattern stamped or cast into the panel on both sides of the panel. The material and color of the panel shall be complimentary and compatible to existing screening walls.
 - 11) All landscaping and parking lot islands shall be irrigated in accordance with an approved automatic drip irrigation system. Landscaping shall be maintained in good condition.
 - 12) Landscape lighting may be used to highlight landscape elements, building entries, and other important architectural features and accent elements such as fountains and sculptures.
 - 13) Parking lot lighting fixtures shall be provided in accordance with the approved specifications for Town Center (see Figure 16 within this section). A lighting plan shall be required, illustrating proposed light fixtures and respective candle footprints to determine number of required fixtures for maximum safety and pleasant appearance. Ornamental light fixtures are required within the front yard/front parking lot. Large parking lots may utilize another type of fixture as approved by the City. The total height for parking lot lights shall not exceed twenty feet (20') unless approved at the time of site plan review. A maximum height of thirty inches (30") is allowed for light pedestals within parking lots.
 - 14) Building lighting shall be limited to decorative lighting. Standard wall pack lights shall not be used are in the Town Center district.
- h. *Driveway Locations and Turning Lanes.*
- 1) Parking lots and driveways shall connect to provide internal circulation for the development.
 - 2) A ten-foot (10') band of pavers, consistent in color and design with the approved specifications, shall be provided in crosswalks and entry drives. Pavers shall be antique red Uni-Décor pavers in a herringbone pattern with Holland Stone Soldier Course, as manufactured by or equal to Pavestone Co., Grapevine, Texas.
 - 3) Turning lanes shall comply with the general requirements contained in this Code.
- i. *Sidewalk Patios.*
- 1) *Sidewalk Patio.* The design of the interior and immediate surroundings of a sidewalk patio should adhere to the following guidelines.
 - a) The clear height from grade level to any obstruction such as an overhead canopy should be a minimum of seven feet (7').

-
- b) The surface area of an outdoor patio may not exceed the interior floor area of the primary licensed establishment.
 - c) The path to the door of the primary licensed establishment shall be maintained at three feet (3').
 - d) The patio shall extend to the building line when located between the primary licensed establishment and the street.
- 2) *Patio Fencing.* Fences or railings are used to delineate and contain the patio.
- a) A fence or other vertical barrier must be used to delineate the perimeter of the patio area.
 - b) The width of any opening in a fence should be no greater than six and a half feet (6.5') and no less than three feet (3').
 - c) The required height of a fence facing the street is three and a half feet (3.5'). Side screens may be up to seven feet (7') high above the grade. Such screens should not be entirely opaque but may be formed by structures with lattice or grillwork and climbing vines.
 - d) Fences and screens should be easily removable at all times.
 - e) The design, materials and colors used in the development of the patio restaurant should be of high quality finish and compatible with the streetscape.
 - f) All finishes should be clean and free of any exposed screws or other fasteners. g) Perimeter fences shall not obstruct the line of sight for pedestrians and drivers.
- 3) *Awning.* Awnings can be used to provide shade and weather protection for the patio as well as visual screening from adjacent uses.
- a) Materials should be securely fastened to a frame, which is either retractable or demountable.
 - b) Sheltering material should be fabricated and finished to fit the supporting structure with no loose or unsecured edges.
 - c) Materials and colors should coordinate with the surrounding buildings and streetscape elements. They should generally contribute to the design theme of the street.
 - d) The awning should not extend into the public sidewalk adjacent to the patio.
 - e) The awning should attach to the building below the signage identifying the restaurant with a minimum height of seven feet (7').
 - f) Lighting and other attachments to the awning should be securely fixed and integrated to the supporting structure.
 - g) A building permit is required for awnings.
 - h) Awnings shall be maintained in excellent condition at all times.
- 4) *Enclosures.* Enclosures may be used for more extensive weather protection and to extend the patio season.
- a) Enclosures must include a minimum of one continuous opening (from ground to canopy) to the outside (ie. no roll-down walls of any kind, however slide up/down doors are acceptable) that comprises at least 25% of the total perimeter of all of the patio walls.
 - b) The enclosure area should be well ventilated to provide for dispersion of smoke and exchange of air.

-
- c) Ventilation should be directly to the exterior and may be achieved by passive means through vents in the awning and/or active fans.
 - d) Cash machines should not be located within the patio area, except where enclosed within a freestanding building or kiosk.
 - e) A building permit is required for the construction of an enclosure.
- 5) *Lighting.* Lighting is important to the function and appearance of a patio as well as the safety and security of the public environment.
- a) Exterior lighting should not spill into abutting private property or interfere with the public thoroughfare.
 - b) Lighting should be demountable with no exposed cables or energized fixtures.
 - c) Lighting design should coordinate with patio furnishings and streetscape design.
 - d) Lighting should not be attached to trees or shrubs on City property; however string lighting to highlight deciduous trees within the patio area is permitted.
 - e) Lighting should be used to identify the entrance to a patio.
 - f) Pathways through a patio should be illuminated to ensure the safety of patrons and staff.
- 6) *Plant Materials.* Plant materials contribute to our general comfort and enjoyment of the patio experience.
- a) Planting of annuals, vines and container-grown vegetation is encouraged but should be easily removable from the site.
 - b) Planters should be integral with fence and deck structures to maintain a compatible design relationship.
 - c) Deciduous shade trees enhance the quality of the patio space with shade and screening.
 - d) Planting should be used along with spatial separation and structures to screen a patio from adjacent vehicle parking and circulation.
 - e) Planters must not obstruct the public right of way.
- 7) *Surface Treatment.* The paving of a patio surface provides durable and attractive platform for the patio, which is distinct from the public right-of-way.
- a) Paving should be durable, skid-proof and easily maintained in a clean and unobstructed condition.
 - b) The minimum slope of pavement should be one percent (1%) and the maximum slope four percent (4%) within the seating area.
 - c) A change in elevation may be used to define the edge of a patio, but should not create an additional barrier to movement.
- j. *Utility Placement.* All new utilities shall be placed underground. A utility plan including the location of all existing and new utility boxes shall be provided with the site plan. Utility boxes shall be located away from the rights-of-way lines and where possible at the rear of properties. All other provisions of the Private Utilities section of this Code shall be met.
- k. *Signage.* All signs or any changes, modifications, or alterations to a sign require a permit. All signs shall be externally illuminated unless noted otherwise.
- 1) *Monument Signs.*

-
- a) Each platted parcel may have one monument sign. A corner lot with more than six hundred feet (600') of frontage on two streets may have one additional sign. Residential uses may have two signs per frontage located at either side of the primary entry drive.
 - b) The design of the monument sign, including sign shape, area, height, and length, shall be in accordance with Figure 17 within this section.
 - c) Sign materials shall be as follows:
 - i. Sign Frame and Base - The exterior finish for the sign base and frame shall be brick, natural or cultured stone, cementitious stucco, or integrally- colored split face block.
 - ii. Coping and Accents - Coping and accents shall be cast stone, brick, or natural or cultured stone, or cementitious stucco. Coping and accents materials shall not be the same materials as used for the sign frame and base.
 - iii. Sign Panel/Face - The sign panel/face can be cast stone, acrylic, painted or coated aluminum, or other material commonly used for sign panel/faces. Metallic and or other highly-reflective materials and wood materials are prohibited.
 - iv. Letters/Logos - Individual letters and logos shall be pin mounted to the sign panel/face. Letters and logos may be constructed of bronze, aluminum, acrylic, or other material commonly used for sign letters and logos. If cast stone is used for the sign panel/face, letters and logos may be carved (cast) into the cast stone panel/face.
 - d) Monument signs shall be externally illuminated only.
- 2) *Attached Building Signage.*
- a) All signs shall be placed in a uniform area on each building defined by architectural detailing. Permit drawings shall show all details associated with the sign including height, location, types of material, and method of lighting.
 - b) Attached signs shall be individually mounted letters. Internally illuminated channel letters and silhouette channel lighting are allowed.
 - c) Window signs are allowed in accordance with Section 9.05 of this Code. (Amended by Ord. No. 1799 on July 5, 2016)
 - d) Temporary signs are allowed in accordance with Section 9.05 of this Code. (Amended by Ord. No. 1799 on July 5, 2016)
- 3) *Landmark Sign.*
- a) A landmark sign is a special purpose, off-premise sign that advertises multiple businesses and tenants within the Town Center Zoning District. Businesses and tenants listed on the landmark sign cannot be on the same lot as the landmark sign.
 - b) With approval of a specific use permit, one (1) landmark sign is permitted for every five-hundred feet (500') of street frontage along both sides of Keller Parkway.
 - c) Landmark signs shall be architecturally compatible to the overall architecture of the Town Center Zoning District. Decorative roof and wall design features, such as parapets, ridges, and eaves, etc. shall be incorporated into the design to provide visual interest.
 - d) Landmark signs may be two- or four-sided, and shall comply with the following standards:

-
- i. Maximum Height: Thirty-five feet (35').
 - ii. Maximum Base Dimensions: Fourteen feet (14') by fourteen feet (14').
 - iii. Maximum Sign Area Per Business/Tenant: Five feet tall (5') by ten feet (10') wide.
 - iv. The initial landmark sign shall establish the form, design, and materials for subsequent landmark signs. Subsequent landmark signs shall match the initial landmark sign.
 - 4) *Sandwich Board Sign.*
 - a) One (1) free-standing sandwich board sign (A-frame sign) shall be allowed per business.
 - b) The maximum width is twenty-four inches (24"), The maximum height is forty-eight inches (48").
 - 5) No signage or other type of advertisement is permitted on park benches and trash receptacles.
 - 6) All other signage requirements or any provisions not listed shall comply with the sign requirements (see Section 9.05 - Sign Regulations) of this Code.
 - l. *Outside Storage* - Except as provided herein, all outside storage and display is prohibited in Town Center.
 - 1) Orderly outside displays shall be approved, with a permit, only in association with special events in Town Center.
 - 2) Retailers may have limited seasonal displays for thirty (30) days, twice each year and shall obtain a permit for such uses.
 - 3) The outside placement of vending machines, ice machines, newspaper machines, grocery carts, merchandise, and other outside uses is prohibited. Temporary cart storage is allowed in the parking lot and shall be provided with six-inch (6") concrete curbs. Metal corrals are not allowed.
 - m. *Service Areas and Loading Docks.*
 - 1) All loading docks and trash collection areas shall not face a street and shall be screened in accordance with the provisions of this Code.
 - 2) Service areas, loading docks, and back doors shall not front on streets or public open spaces.
 - n. *Fences and Walls.*
 - 1) Wood fences are prohibited in Town Center.
 - 2) All fencing and walls shall be of brick, stone, or ornamental metal with evergreen landscaping or a combination thereof. The screening wall requirements in Town Center shall be in accordance with the provisions of this Code (see Section 9.08 - Fencing Requirements in Multi-Family and Non-Residential Uses).
 - o. *Pedestrian Circulation.* Each lot within the Town Center area shall provide its share of on-site pedestrian facilities. Where the concept plan shows connections to other properties, adequate provisions shall be made for creating a coordinated system of pedestrian ways throughout the district.
 - 1) Grade separations shall be provided where pedestrian ways cross thoroughfares or creeks.
 - 2) Facilities for bike parking shall be provided.
 - 3) Benches shall be provided at approximately one hundred-foot (100') intervals (See Figure 13).

- p. *Street Furnishings and Lighting.* Private development within the Town Center District shall coordinate the selection and installation of street furniture, trash receptacles, ash urns, and lighting with the standards selected by the City for the public areas in order to maintain design continuity (see Figures 12-16 within this section).
5. *Variances to Design Standards.* When special conditions exist that prevent strict compliance with the regulations in Section 4, Design Standards, the City Council, upon recommendation from the Planning and Zoning Commission, may authorize a variance or deviation from these regulations. The process for requesting a variance shall be in accordance with Article Two, Section 2.08 - Procedures for Variances from the Regulations of the Code.
6. *Illustrations.*

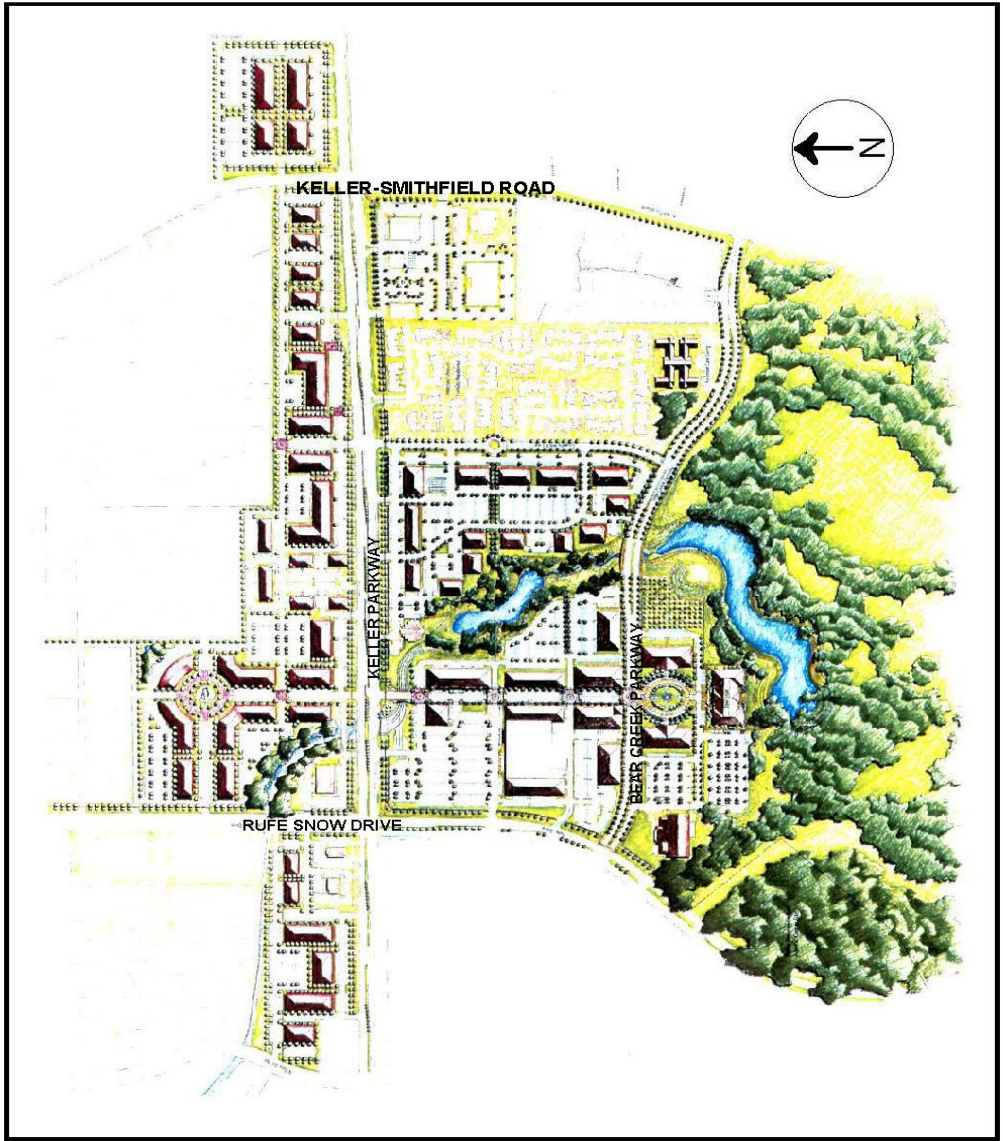

Figure 1 - Town Center Master Plan

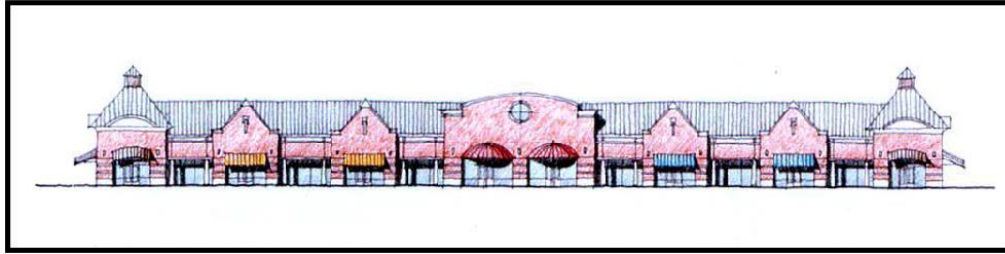

Figure 2 - Single Story Building Elevation

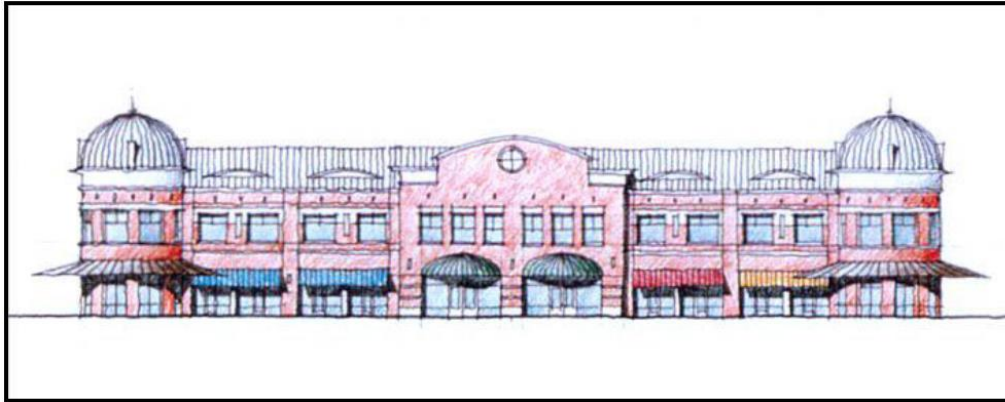

Figure 3 - Two Story Building Elevation

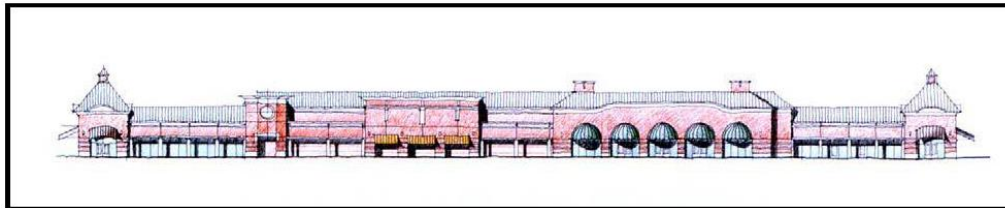

Figure 4 - Grocery/Retail Building Elevation

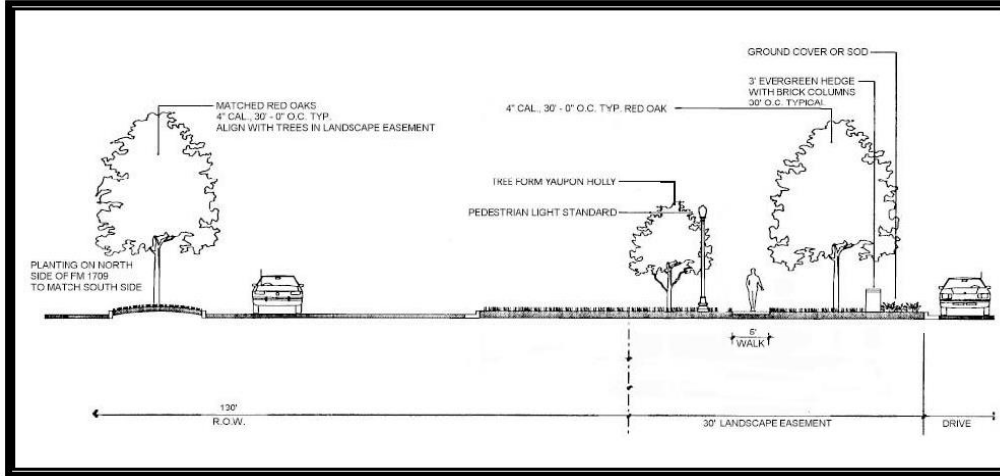

Figure 5 - FM 1709

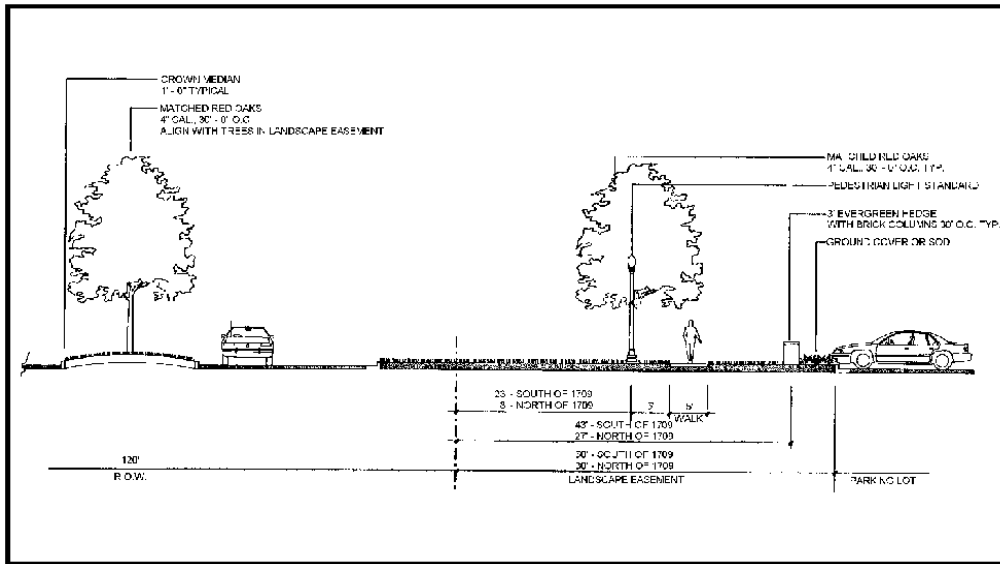

Figure 6 - Rufe Snow Drive/Keller-Smithfield Road With Retail Frontage

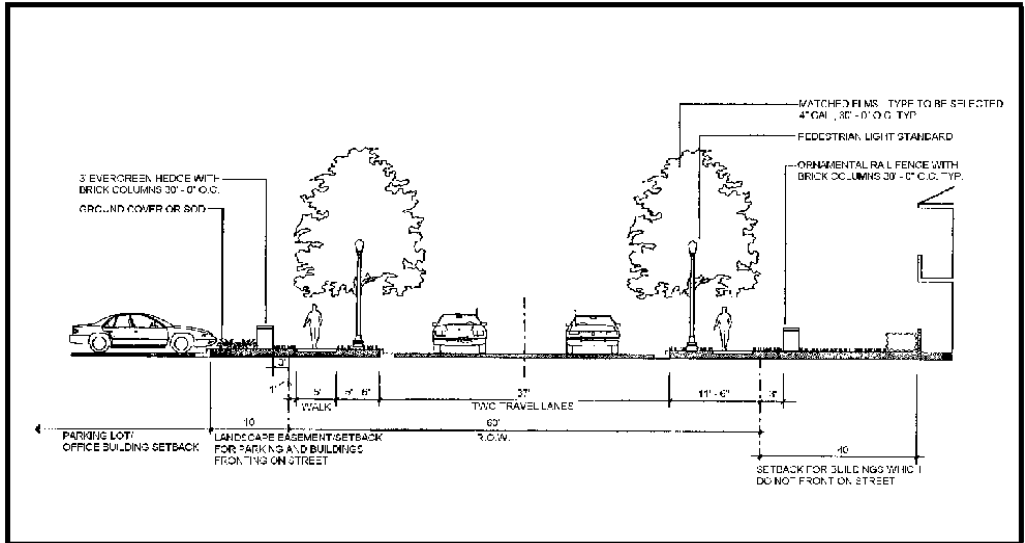

Figure 7 - Country Brook Lane

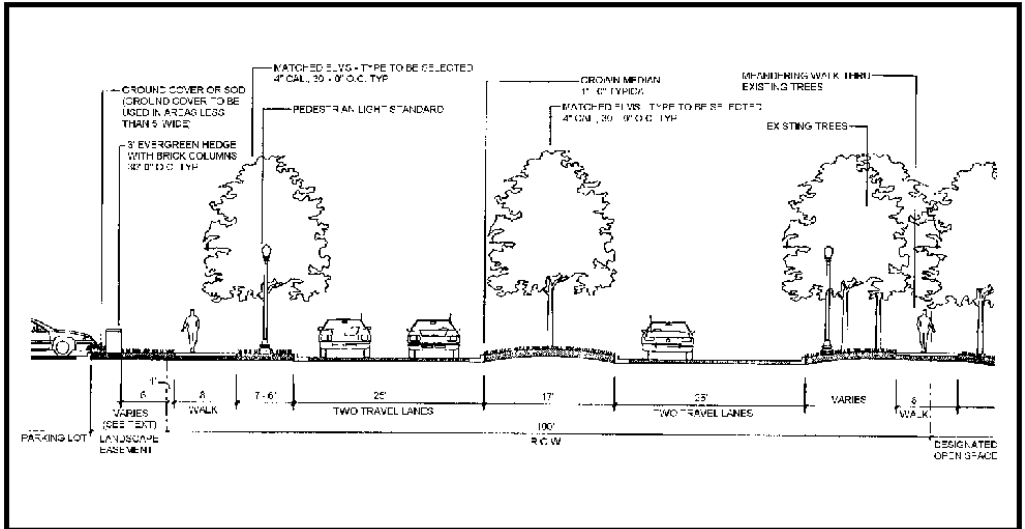

Figure 8 - Bear Creek Parkway (Divided Cross Section)

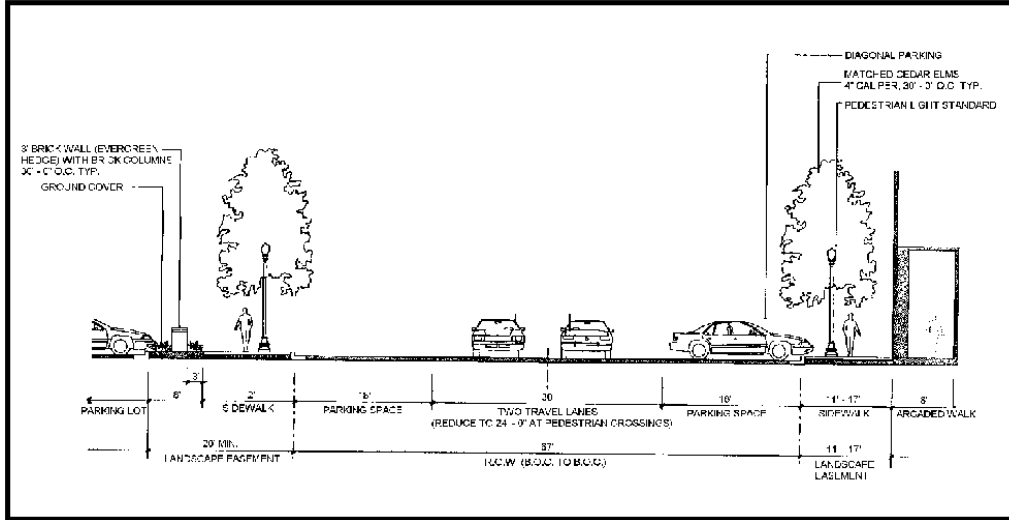

Figure 9 - Town Center Lane

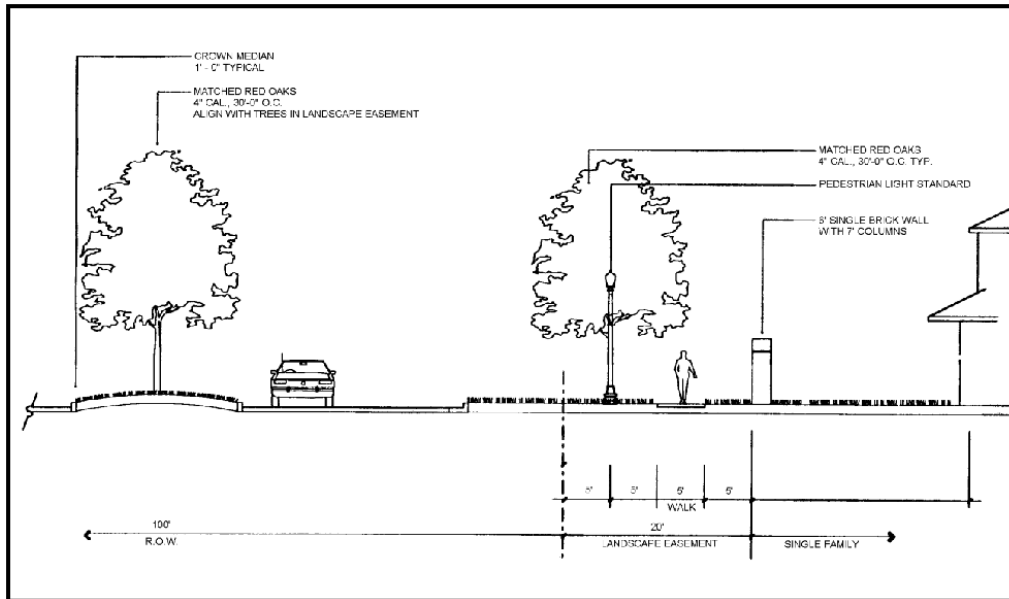

Figure 10 - Keller-Smithfield Road With Single Family Frontage

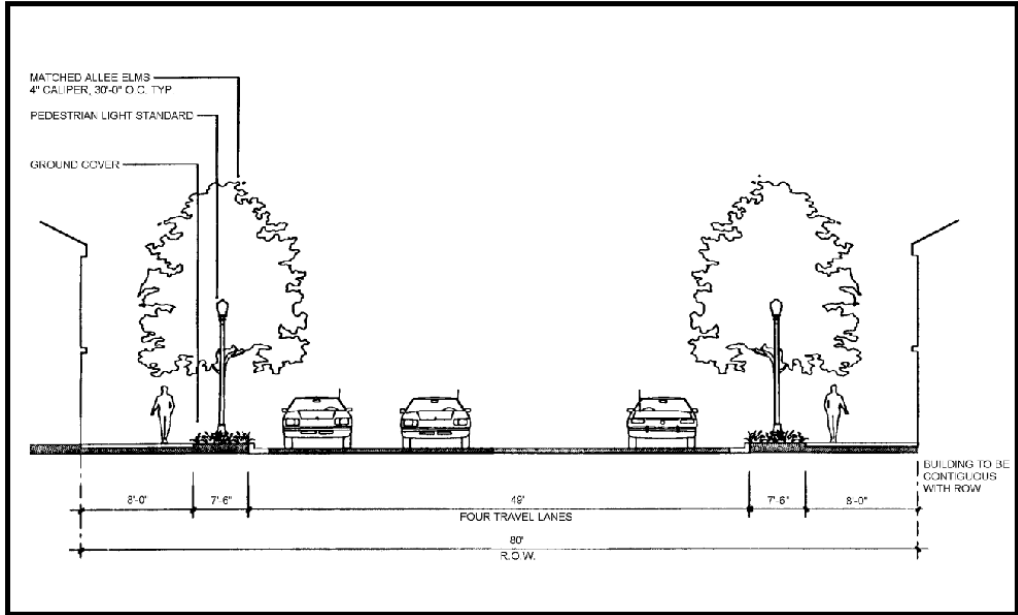

Figure 11 - Bear Creek Parkway at Town Center (Undivided Cross Section)

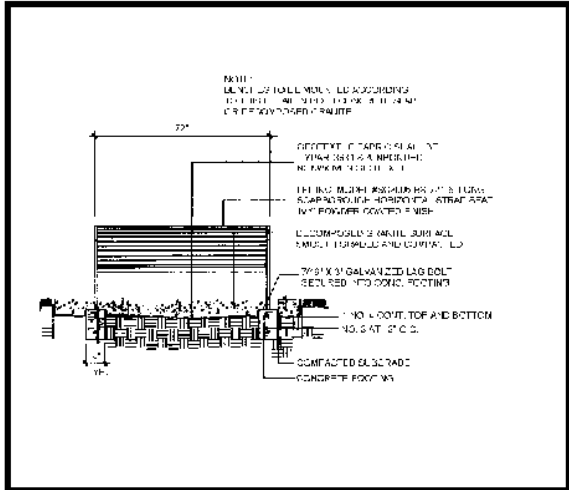

Figure 12 - Bench Details

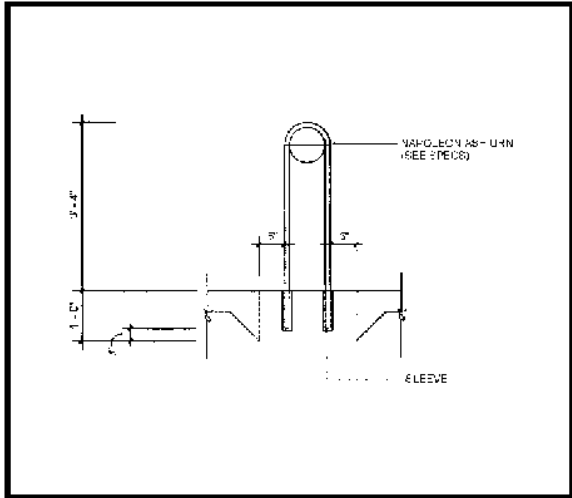

Figure 13 - Ash Urn Details

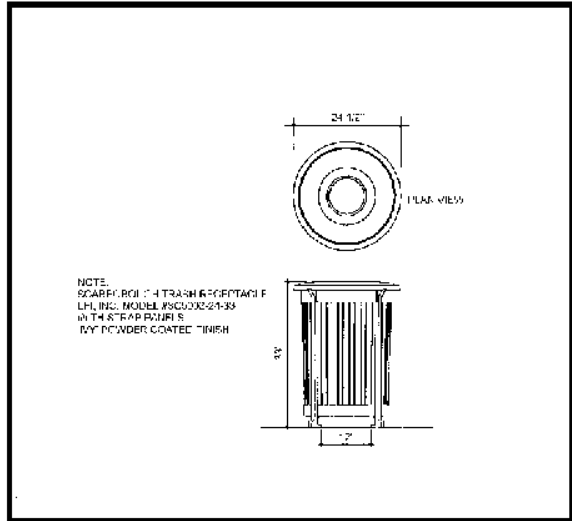

Figure 14 - Trash Receptacle Details

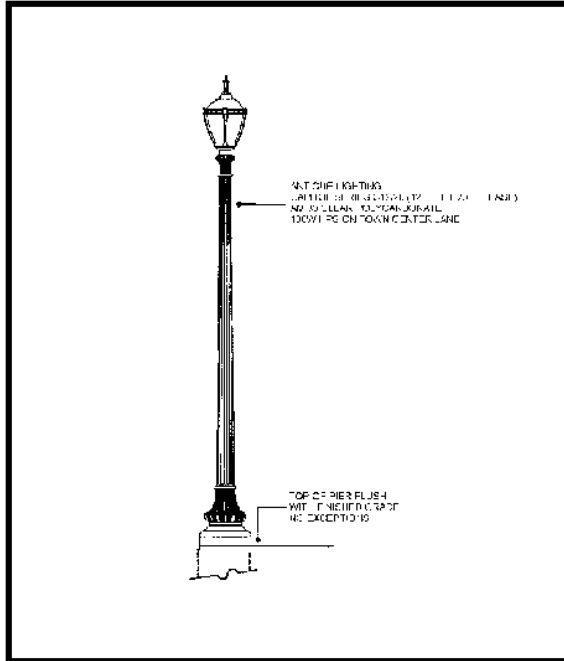

Figure 15 - Pedestrian Light Pole Details

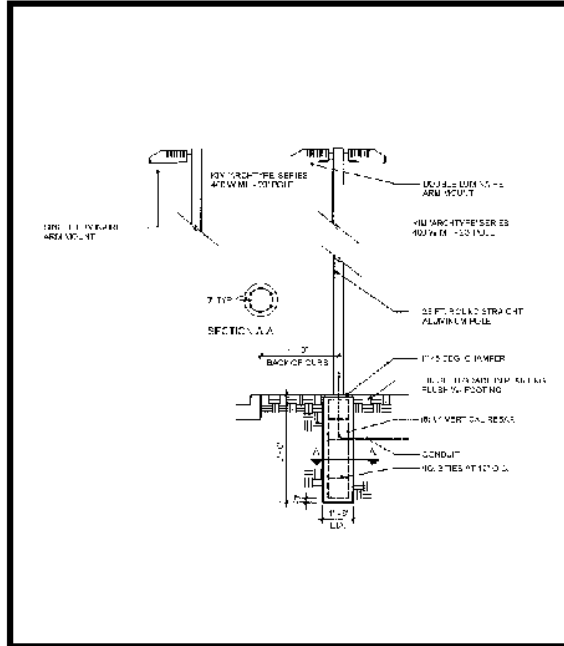

Figure 16 - Parking Light Details

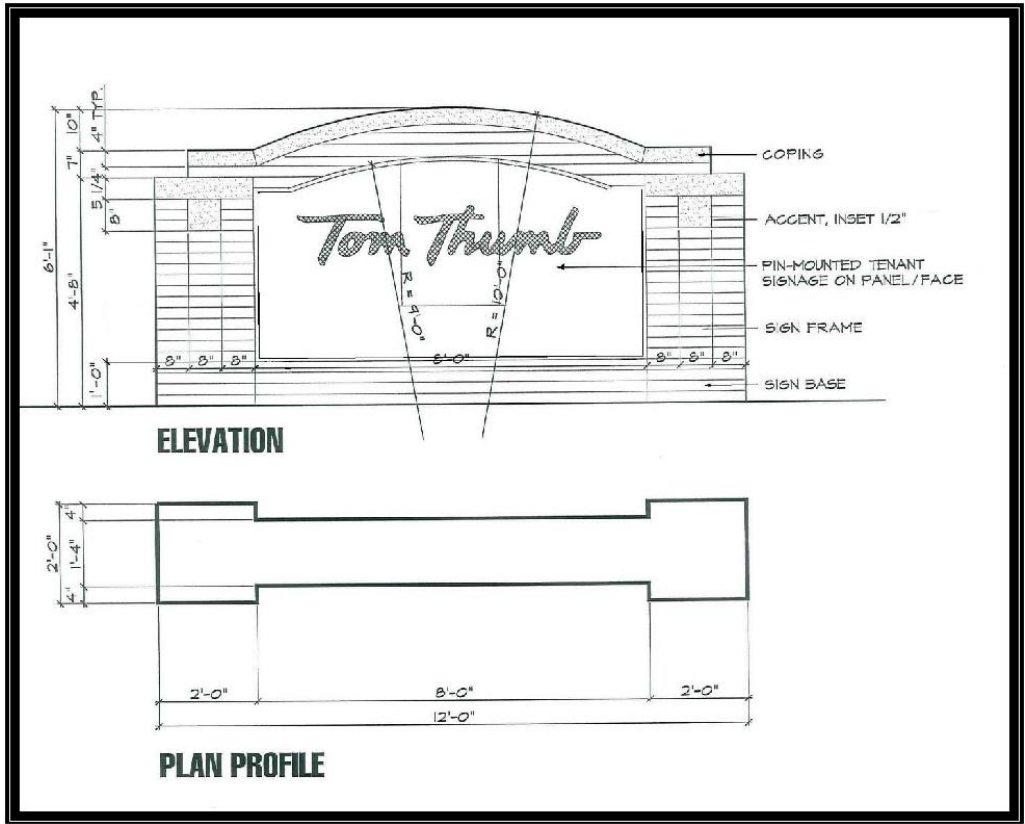

Figure 17 - Monument Sign Details

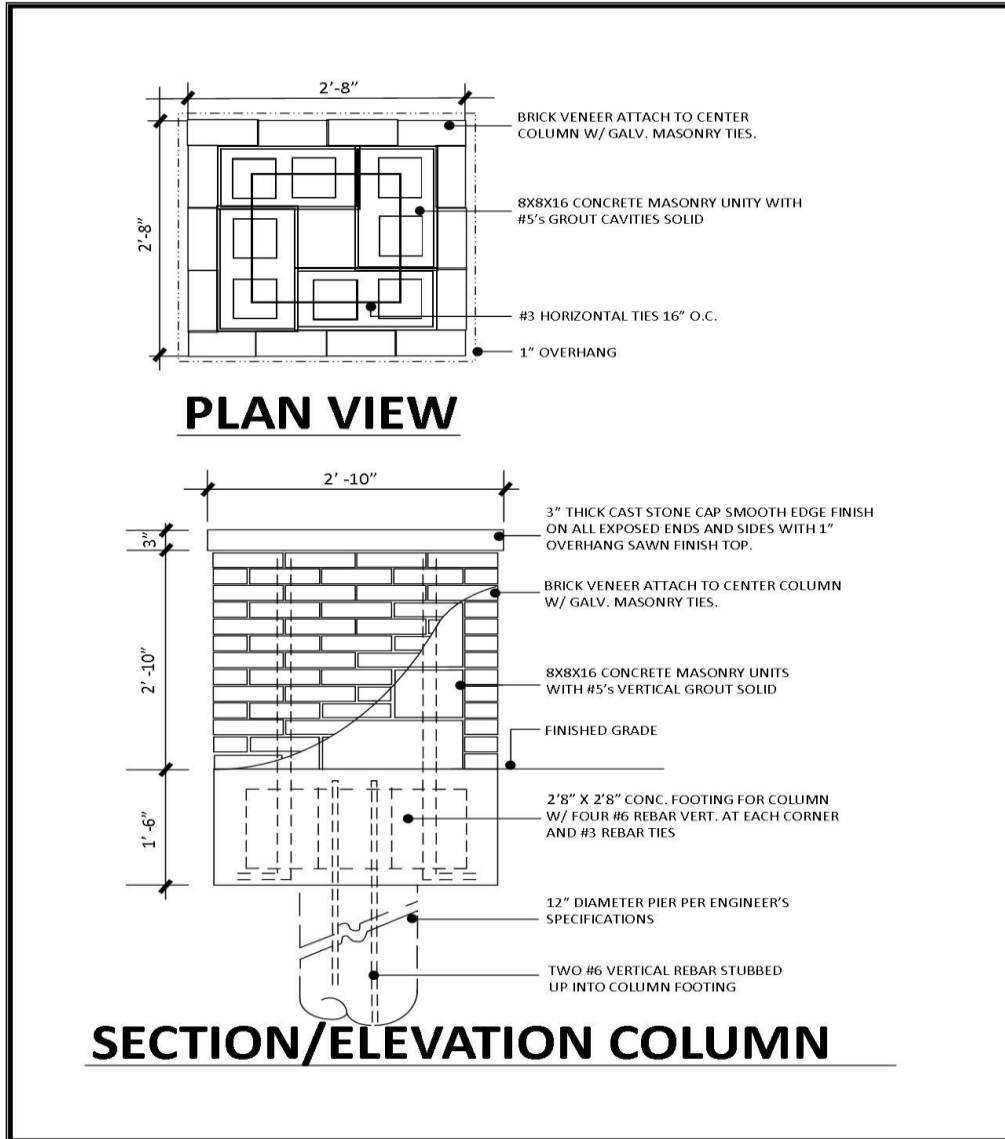

Figure 18 - Brick Columns Details

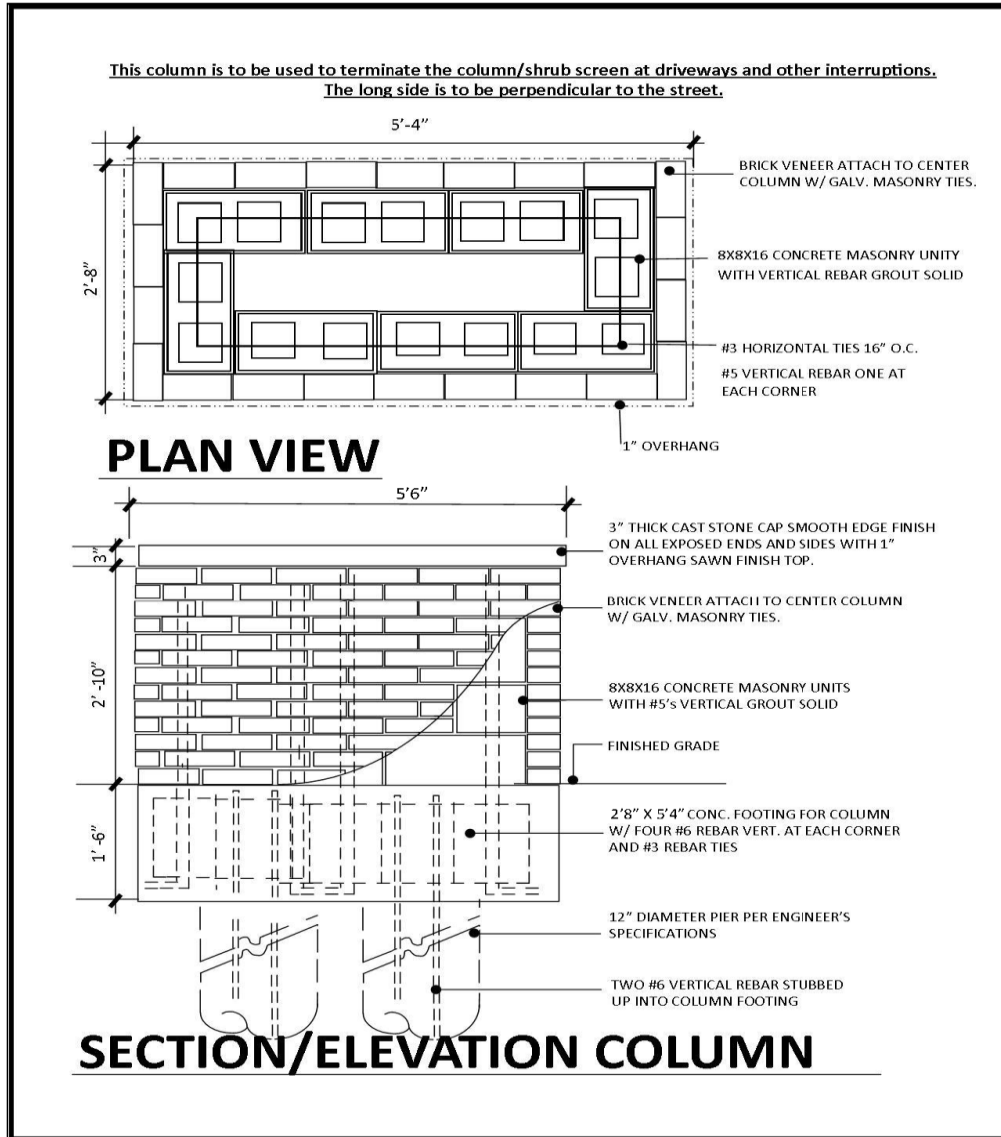

Figure 19 - Brick Columns Details

(Ord. No. 1959 , § 2(Exh.B), 12-3-19; Ord. No. 2072 , § 2(Exh. A), 6-21-22; Ord. No. 2104 , § 2, 12-6-22)

8.18. Town Center Medical Overlay

- A. *General Purpose and Description.* The purpose of the Town Center Medical Overlay District is to allow the ability for "medical clinic" uses to be utilized within this designated area by right. The regulations and standards of this overlay district reflect all standards and regulations of Town Center, except for the use of "medical clinic" uses.
1. *Boundary.* The Town Center Medical Overlay encompasses land parcels east of Town Center Lane, and north of Keller Parkway. The Town Center Medical Overlay consists of 1135, 1139, 1141, 1149, and 1151 Keller Parkway. The boundary of the District is shown in Figure 1.

- B. *Permitted Uses.* The Town Center Medical Overlay District conforms to the uses of the Town Center zoning district, with the exception that "medical clinic" uses shall be permitted by right.
- C. *General Standards.* All applicable Town Center zoning district standards shall apply.
 - 1. *Parking.*
 - a. Parking for all medical office uses shall comply with Town Center standards in Section 8.03, all other uses shall also meet Town Center standards.
 - 2. *Landscape Requirements.* All landscape requirements shall follow the Town Center landscape requirements under Section 8.03.

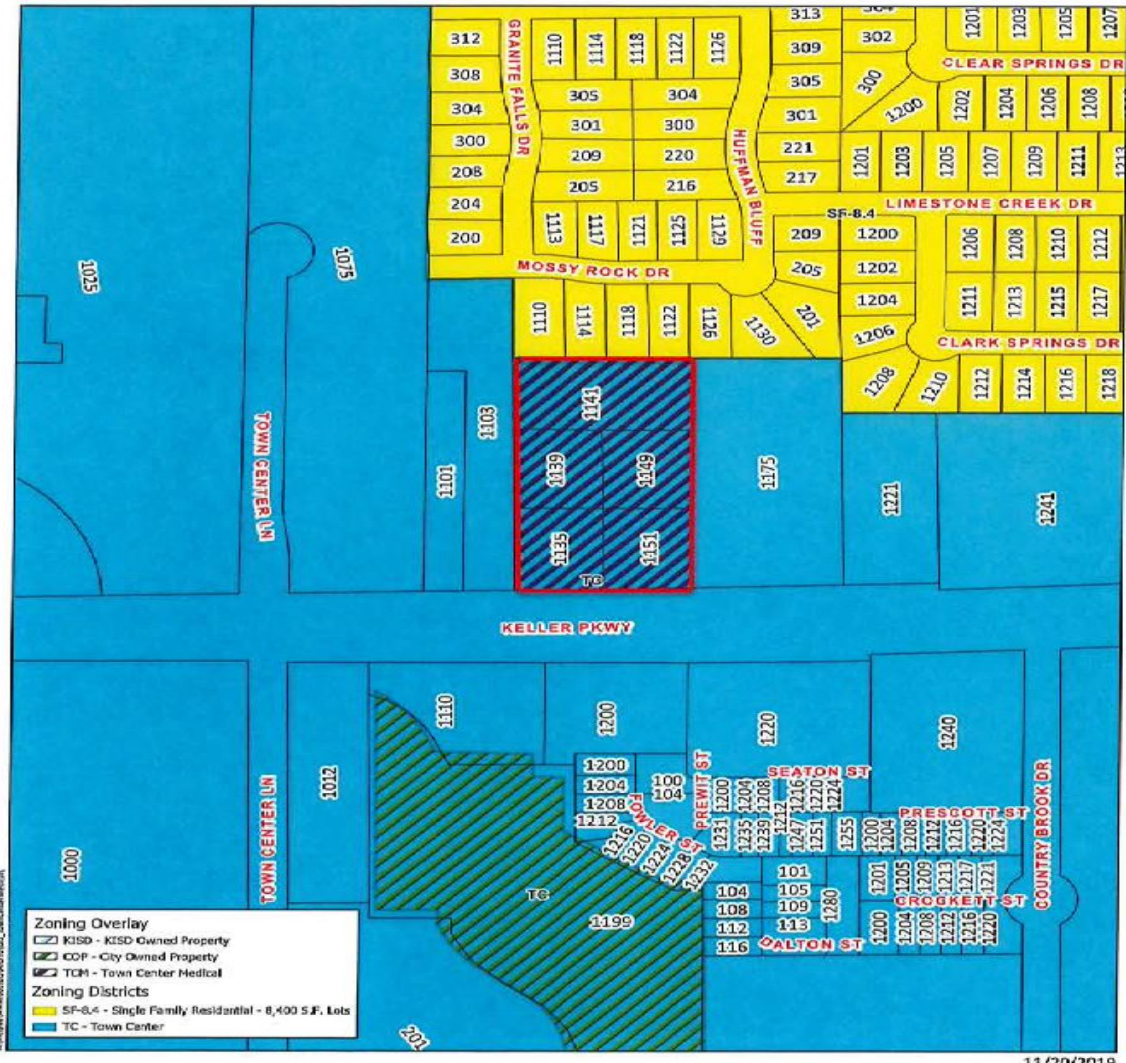

Figure 1 - Town Center Medical Overlay District

TCM Zoning District Use Table

P = Permitted Uses

SUP = May Be Approved as Special Use Permit

- = Not Permitted

Use	SUP or P
Administrative, professional or corporate office	P
Automobile electric charging station	SUP
Bakery (retail)	P
Bank, saving, loan, and credit unions, including automated teller	SUP
Barber shop or beauty salon within multi-use retail	P
Batching plant (temporary)	Permit
Brewery with retail sales on and off premise	SUP
Brewery with entertainment inside or outside	SUP
Child Care (Center) as an accessory use only	SUP
Copy shop or printing shop	P
Dance studio or aerobics center	P
Distillery with 1,500 square-foot tasting room	SUP
Dry cleaning (small shop) in a multi-use building	P
Dry cleaning free-standing building	SUP
Entertainment Facility (Indoor)	SUP
Fitness Center/Health Club	P
Fuel Pumps/Sales*	SUP*
Grocery store or food market	SUP
Gunsmith (repair only)	SUP
Hotel	SUP
Kennels, Grooming Only	P
Liquor Store (10,000 sf or greater)	SUP
Medical/Dental clinic or office	P
Minor medical emergency clinic	SUP
Mixed-Use Residential	SUP
Museum or art gallery	P
Offices, City, County, State, and Other Governmental	SUP
Optical store, optician or optometrist	P
Pharmacist or drug store	SUP
Private club	SUP
Private park	P
Public parking garage (associated with building)	P
Religious institution	P
Residential Single Family Dwelling: Townhome/Patio Home	PD
Restaurant, café, cafeteria	P
Restaurant with Drive-thru/Drive-in	SUP
Retail uses and services wholly enclosed within a building	P
Seasonal Sales	SUP
Spa to include Cosmetologists (Hair, Nails, Face) & Massage Therapists Licensed in TX	SUP
Studio, art or photographic (within multi-use retail)	P
Studio, art or photography (stand-alone)	P

Surgical Outpatient Facility	SUP
Temporary field construction office	P
Utility structures (Private or Franchised)	SUP
Utility structures (public)	P
Veterinarian Clinic	P
Winery with retail sales (either on or off premise)	SUP
* See supplemental regulations for Fuel Pumps/Sales in this district (below)	

(Ord. No. 2072 , § 2(Exh. A), 6-21-22; Ord. No. 2104 , § 2, 12-6-22)