

UST Regulations How we comply - Background

- Office of Underground Storage Tanks (OUST)
 - Determined that the Federal UST Regulations needed to be revised
 - Existing regulations dated back to 1988
 - **Industry practices have changed over years**
 - Energy Policy Act of 2005
 - Reduce UST releases



What is Kroger's process to ensure we follow proper installation for UST?

1. **Contractor certification from Tank Manufacturer.** Completes Xerxes Install Manual & Operating Guidelines Checklist
2. **Kroger Project Manager must be certified** by the Corporate Supermarket Petroleum Group – *Extensive training over several projects to ensure knowledge & leadership.*
3. **Kroger PM performs 36-point install checklist:** Pre-Install Visual, excavation requirements Anchoring, Deflection test, Backfill testing & Ballasting.
4. **Local TCEQ Region 4 representative** is invited to witness tank installation.
5. **Keller Fire Department witnesses** tank pressure test and installation of tanks.

Kroger UST Additional Equipment & Procedures

- **Additional equipment and procedures related to the design, construction, and operation of the fueling facility:**
- Entire tank and piping system is constructed with **non-corrosive materials**, **secondary containment**, and **tank monitoring** equipment. (Federal Regs)
- **Three methods of certification** that the installation has been installed, tested, and inspected in accordance with applicable state and federal regulations.
- **Daily brine monitoring** of tank interstitial space during construction.
- **Constant Electronic tank monitoring** once site opens for operation.
- Installation at a **minimum distance greater than 200 feet** from any private, public, or commercial water well (TCEQ).
- Testing of all systems in accordance with the manufacturer's installation instructions prior to placing any system in service (**Tank + Piping + Final Inspections**).

Discussion Topics for Proposed Fuel Center

- Existing Environmental Impact? – Testing in December 2022.
Environmental impact to soil & groundwater was **not detected** at the site at concentrations above the applicable regulatory screening levels.
- Light Pollution? –
Photometric plans will be included with engineering submittal for City review & approval.

Discussion Topics for Proposed Fuel Center

Noise Pollution? – Fuel traffic comparable to grocery traffic.

- a. Fuel traffic is an extension of our store.
- b. Vehicle doors open / close, engines off. Low noise fueling.

Traffic Impact? –

- a. Fuel truck traffic will enter the site per site plan truck route.
- b. Approximately 80% of Kroger fuel sales are from existing Kroger customers.
- c. Fuel will allow Keller customers to remain in Keller (plus card points).

Trucks will route this path for fuel connection
(passenger side unload)

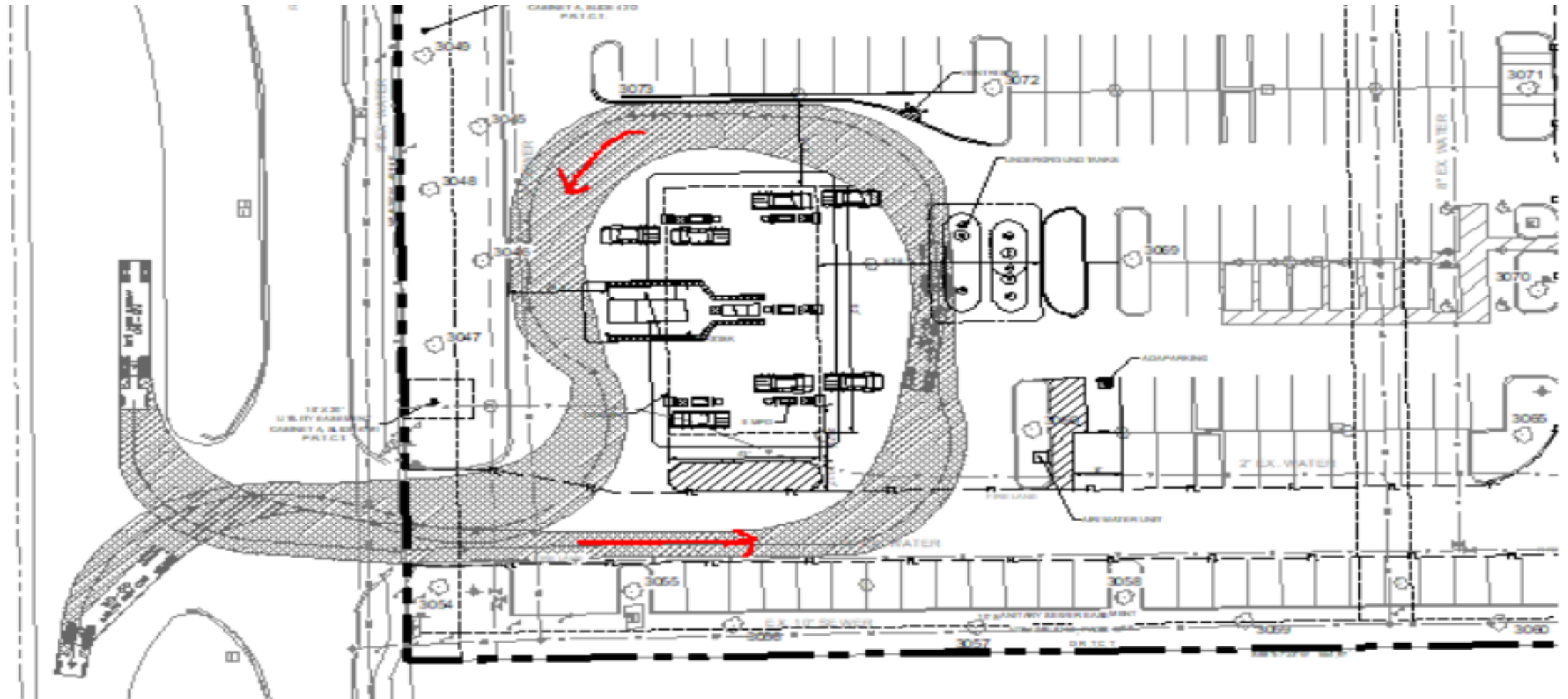

Spill Prevention

- **Tank spill prevention** equipment prevents the release of product to the environment when the fuel truck transfer hose is detached from the fill pipe.
- **Drivers required** to clean spill bucket.
- **Associate verifies** & cleans spill buckets after every truck delivery.
- **Daily associate inspections** to document any spill occurrences.
- **Associates record** any response taken to resolve.

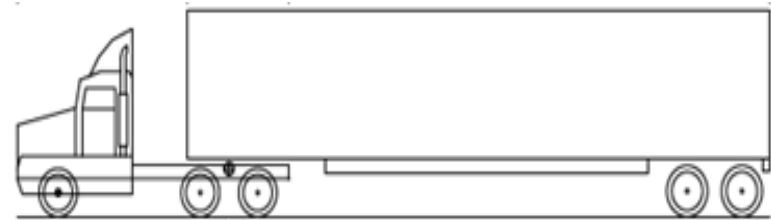
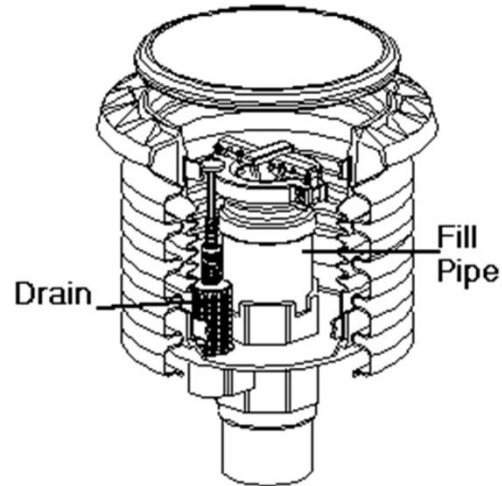
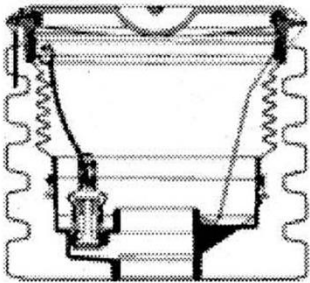
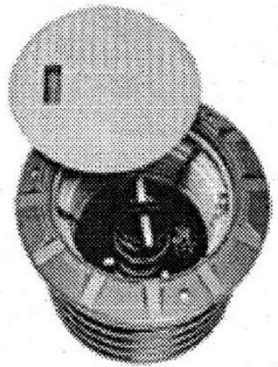

Forecourt Daily Site & Checklist

- **Associates are on the forecourt (dispenser area)** inspecting and cleaning dispensers when free from serving customers.
- **15-point dispenser cleaning checklist completed every day** – *associates address all spills immediately once known.*
- **Spill Response Kits** for small spills inside kiosk (sprays, concrete cleaners, sock booms, pads).
- **Preventive Cleaning** – associates utilize sprays & concrete cleaner as part of *weekly maintenance.*



Night Operations 10PM – 6AM

1. Kroger hours aligned with competitor station at 1000 Keller Parkway.
2. *Customer 25gallon limit.*
3. Emergency Stop for all pump located on kiosk.
4. Emergency Signs - 911 Call box for any after hours emergencies.
5. Kroger Supermarket associates available inside the store for help.

**Kroger DFW has 1 TCEQ reportable spill including night operations.
(67 stores over 20 years)**



Questions?

