

138T Symmetrical Panel

Product Data

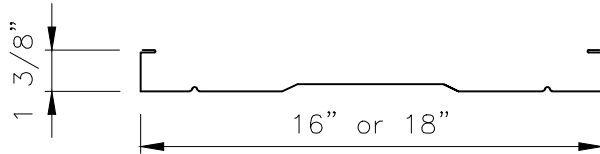

PLANK & PENCIL PROFILE (Standard)

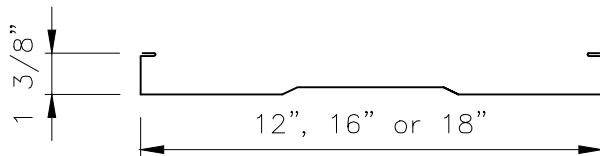

PLANK PROFILE

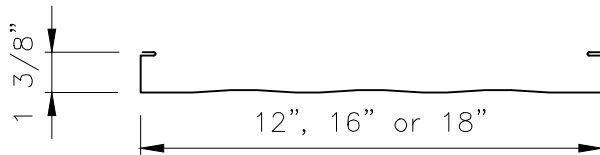

STRIATED PROFILE

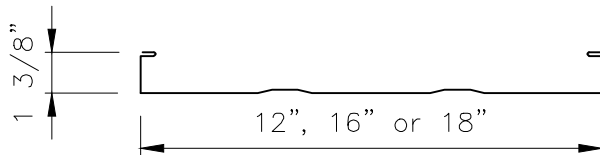

MINOR RIBS PROFILE

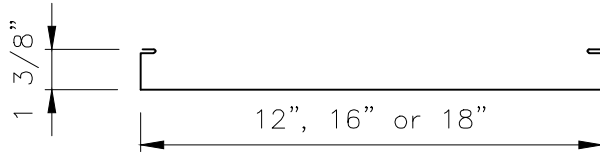

FLAT PROFILE

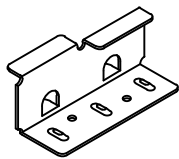

STANDARD CLIP

16 GA. Galvanized G90 - ASTM A635 (50 ksi)
16 GA. Stainless 304SS - ASTM A240 (50 ksi)

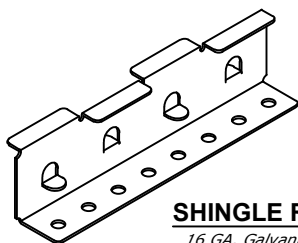

SHINGLE RECOVER / ASV CLIP

16 GA. Galvanized G90 - ASTM A635 (50 ksi)
16 GA. Stainless 304SS - ASTM A240 (50 ksi)

Applications

Symmetrical roof/wall panel used on slopes down to 1:12. Continuous length up to 80'. Convex curving only - 10ft minimum radius.

Substrates

Solid Wood Decking or Metal Deck

Material

Standard - 24 GA. ASTM A792 (50 ksi)
Optional - 22 GA. ASTM A792 (50 ksi)
- .040 Aluminum ASTM B209 3003
- 20oz. & 16oz. Copper ASTM B307 cold-rolled sheet
H00 or H01 Temper ****Special Order/Houston Plant Only****

Manufacturing

Roll formed in factory or at jobsite.

Finishes

Acrylic Coated Galvalume®
Fluoropolymer (Kynar 500® PVDF resin-based)

Pan Conditions

Plank & Pencil Rib, Plank, Striated, Minor Ribs and Flat
(Oil canning is inherent in all metal panels and is not cause for panel rejection. A signed oil canning acknowledgement will be required for all orders prior to production.)

Testing *

Uplift: UL 580, UL 1897, ASTM E1592
Air & Water Infiltration: ASTM E1680, ASTM E1646
Florida Product Approval: FL 22330 (Shingle Recover System)
Impact Resistance: UL Class 4, FM Class 1-SH
Texas Department of Insurance# RC-664 (for 16" Panel in 0.040" Aluminum only)
Testing and Approvals are product specific. Please inquire for details.

NOTE:

All data represented on this sheet may not be applicable to all widths and gauges. Please contact McElroy Metal for more information.

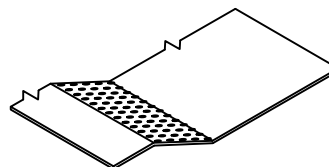

VENTED EAVE/RIDGE TRIM for 138T

0.063 Aluminum - ASTM B209 3003

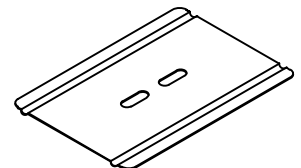

BEARING PLATE

24 GA. - ASTM A792 (50 ksi)

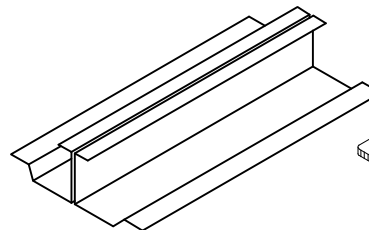

MULTI-SPAN CLIP

2-Piece

Standard: 24 GA. - ASTM A792 (50 ksi)
Optional: 22 GA. - ASTM A792 (50 ksi)

Typically sold in 10' lengths

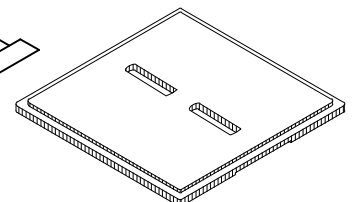

STACKABLE LEVELING SHIM

6" x 6" x 1/4" Thick

138T Symmetrical Panel (Continued)

Product Data

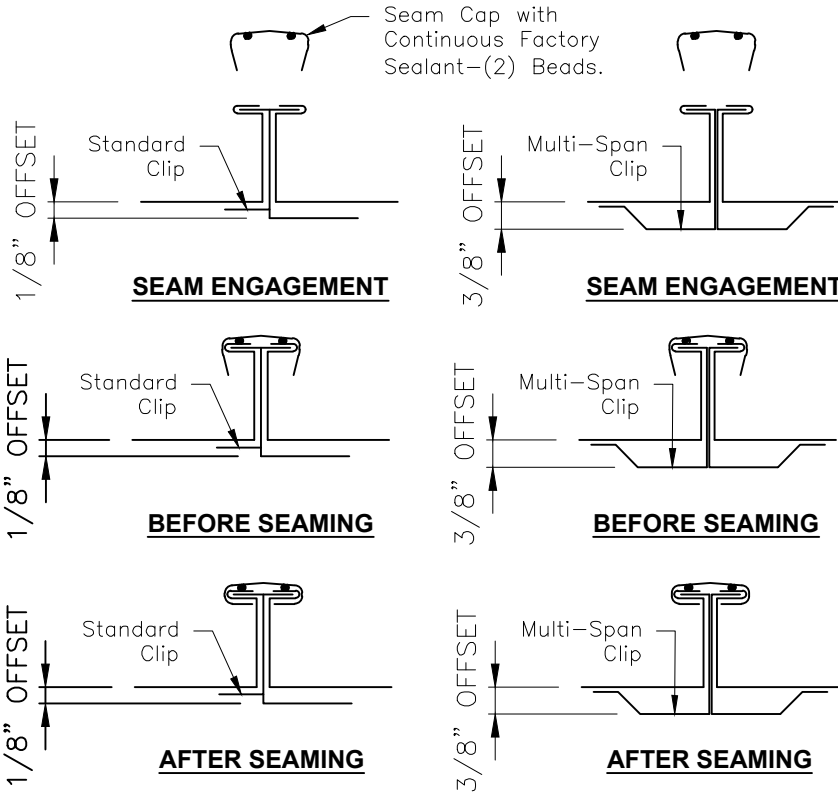

MECHANICAL SEAMER

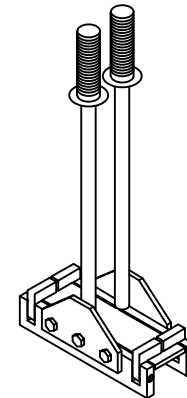

HAND SEAMER

NOTE:

All data represented on this sheet may not be applicable to all widths and gauges. Please contact McElroy Metal for more information.

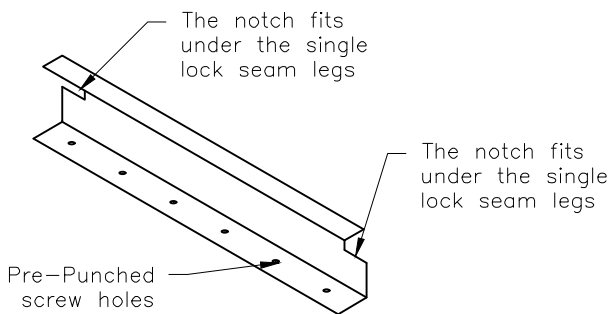

CLOSURE

Optimum Widths 16"
Additional lengths for hips available.
24 GA. - ASTM A792 (50 ksi)

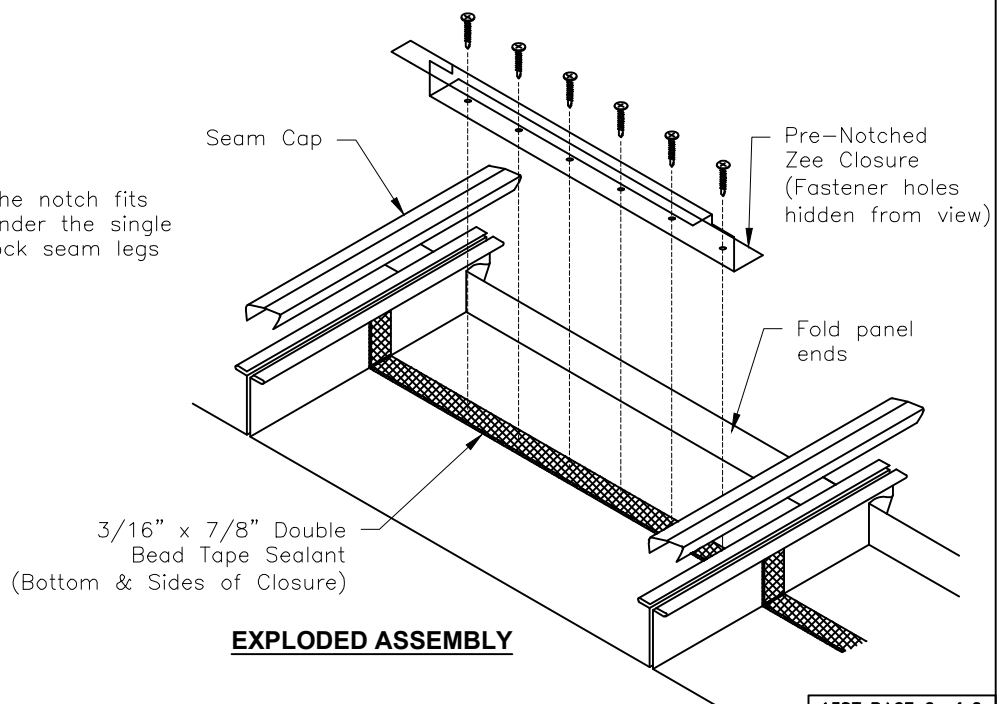

EXPLODED ASSEMBLY

138T

INSTALLATION

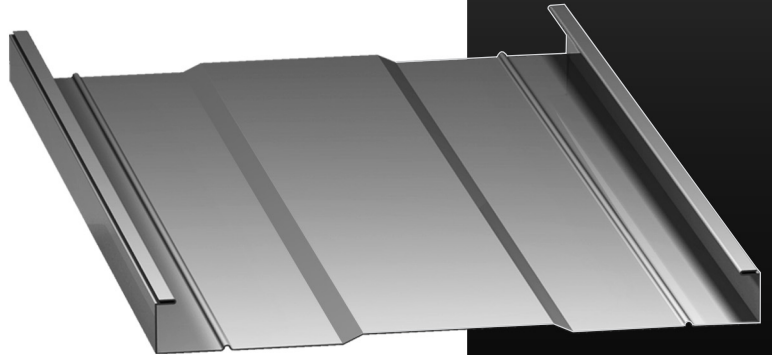

TABLE OF CONTENTS

PAGE NUMBER:	DETAIL DESCRIPTION
A-1.....	TABLE OF CONTENTS
A-2.....	GENERAL NOTES
B-1.....	GENERAL INFORMATION
C-1.....	EAVE DRIP DETAIL
C-2.....	EAVE DRIP with GUTTER DETAIL
C-3 & C-4.....	FIXED RIDGE DETAIL
C-5 & C-6.....	FIXED HIGH-SIDE EAVE DETAIL
C-7 & C-8.....	FIXED HIGH-SIDE TIE-IN DETAIL
C-9.....	FLOATING RAKE DETAIL
C-10.....	FLOATING RAKE DETAIL (ALTERNATE)
C-11.....	FLOATING SIDE-WALL TIE-IN DETAIL
C-12 & C-13.....	VALLEY DETAIL
C-14 & C-15.....	FIXED HIP DETAIL
C-16.....	DEKTITE DETAIL
C-17 thru C-21.....	CURB INSTALLATION DETAILS
C-22 & C-23.....	TRIM LAP DETAILS

GENERAL NOTES

The details shown on the following pages are suggestions or guidelines for installing the 138T roof panel system. The installation details shown here are proven methods of construction, but they are not intended to cover all building requirements, designs or codes. The details may require changes or revisions due to individual project conditions. In addition, other details may be perfectly acceptable for use. Please contact McElroy Metal for assistance in determining if a detail is acceptable.

Installation procedures shall be in accordance with the manufacturer's printed instructions, details or approved shop drawings. Installers should thoroughly familiarize themselves with all instructions prior to beginning the installation process.

The designer/installer is responsible to ensure the following:

That the details here meet the particular building requirements.

Awareness of and allowance for expansion/contraction of the roof panels.

That adequate water tightness is maintained.

That a proper uniform substructure is used to avoid panel distortion and that the substructure meets necessary code requirements.

That all supporting members have been examined and are straight, level and plumb.

McElroy Metal can provide all flashings and accessories shown in the installation drawings unless noted otherwise. Panels, flashing and trim shall be installed true and in proper alignment with any exposed fasteners equally spaced for the best appearance. Sealant shall be field applied on a clean, dry surface.

Some field cutting and fitting of panels and flashings is to be expected and to be considered a part of normal installation work. Workmanship shall be of the best industry standards and with installation performed by experienced metal craftsmen.

Oil canning of metal panels is inherent in the product and is not a cause for rejection. Plank and Pencil Rib panels are recommended as to reduce the appearance of oil canning.

Contents of this manual are subject to change without notice. To confirm this book is the most current copy, please visit McElroy Metal's website at www.mcelroymetal.com.

Optional details can also be found on our website.

GENERAL INFORMATION

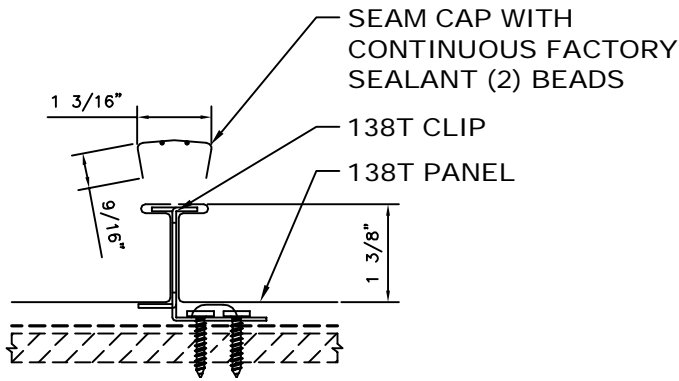

SEAM ENGAGEMENT

NOTE:
ALL DIMENSIONS ARE APPROXIMATE.
SLIGHT DIFFERENCES IN THE FIELD
ARE ACCEPTABLE.

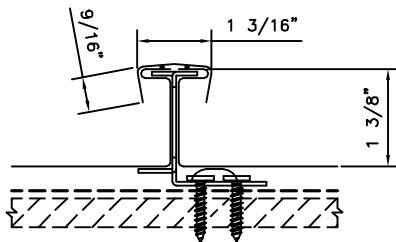

BEFORE SEAMING

NOTE:
ALL DIMENSIONS ARE APPROXIMATE.
SLIGHT DIFFERENCES IN THE FIELD
ARE ACCEPTABLE.

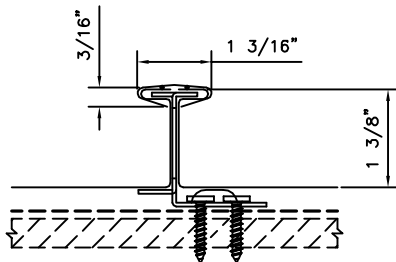

AFTER SEAMING

NOTE:
ALL DIMENSIONS ARE APPROXIMATE.
SLIGHT DIFFERENCES IN THE FIELD
ARE ACCEPTABLE.

NOTE:

Mechanical seamers and hand seamers are available for rental through McElroy's approved seamer supplier at the following website. Go to: <http://www.mcelroyseamers.com>

!!!ATTENTION!!!

If a panel or seam becomes damaged, the installer can rent a "de-seamer" through the same website listed above.

ATTENTION

READ THE SEAMER INFORMATION THOROUGHLY BEFORE STARTING THE SEAMING OPERATION. FAILURE TO ADHERE TO THESE INSTRUCTIONS MAY RESULT IN PERSONAL INJURY AND DAMAGE TO THE SEAMER AND/OR PANELS. THE ERECTOR WILL BE HELD LIABLE FOR ANY COSTS INCURRED FOR REPLACEMENT OR REPAIR.

PRE-SEAMING INFORMATION

1. Locate seamer box. Check to make sure you received an electric seamer, parts box, return shipping label and an information booklet. If not, please call our Technical Services Department. (Hand Seamers must be rented.)
2. Locate power source and check against power requirements in the information booklet.
3. Check seams for proper engagement.
4. Clean dirt, debris and excess sealant from seams and panel surfaces to avoid interfering with the seaming operation.

HAND SEAMING OPERATION

!!!ATTENTION!!!

It is critical that the panel seams are crimped and folded before using the electric seamer. Failure to follow these guidelines will result in damaged seams.

To begin seaming, set the hand seamer on the seam. Align the edge of the hand seamer about one to two inches past the edge of the panel. Crimp the panel 3 to 4 times along the seam for a total of 12" at the eave and 5 or 6 times along the seam for a total of 18" at the ridge and then at every clip.



CAUTION: The use of any seaming machine or tools other than that recommended by the manufacturer, may damage the panels, void all warranties and will void all engineering data.

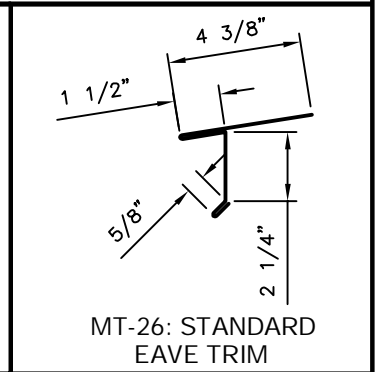
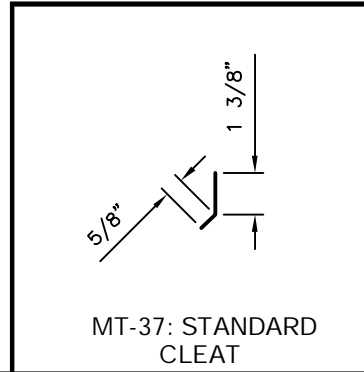
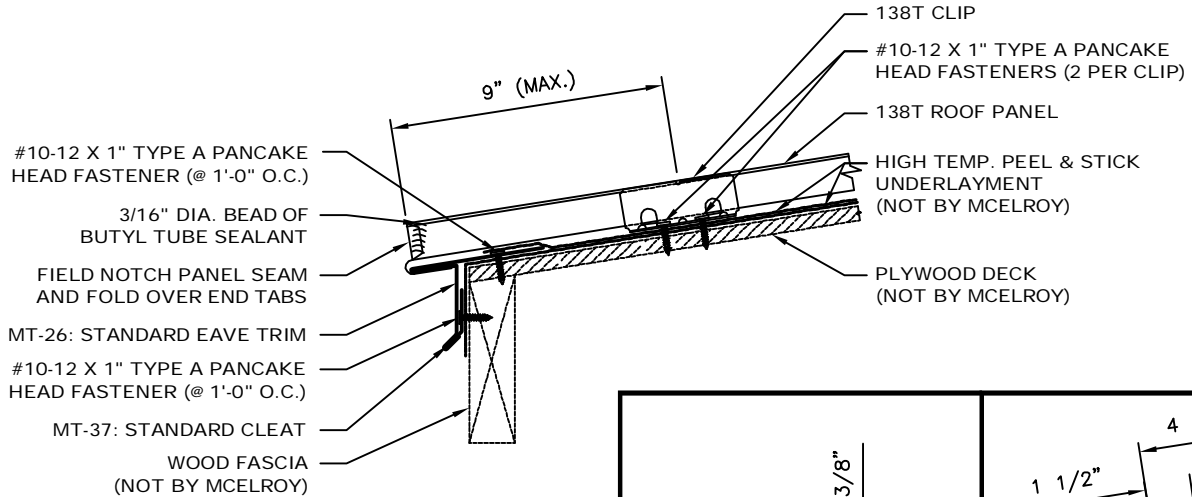

- NOTES: 1. MT-26 (Standard Eave Trim) and MT-37: (Standard Cleat) to run from out of wall to out of wall.
 2. Attach MT-37 (Standard Cleat) to wood fascia with #10-12 x 1" Type A Pancake Head Fasteners @ 1'-0" O.C.
 3. Attach MT-26: (Standard Eave Trim) onto 24GA. MT-37 (Standard Cleat) and then attach to Plywood Decking with #10-12 x 1" Type A Pancake Head Fasteners @ 1'-0" O.C.
 4. Trim pieces lap 2". Apply 3/32" x 3/8" Butyl Tape or Butyl Tube Sealant in trim laps.
 5. Place a 3/16" Dia. Bead of Butyl Tube Sealant to leading edge of 138T panel.
 6. Field Notch panel seam and fold over end tabs of panels.

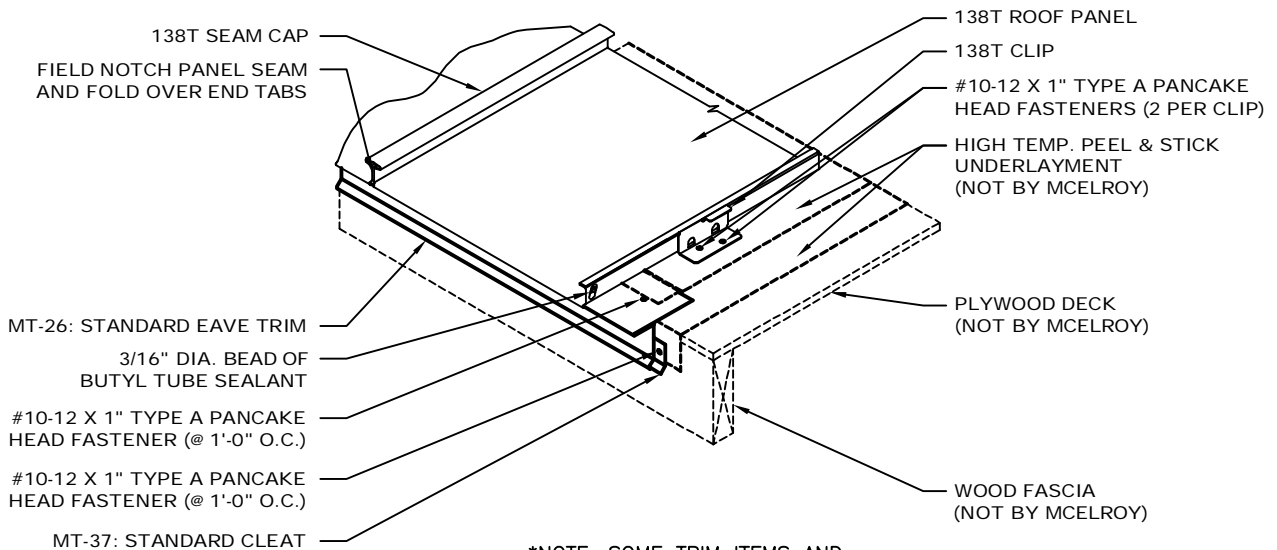

*NOTE: SOME TRIM ITEMS AND FASTENERS HAVE BEEN REMOVED FOR CLARITY OF ISOMETRIC DETAIL.

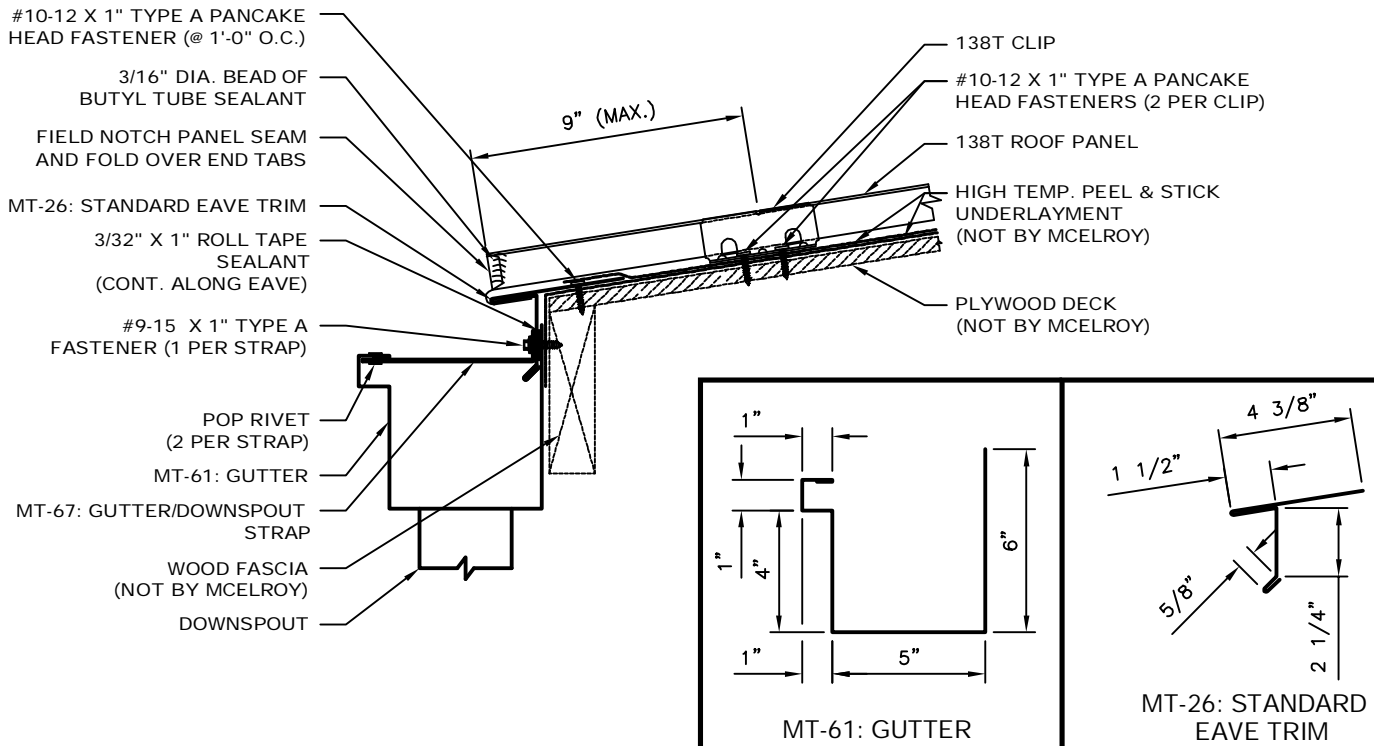

- NOTES: 1. MT-26 (Standard Eave Trim) and MT-61 (Gutter) to run from out of wall to out of wall.
 2. Apply a continuous bead of 3/32" x 1" Roll Tape Sealant to the inside vertical leg of the Gutter. Attach MT-67 (Gutter Straps) and Gutter with (2) Pop Rivets as shown in detail.
 3. Attach MT-26 (Standard Eave Trim) to decking with #10-12 x 1" Type A Pancake Head Fasteners @ 1'-0" O.C. Slide vertical leg of Gutter behind MT-26 (Standard Eave Trim) and fasten through Gutter Strap, Standard Eave Trim, Tape Sealant and Gutter with a #9-15 x 1" HWH Type A Fastener into Fascia Board per Gutter Strap spacing.
 4. Trim pieces lap 2". Apply 3/32" x 3/8" Butyl Tape or Butyl Tube Sealant in trim laps.
 5. Place a 3/16" Dia. Bead of Butyl Tube Sealant to leading edge of 138T panel.
 6. Field Notch panel seam and fold over end tabs.

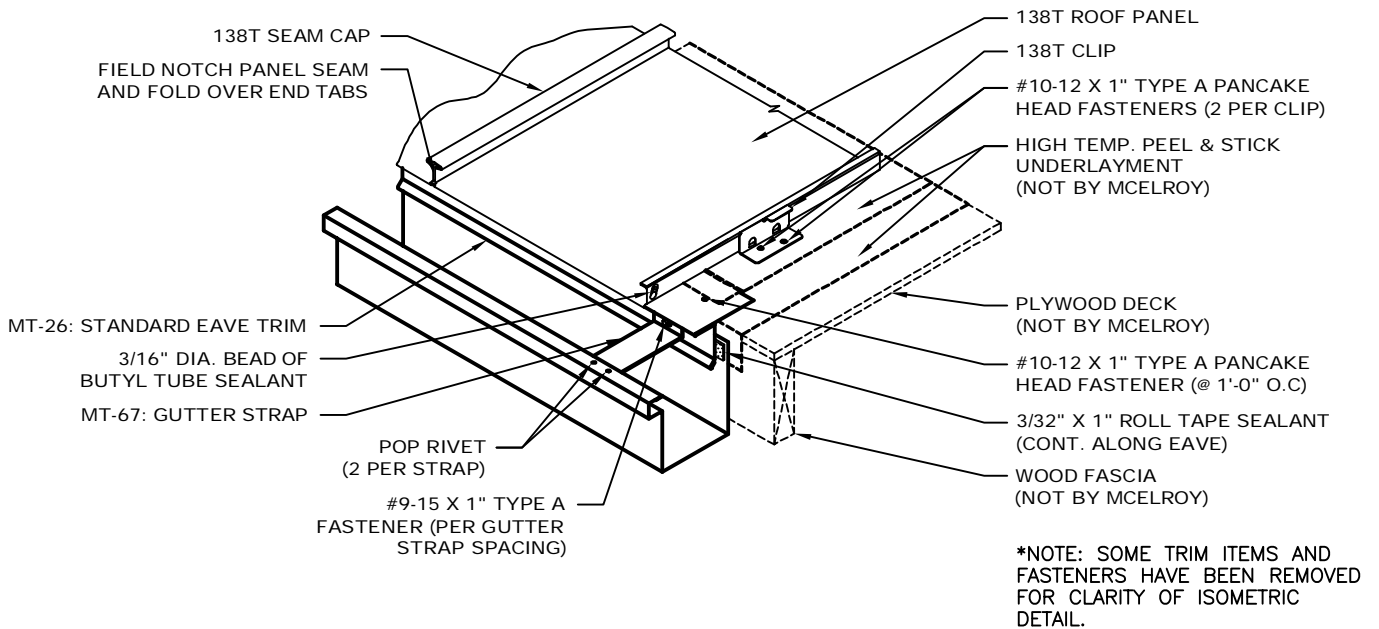

*NOTE: SOME TRIM ITEMS AND FASTENERS HAVE BEEN REMOVED FOR CLARITY OF ISOMETRIC DETAIL.

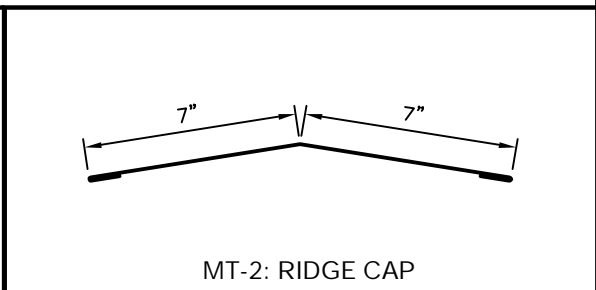
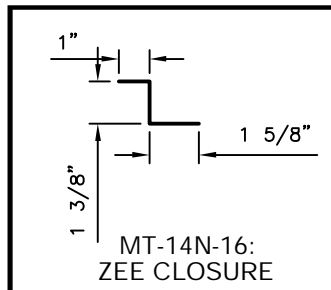
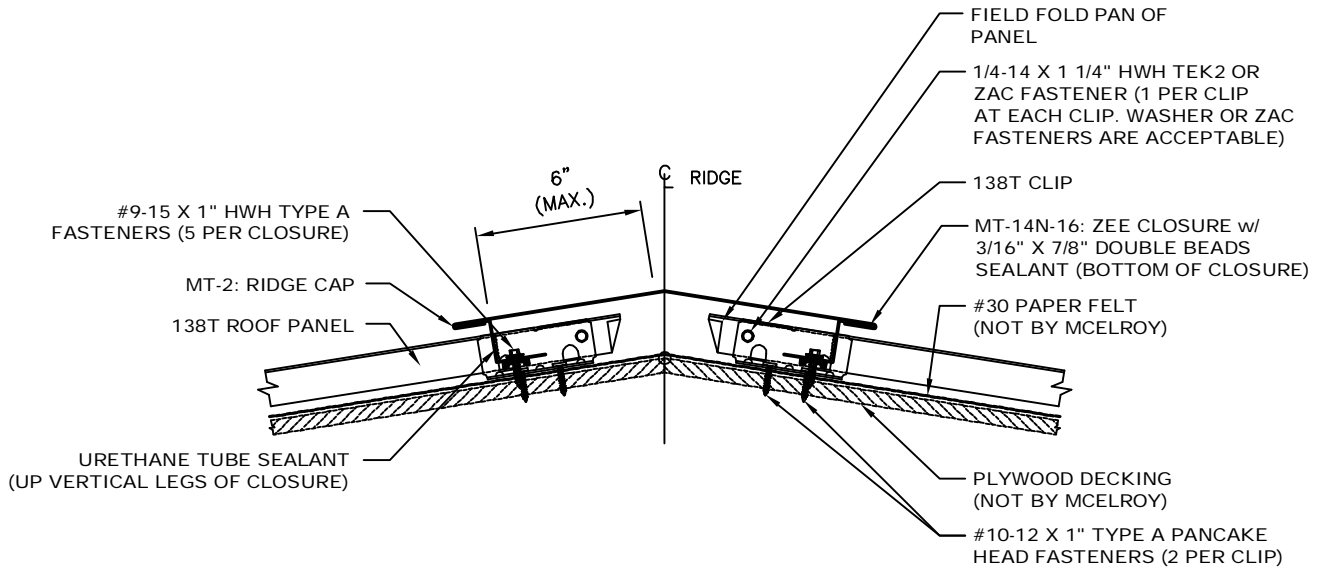

- NOTES:
1. MT-2 (Ridge Cap) to run from out of wall to out of wall.
 2. Using a panning tool, fold up the pan of the panel at the ridge.
 3. Install 138T panels and apply a line of 3/16" x 7/8" Double Bead Sealant in the pan of the panel.
 4. Install MT-14N-16 (Zee Closure) and seal vertical legs of closure and panel with Urethane Tube Sealant. Fix panels to clips with (1) 1/4-14 x 1 1/4" HWH Tek2 or ZAC Fastener, making sure to fasten through the clip.
 5. MT-2 (Ridge Cap) laps 2". Apply 3/32" x 1" Butyl Tape and Pop Rivet trims to MT-14 (Zee Closure) with Pop Rivets at Laps.

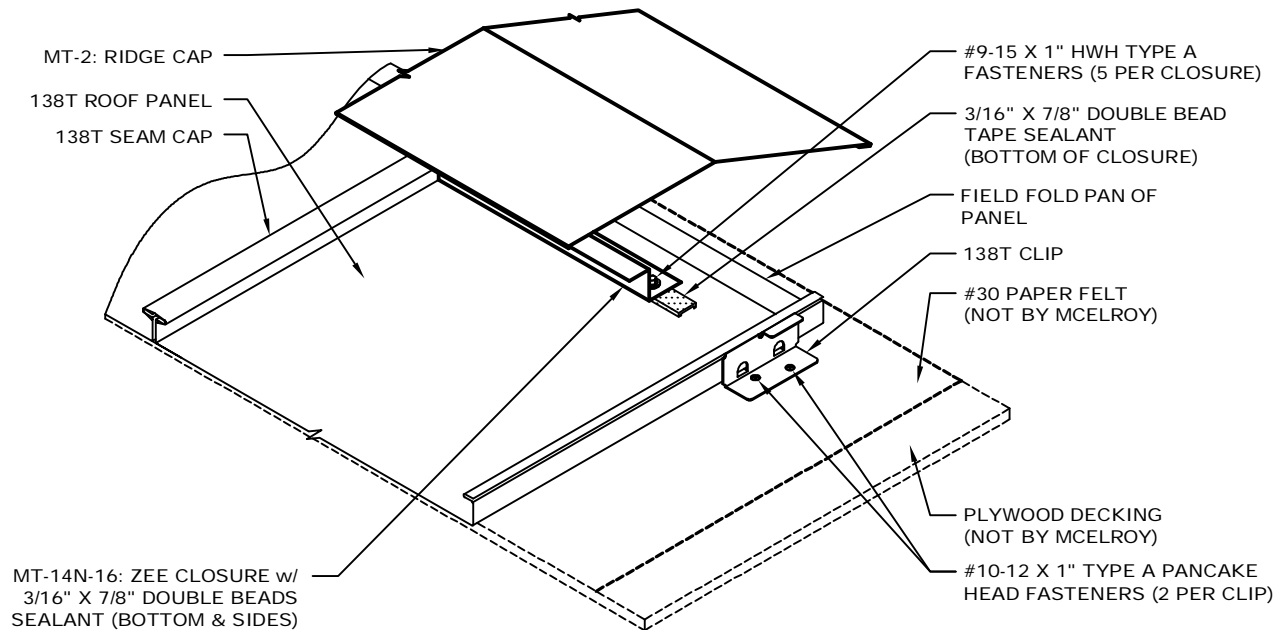

*NOTE: SOME TRIM ITEMS AND FASTENERS HAVE BEEN REMOVED FOR CLARITY OF ISOMETRIC DETAIL.

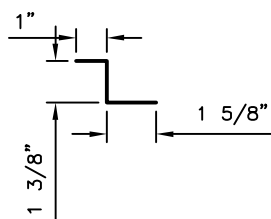

MT-14N-16:
ZEE CLOSURE



MT-2: RIDGE CAP

- NOTES:
1. MT-2 (Ridge Cap) to run from out of wall to out of wall.
 2. Using a panning tool, fold up the pan of the panel at the ridge.
 3. Install 138T panels and apply a line of 3/16" x 7/8" Double Bead Sealant in the pan of the panel.
 4. Install MT-14N-16 (Zee Closure) and seal vertical legs of closure and panel with Urethane Tube Sealant. Fix panels to clips with (1) 1/4-14 x 1 1/4" HWH Tek2 or ZAC Fastener, making sure to fasten through the clip.
 5. MT-2 (Ridge Cap) laps 2". Apply 3/32" x 1" Butyl Tape and Pop Rivet trims to MT-14 (Zee Closure) with Pop Rivets at Laps.

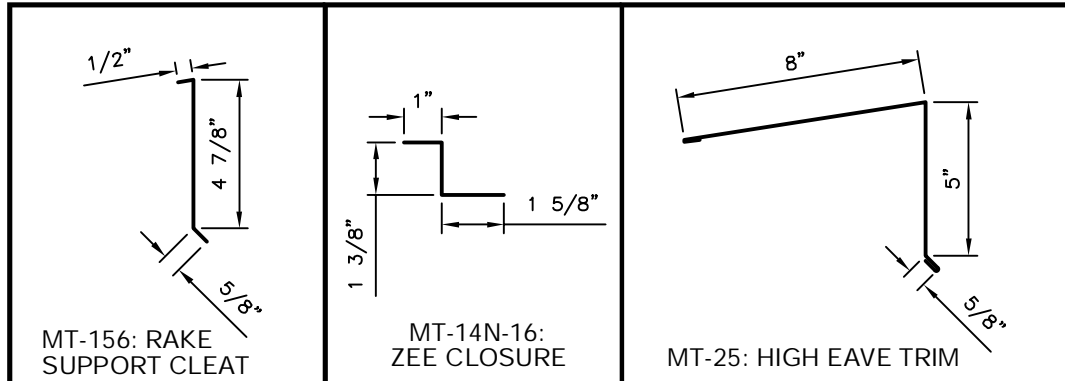
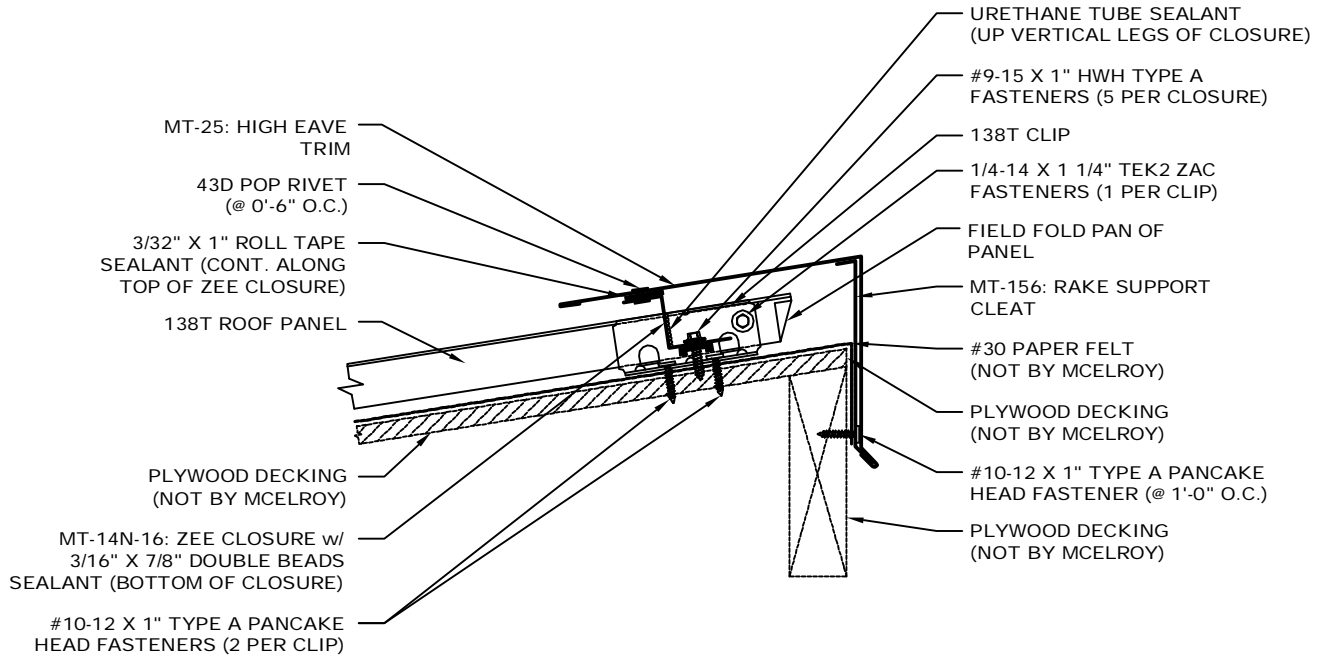

- NOTES:
1. MT-25 (High Eave Trim), MT-156 (Rake Support Cleat) and MT-38 (Standard Offset Cleat) to run from out to out of building.
 2. Using a panning tool, fold up the pan of the panel at the high eave.
 3. Attach MT-156 (Rake Support Cleat) to fascia board with #10-12 x 1" Type A Pancake Head Fasteners at 1'-0" O.C.
 4. Install 138T panels and apply a line of 3/16" x 7/8" Double Bead Sealant in the pan and vertical legs of the panel.
 5. Install MT-14N-16 (Zee Closure) and seal vertical legs of closure and panel with Urethane Tube Sealant. Fix panels to clips with (1) 1/4-14 x 1 1/4" HWH Tek2 or ZAC Fastener, making sure to fasten through the clip.
 6. MT-25 (High Eave Flashing) laps 2". Apply 3/32" x 1" Butyl Tape and Pop Rivet trims to Zee Closure with Pop Rivets at 0'-6" O.C.

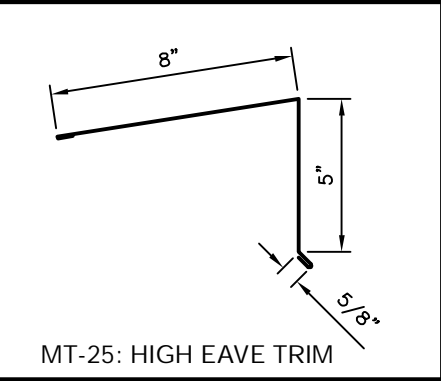
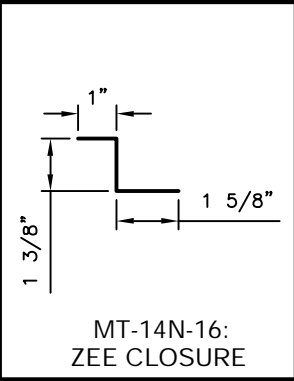
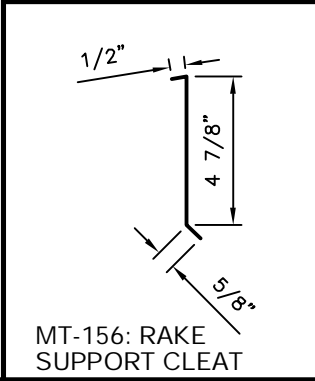
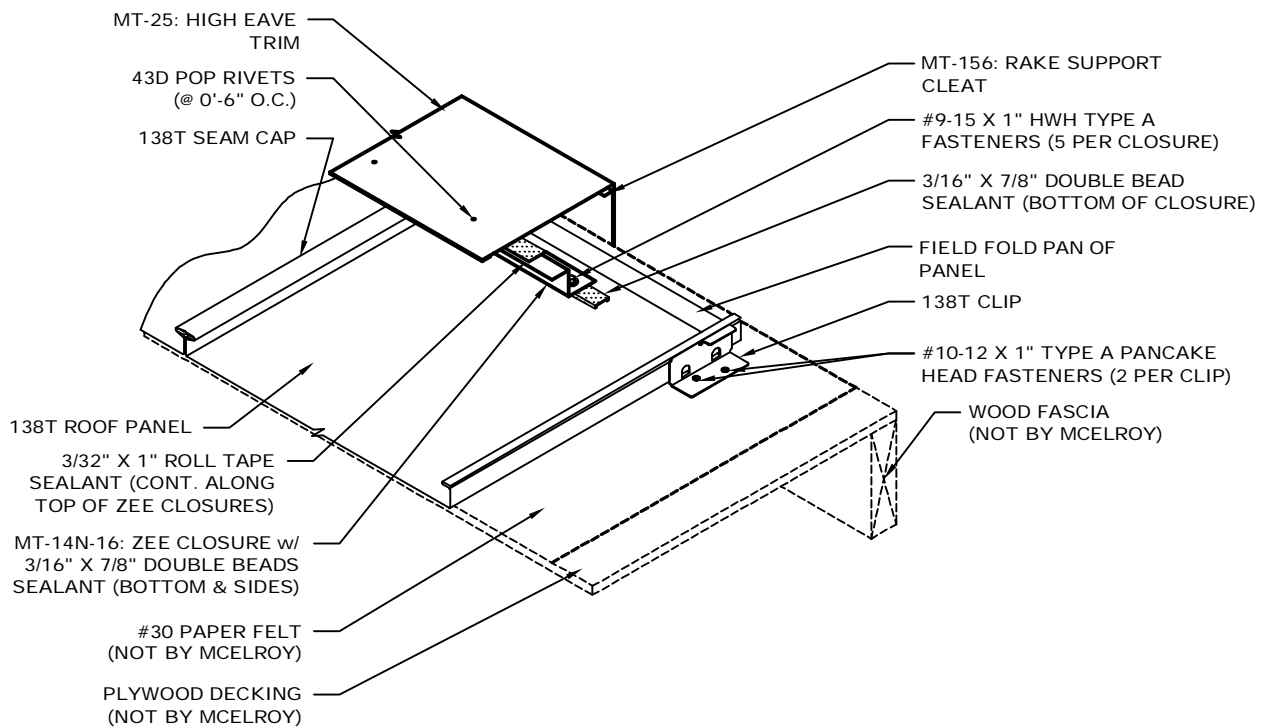

*NOTE: SOME TRIM ITEMS AND FASTENERS HAVE BEEN REMOVED FOR CLARITY OF ISOMETRIC DETAIL.

- NOTES: 1. MT-25 (High Eave Trim), MT-156 (Rake Support Cleat) and MT-38 (Standard Offset Cleat) to run from out to out of building.
 2. Using a panning tool, fold up the pan of the panel at the high eave.
 3. Attach MT-156 (Rake Support Cleat) to fascia board with #10-12 x 1" Type A Pancake Head Fasteners at 1'-0" O.C.
 4. Install 138T panels and apply a line of 3/16" x 7/8" Double Bead Sealant in the pan and vertical legs of the panel.
 5. Install MT-14N-16 (Zee Closure) and seal vertical legs of closure and panel with Urethane Tube Sealant. Fix panels to clips with (1) 1/4-14 x 1 1/4" HWH Tek2 or ZAC Fastener, making sure to fasten through the clip.
 6. MT-25 (High Eave Trim) laps 2". Apply 3/32" x 1" Butyl Tape and Pop Rivet trims to MT-14N-16 (Zee Closure) with Pop Rivets at 0'-6" O.C.

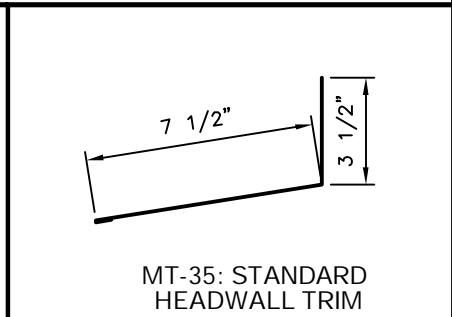
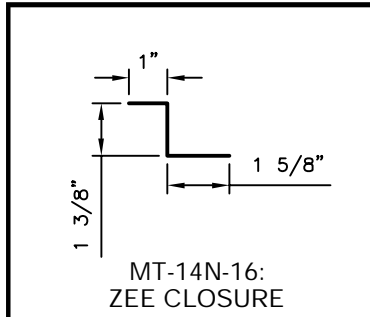
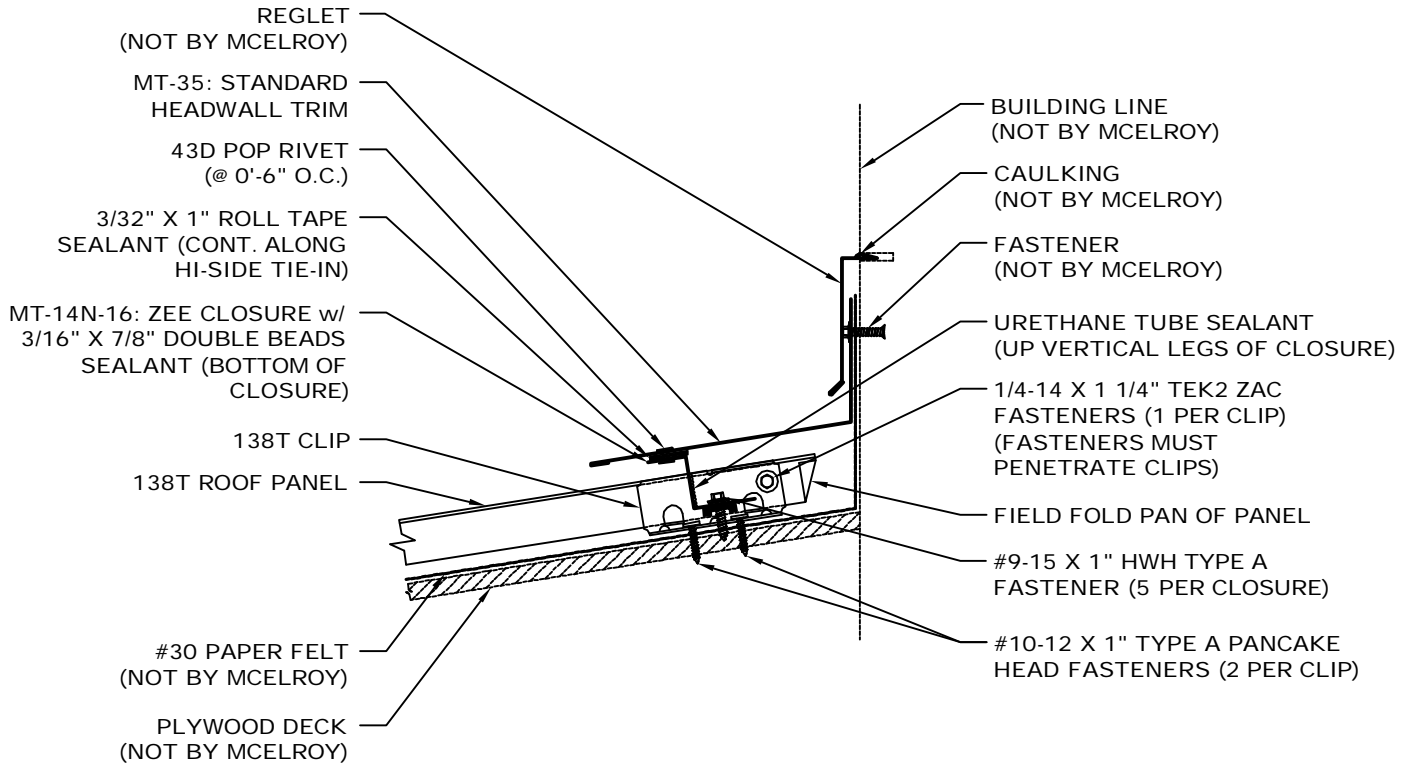

- NOTES: 1. MT-35 (Standard Headwall Trim) to run from out to out of building.
 2. Using a panning tool, fold up the pan of the panel at the high eave.
 3. Install 138T panels and apply a line of 3/16" x 7/8" Double Bead Sealant in the pan of the panel.
 4. Install MT-14N-16 (Zee Closure) and seal vertical legs of closure and panel with Urethane Tube Sealant. Fix panels to clips with (1) 1/4-14 x 1 1/4" HWH Tek2 or ZAC Fastener, making sure to fasten through the clip.
 5. MT-35 (Standard Headwall Trim) to lap 2". Apply 3/32" x 3/8" Butyl Tape or Butyl Tube Sealant in trim laps and attach to Zee Closure with Pop Rivets. MT-38 (Standard Offset Cleat) will butt joint.

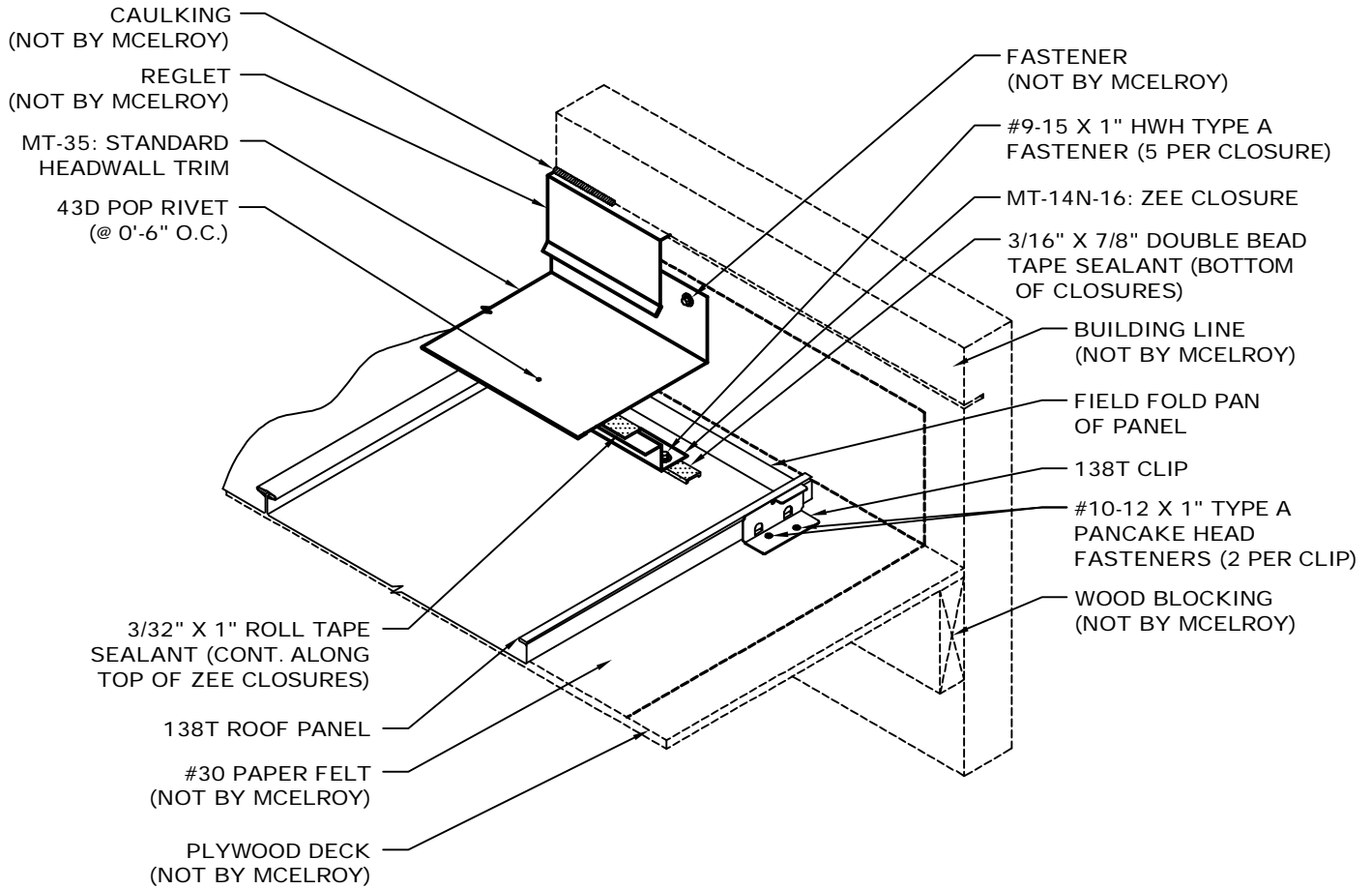

*NOTE: SOME TRIM ITEMS AND FASTENERS HAVE BEEN REMOVED FOR CLARITY OF ISOMETRIC DETAIL.

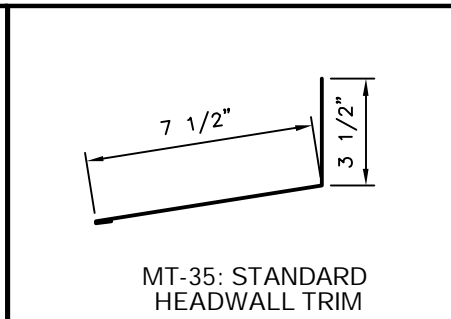
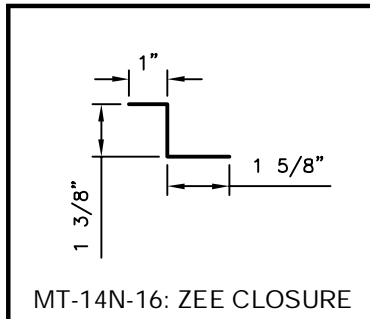

- NOTES:
1. MT-35 (Standard Headwall Trim) to run from out to out of building.
 2. Using a panning tool, fold up the pan of the panel at the high eave.
 3. Install 138T panels and apply a line of 3/16" x 7/8" Double Bead Sealant in the pan of the panel.
 4. Install MT-14N-16 (Zee Closure) and seal vertical legs of closure and panel with Urethane Tube Sealant. Fix panels to clips with (1) 1/4-14 x 1 1/4" HWH Tek2 or ZAC Fastener, making sure to fasten through the clip.
 5. MT-35 (Standard Headwall Trim) to lap 2". Apply 3/32" x 3/8" Butyl Tape or Butyl Tube Sealant in trim laps and attach to trim with Pop Rivets. MT-38 (Standard Offset Cleat) will butt joint.

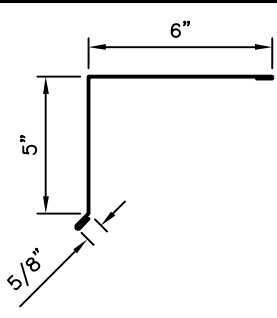
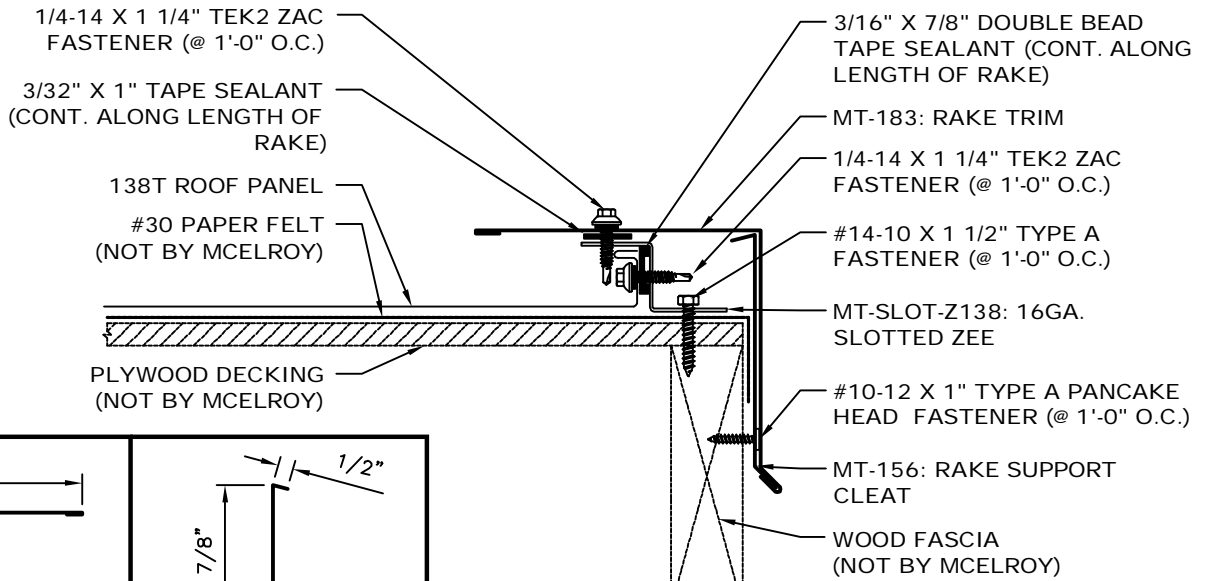

MT-183: RAKE TRIM

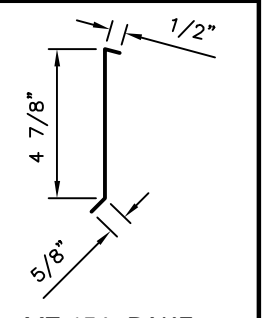

MT-156: RAKE SUPPORT CLEAT

- NOTES: 1. MT-183 (Rake Trim), MT-156 (Rake Support Cleat) and MT-SLOT-Z138 (16ga. Slotted Zee) to run from eave to ridge.
2. Attach MT-SLOT-Z138 (16ga. Slotted Zee) to decking with #14-10 x 1 1/2" HWH Type A Fasteners at 1'-0" O.C.
3. Apply a continuous bead of 3/16" x 7/8" Double Bead Tape Sealant to the vertical leg of the 138T panel. Install 138T panel and hold in place on the Slotted Zee with clamps. Fasten panel to Slotted Zee with 1/4-14 x 1 1/4" Tek2 ZAC Fasteners at 1'-0" O.C.
4. Apply a continuous bead of 3/32" x 1" Roll Tape Sealant to the top of the Slotted Zee and attach MT-183 (Rake Trim) with 1/4-14 x 1 1/4" Tek2 ZAC Fasteners at 1'-0" O.C.
5. Trim pieces lap 2". Apply 3/32" x 3/8" Butyl Tape or Butyl Tube Sealant in trim laps.

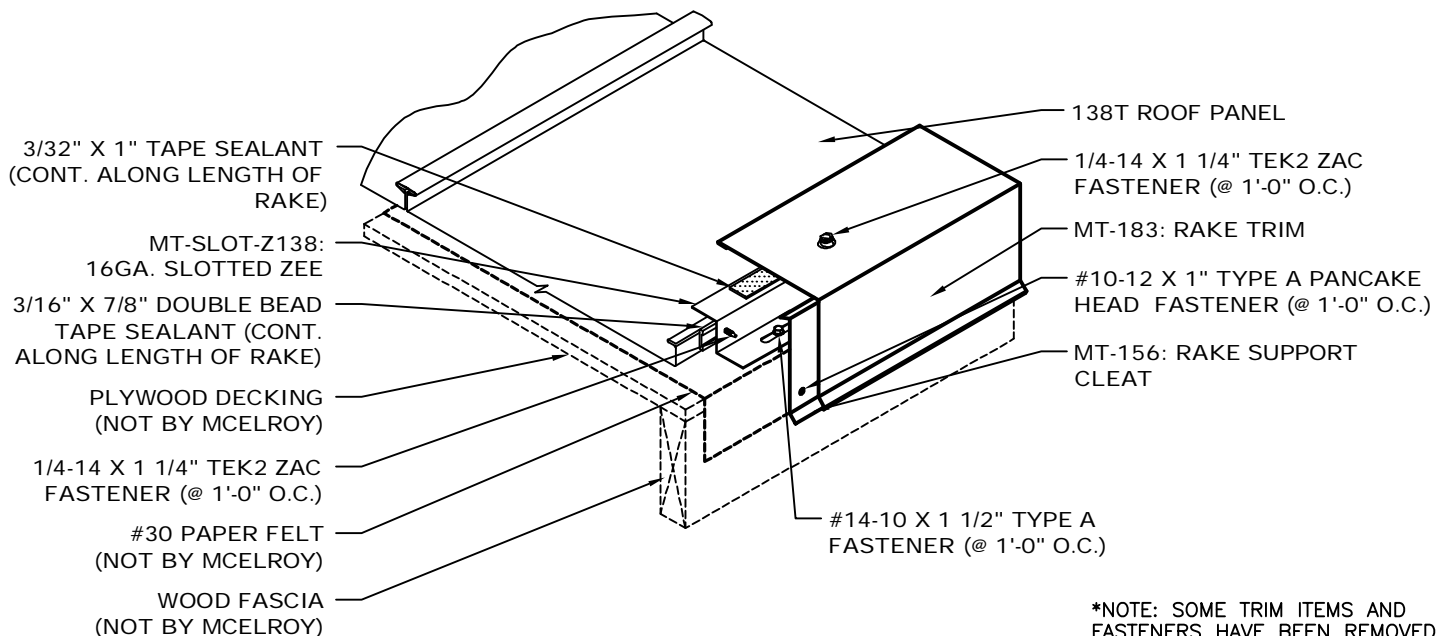

*NOTE: SOME TRIM ITEMS AND FASTENERS HAVE BEEN REMOVED FOR CLARITY OF ISOMETRIC DETAIL.

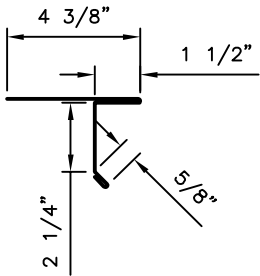
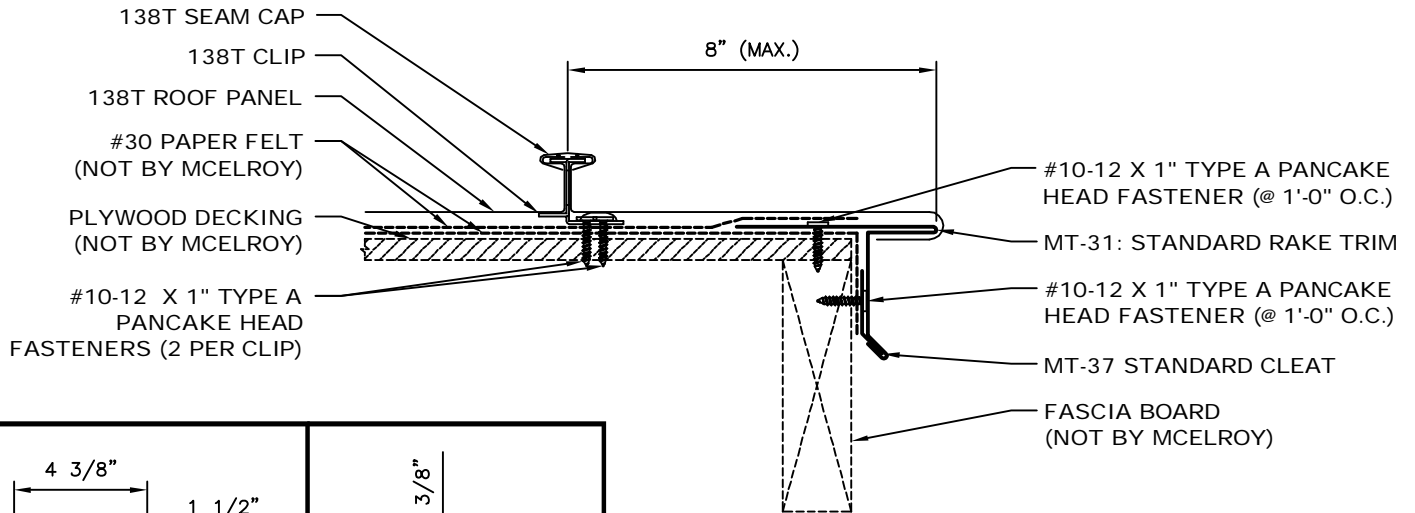

MT-31: STANDARD RAKE TRIM

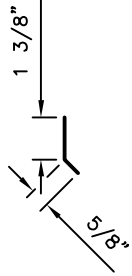

MT-37: STANDARD CLEAT

- NOTES: 1. MT-31 (Rake Trim) and MT-37 (Standard Cleat) to run from eave to ridge.
 2. Attach MT-37 (Standard Cleat) to Fascia Board with #10-12 x 1" Type A Pancake Head Fasteners at 1'-0" O.C.
 3. Attach MT-31 (Rake Trim) to MT-37 (Standard Cleat) and fasten to Plywood Decking with #10-12 x 1" Type A Pancake Head Fasteners at 1'-0" O.C.
 4. Field cut leading edge of panel and fold panel down 180°.

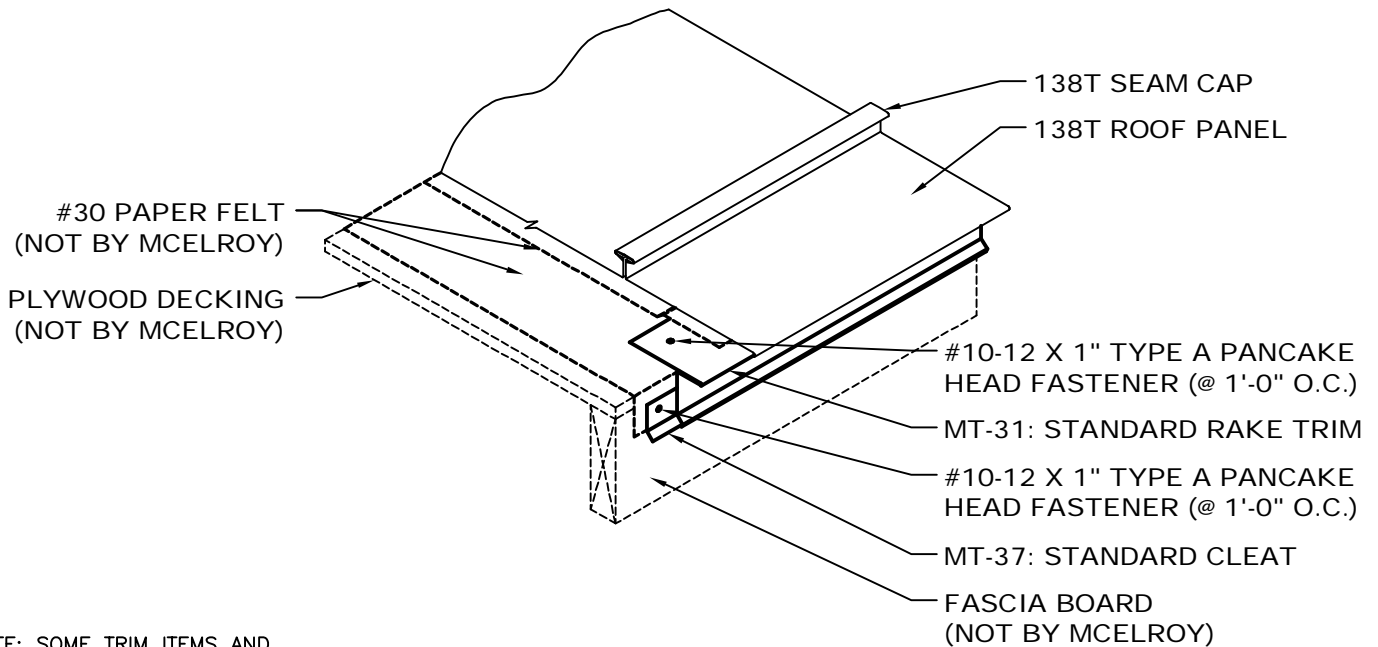

*NOTE: SOME TRIM ITEMS AND FASTENERS HAVE BEEN REMOVED FOR CLARITY OF ISOMETRIC DETAIL.

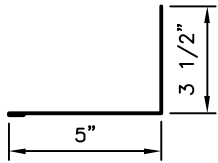
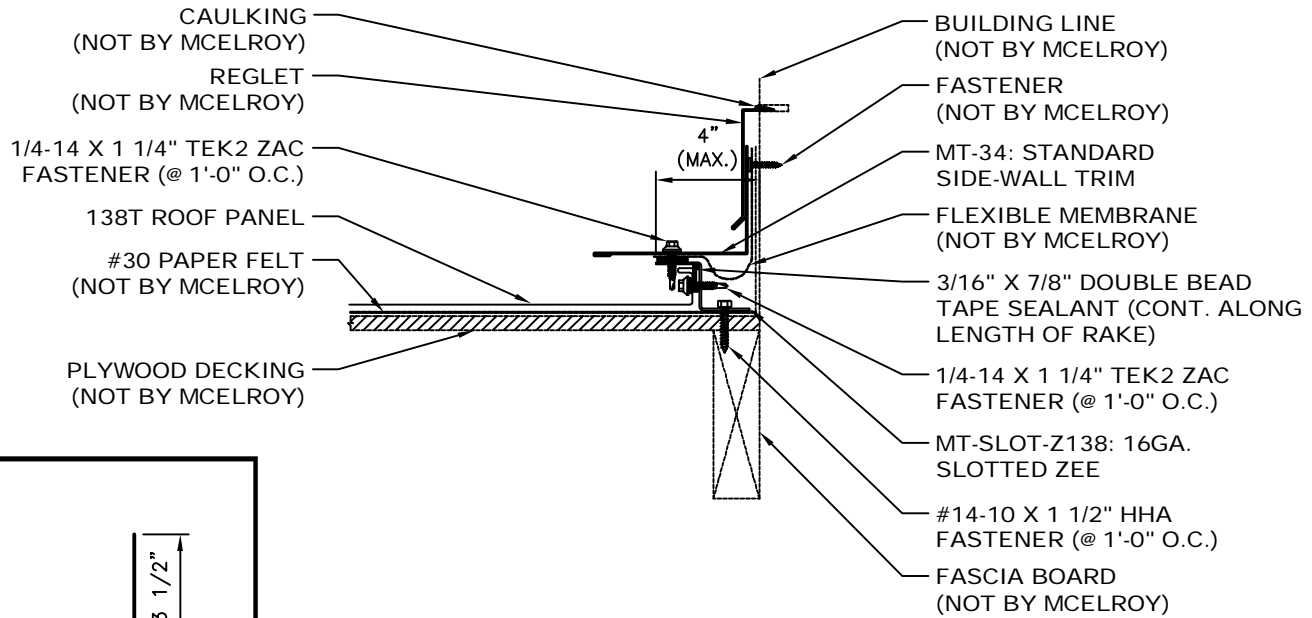

MT-34: STANDARD SIDE-WALL TRIM

- NOTES: 1. MT-34 (Standard Side-Wall Trim) to run from Eave to Ridge.
 2. Attach MT-SLOT-Z138 (16ga. Slotted Zee) to decking with #14-10 x 1 1/2" HWH Type A Fasteners at 1'-0" O.C.
 3. Apply a continuous run of 3/16" x 7/8" Double Bead Tape Sealant to the vertical leg of the 138T panel. Install 138T panel and hold in place on the Slotted Zee with clamps. Fasten panel to Slotted Zee with 1/4-14 x 1 1/4" Tek2 Zac Fasteners at 1'-0" O.C.
 4. Apply a continuous run of 3/32" x 1" Roll Tape Sealant to the top of the Slotted Zee and attach MT-34 (Standard Side-Wall Trim) with 1/4-14 x 1 1/4" Tek2 ZAC Fasteners at 1'-0" O.C.
 5. Trim pieces lap 2". Apply 3/32" x 3/8" Butyl Tape or Butyl Tube Sealant in trim laps.

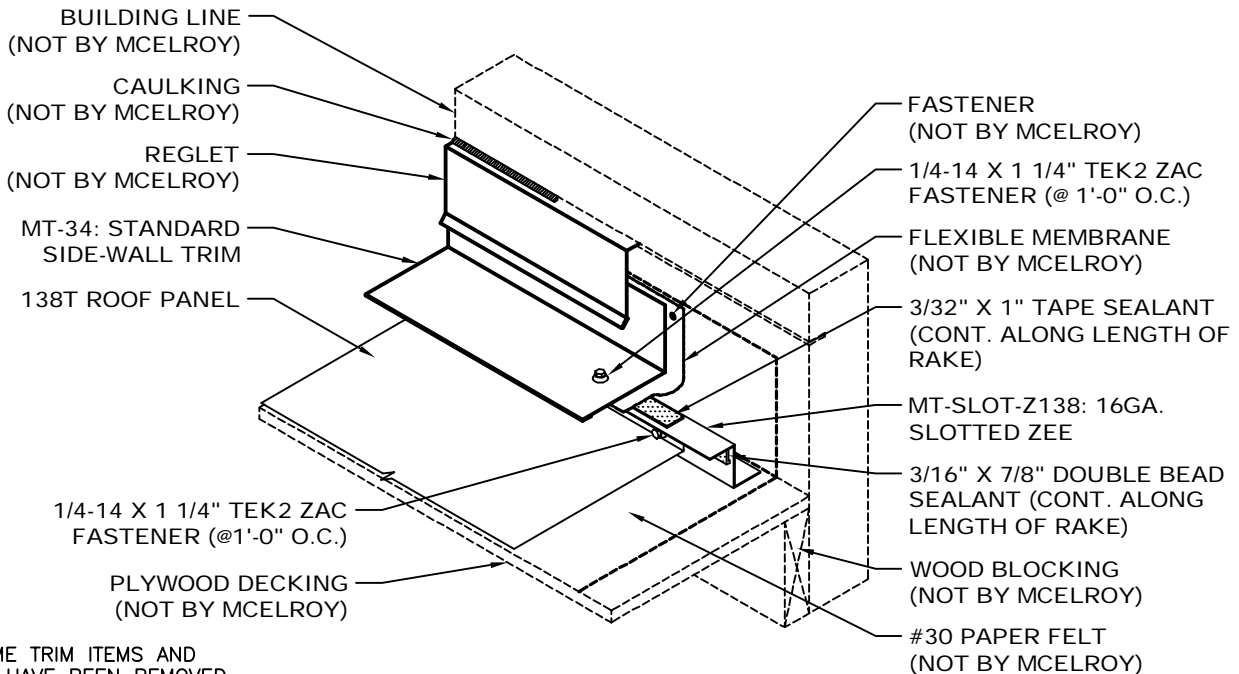

*NOTE: SOME TRIM ITEMS AND FASTENERS HAVE BEEN REMOVED FOR CLARITY OF ISOMETRIC DETAIL.

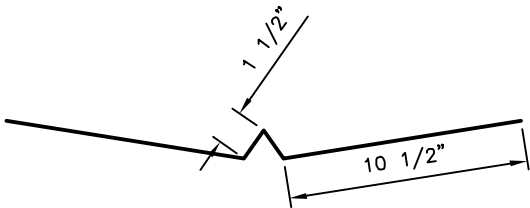
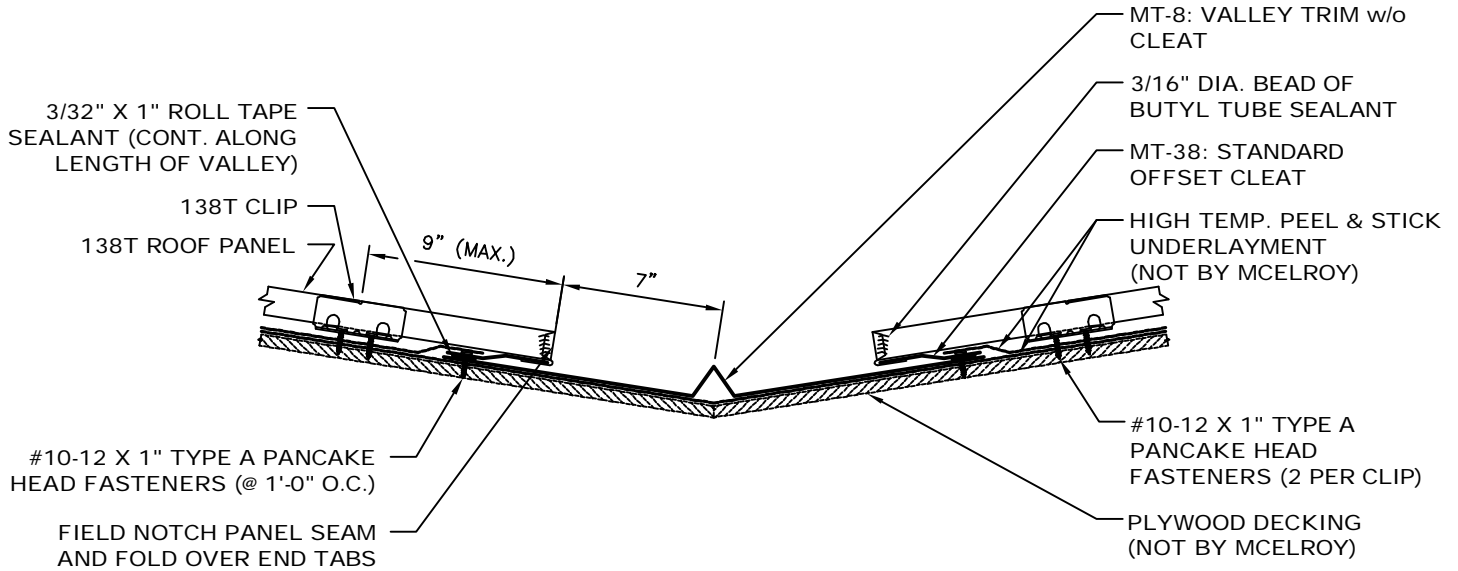

MT-8: VALLEY w/o CLEAT

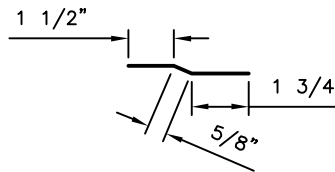

MT-38: STANDARD OFFSET CLEAT

- NOTES: 1. Install MT-8 (Valley w/o Cleat) from eave to ridge. Valley Trim pieces lap 6". Place 3/32" x 1" Butyl Tape or a 3/16" Dia. bead of Butyl Tube Sealant in laps.
2. Cut panels at required bevel for valley condition.
3. Apply a continuous line of 3/32" x 1" Roll Tape Sealant up both sides of MT-8 (Valley Trim w/o Cleat).
4. Attach MT-38 (Standard Offset Cleat) with #10-12 x 1" Type A Pancake Head Fasteners at 1'-0" O.C.

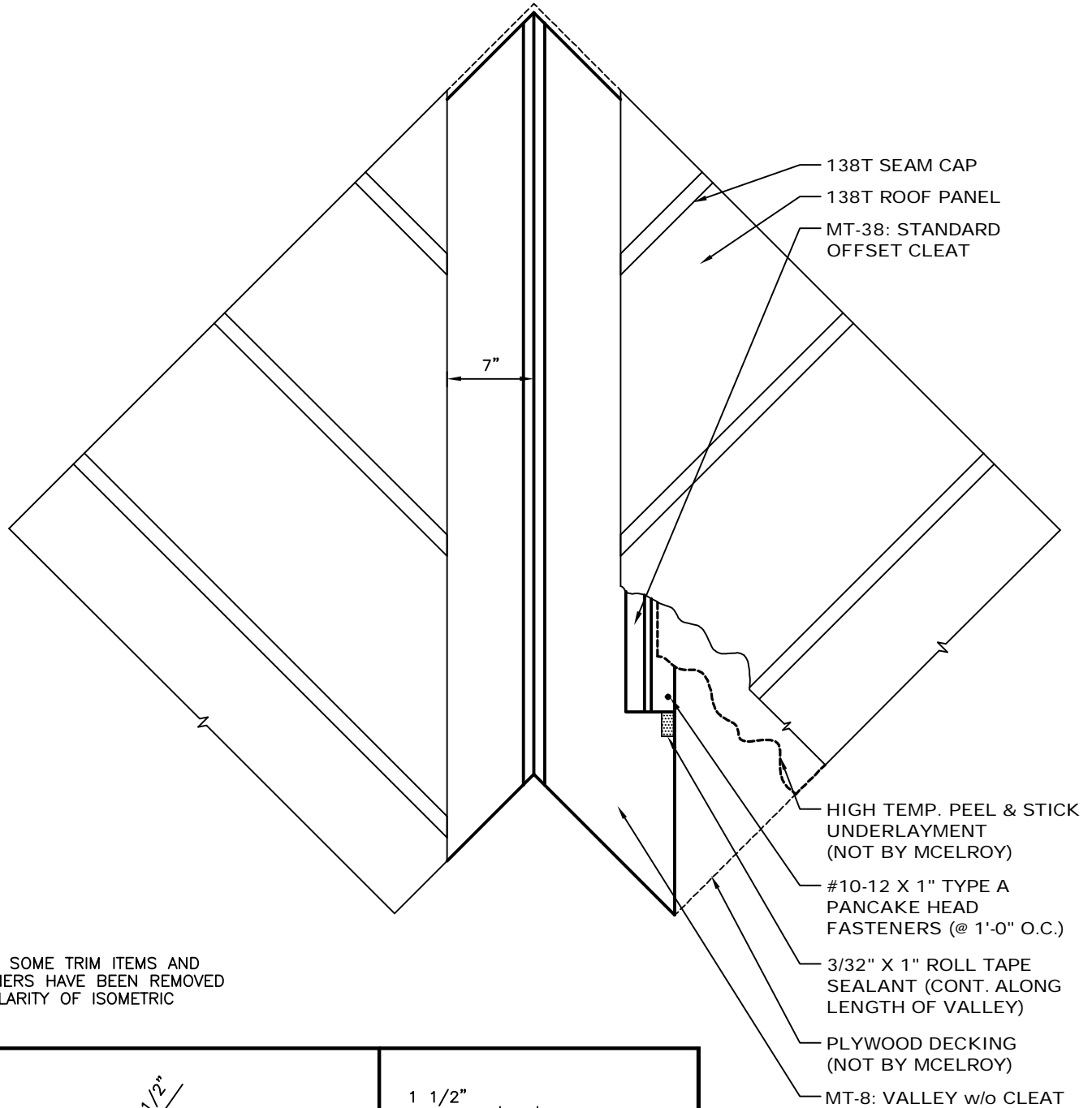

*NOTE: SOME TRIM ITEMS AND FASTENERS HAVE BEEN REMOVED FOR CLARITY OF ISOMETRIC DETAIL.

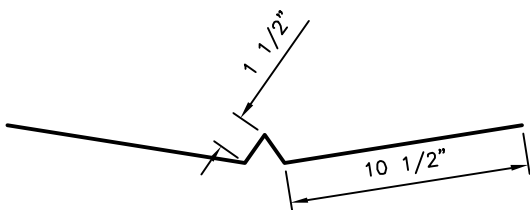

MT-8: VALLEY w/o CLEAT

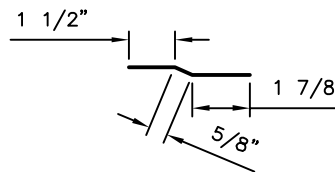

MT-38: STANDARD OFFSET CLEAT

- NOTES: 1. Install MT-8 (Valley w/o Cleat) from eave to ridge. Valley Trim pieces lap 6". Place 3/32" x 1" Butyl Tape or a 3/16" Dia. bead of Butyl Tube Sealant in laps.
 2. Cut panels at required bevel for valley condition.
 3. Apply a continuous line of 3/32" x 1" Roll Tape Sealant up both sides of MT-8 (Valley Trim w/o Cleat).
 4. Attach MT-38 (Standard Offset Cleat) with #10-12 x 1" Type A Pancake Head fasteners at 1'-0" O.C.

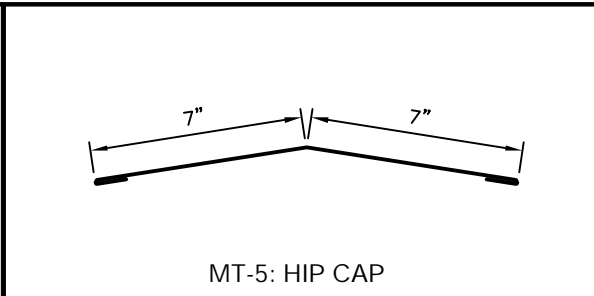
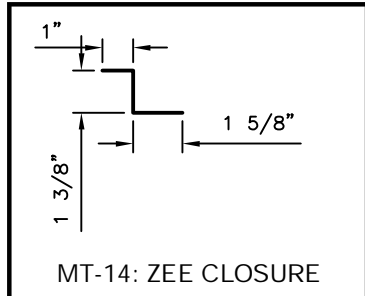
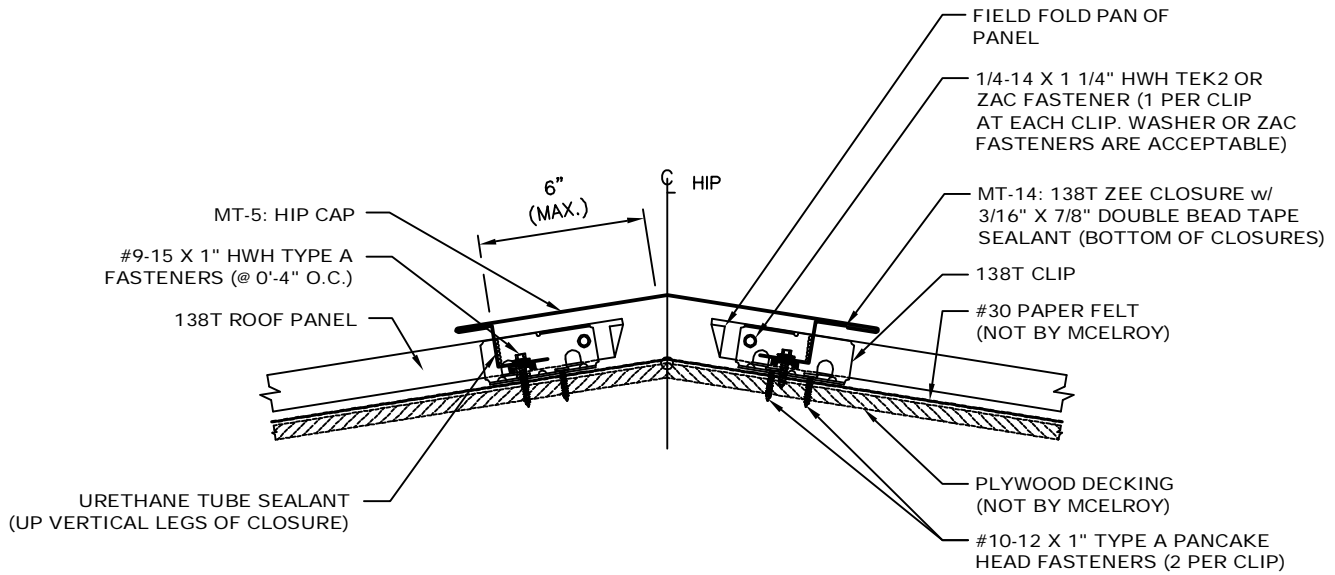

- NOTES:
1. MT-5 (Hip Cap) to run from Eave to Ridge.
 2. Using a panning tool, fold up the pan of the panel at the hip.
 3. Install 138T panels and apply a line of 3/16" x 7/8" Double Bead Sealant in the pan of the panels.
 4. Install MT-14N-16 (Zee Closure) and seal vertical legs of closure and panel with Urethane Tube Sealant. Fix panels to clips with (1) 1/4-14 x 1 1/4" HWH Tek2 or ZAC Fastener, making sure to fasten through the clip.
 5. MT-5 (Hip Cap) laps 2". Apply 3/32" x 1" Butyl Tape and attach to MT-14 (Zee Closure) with Pop Rivets at Laps.

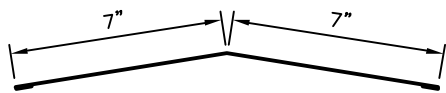
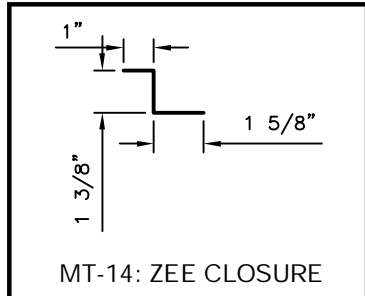
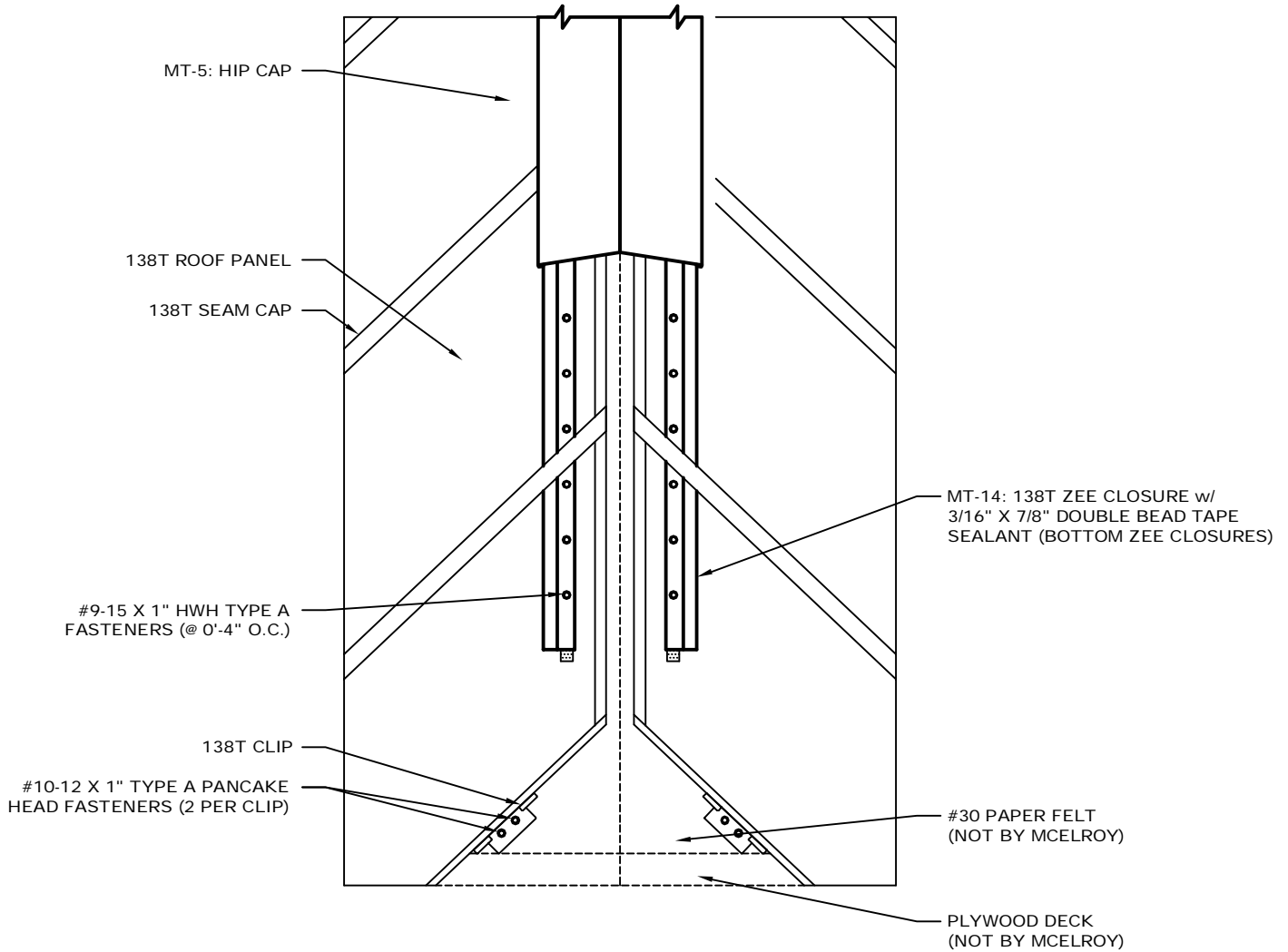

*NOTE: SOME TRIM ITEMS AND FASTENERS HAVE BEEN REMOVED FOR CLARITY OF ISOMETRIC DETAIL.

- NOTES:
1. MT-5 (Hip Cap) to run from Eave to Ridge.
 2. Using a panning tool, fold up the pan of the panel at the hip.
 3. Install 138T panels and apply a line of 3/16" x 7/8" Double Bead Sealant in the pan of the panels.
 4. Install MT-14N-16 (Zee Closure) and seal vertical legs of closure and panel with Urethane Tube Sealant. Fix panels to clips with (1) 1/4-14 x 1 1/4" HWH Tek2 or ZAC Fastener, making sure to fasten through the clip.
 5. MT-5 (Hip Cap) laps 2". Apply 3/32" x 1" Butyl Tape and attach to MT-14 (Zee Closure) with Pop Rivets at Laps.

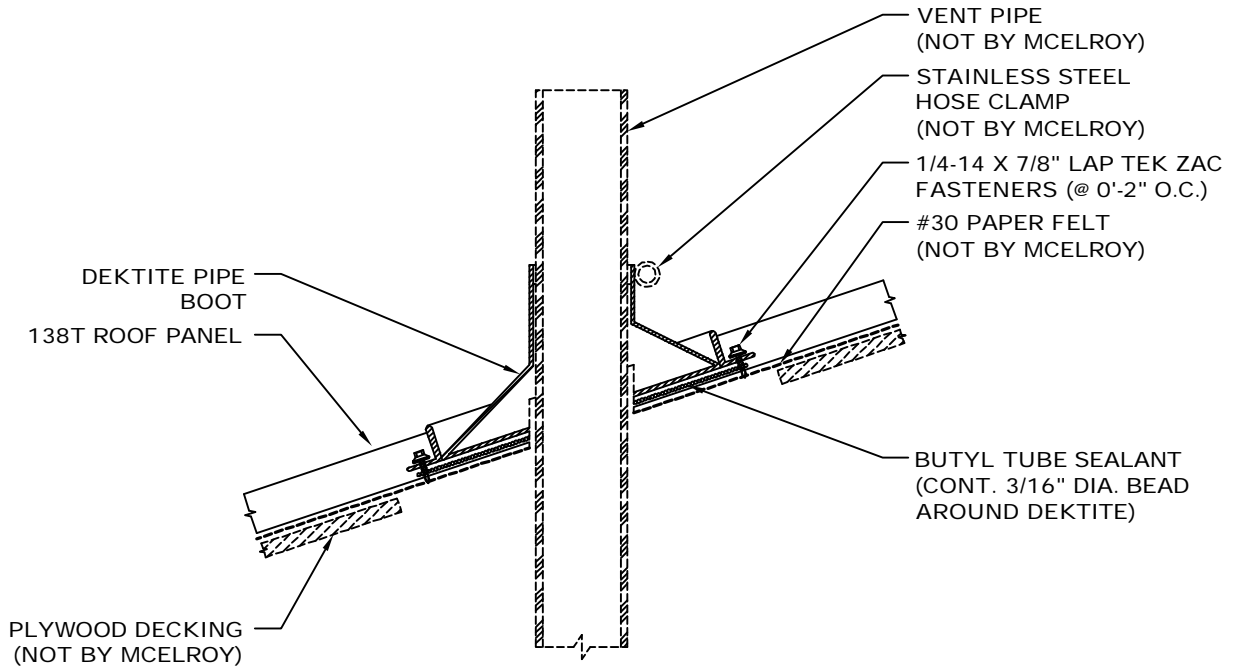

- NOTES: 1. Cut hole in panel 1" larger than pipe diameter. If installing over a solid substrate, over-cut hole in substrate larger than fastener pattern of Dektite so fasteners do not pin system from thermal movement.
2. Cut hole in top of Dektite Boot so that it fits snugly around pipe. Apply a 3/16" Dia. bead of Tube Butyl sealant around the base flange of boot. Secure to panel with 1/4-14 x 7/8" Lap Tek ZAC fasteners 2" O.C.
3. Dektite boot MUST fit in pan of panel. Do not fasten to standing seams.

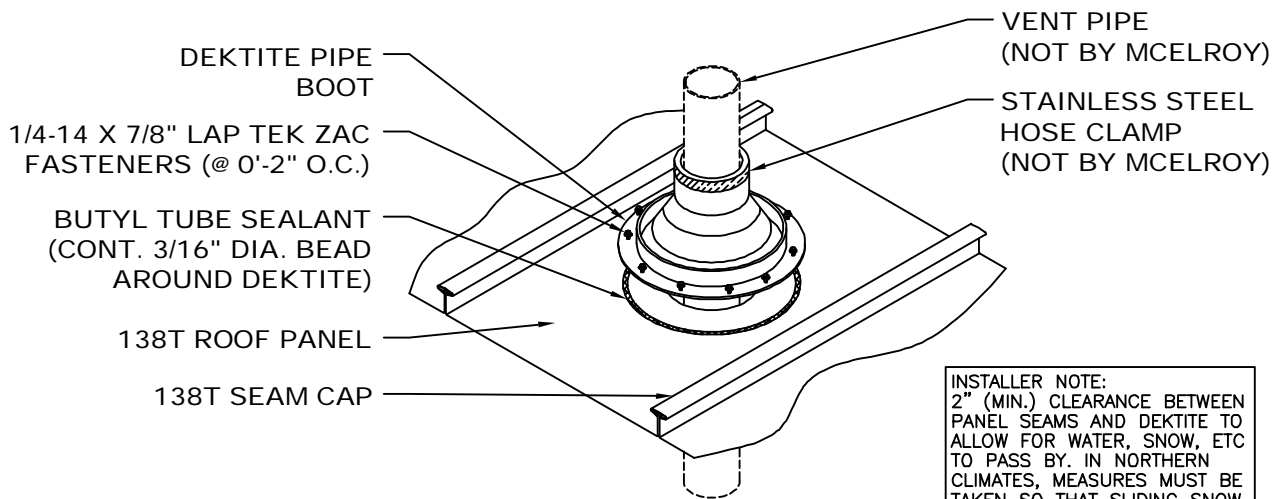

INSTALLER NOTE:
2" (MIN.) CLEARANCE BETWEEN
PANEL SEAMS AND DEKTITE TO
ALLOW FOR WATER, SNOW, ETC
TO PASS BY. IN NORTHERN
CLIMATES, MEASURES MUST BE
TAKEN SO THAT SLIDING SNOW
WILL NOT DAMAGE THE DEKTITE.

*NOTE: SOME TRIM ITEMS AND
FASTENERS HAVE BEEN REMOVED
FOR CLARITY OF ISOMETRIC
DETAIL.

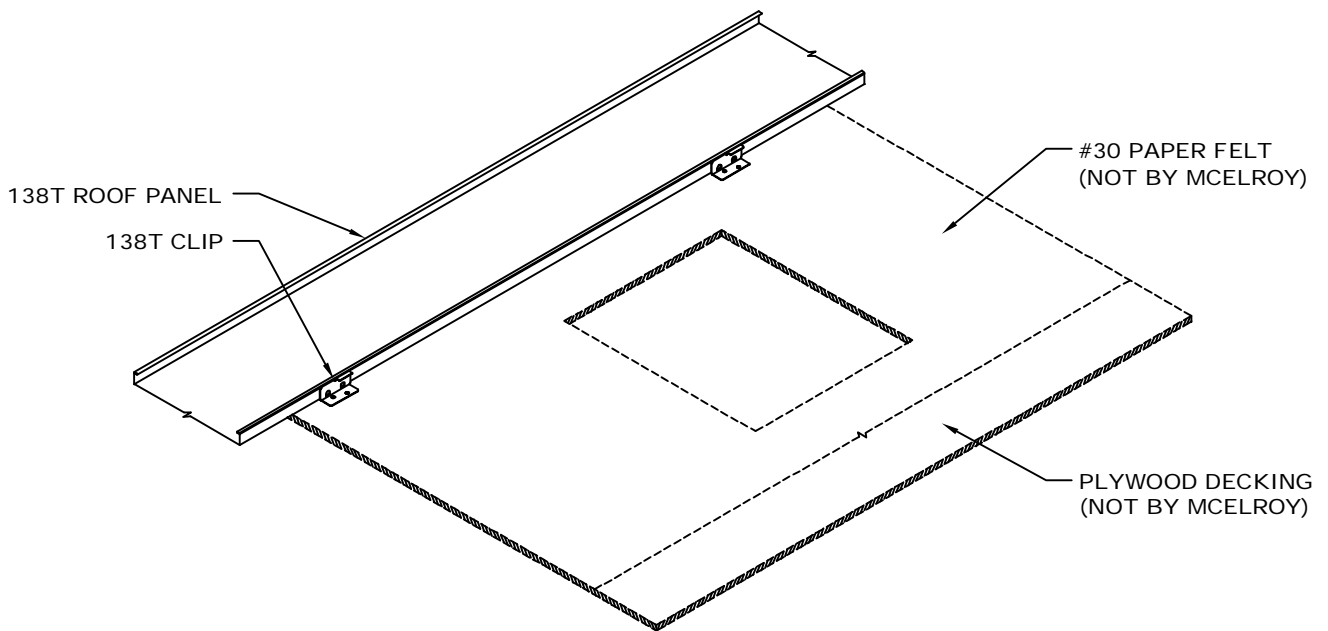

STEP #1

*NOTE: SOME TRIM ITEMS AND FASTENERS HAVE BEEN REMOVED FOR CLARITY OF ISOMETRIC DETAIL.

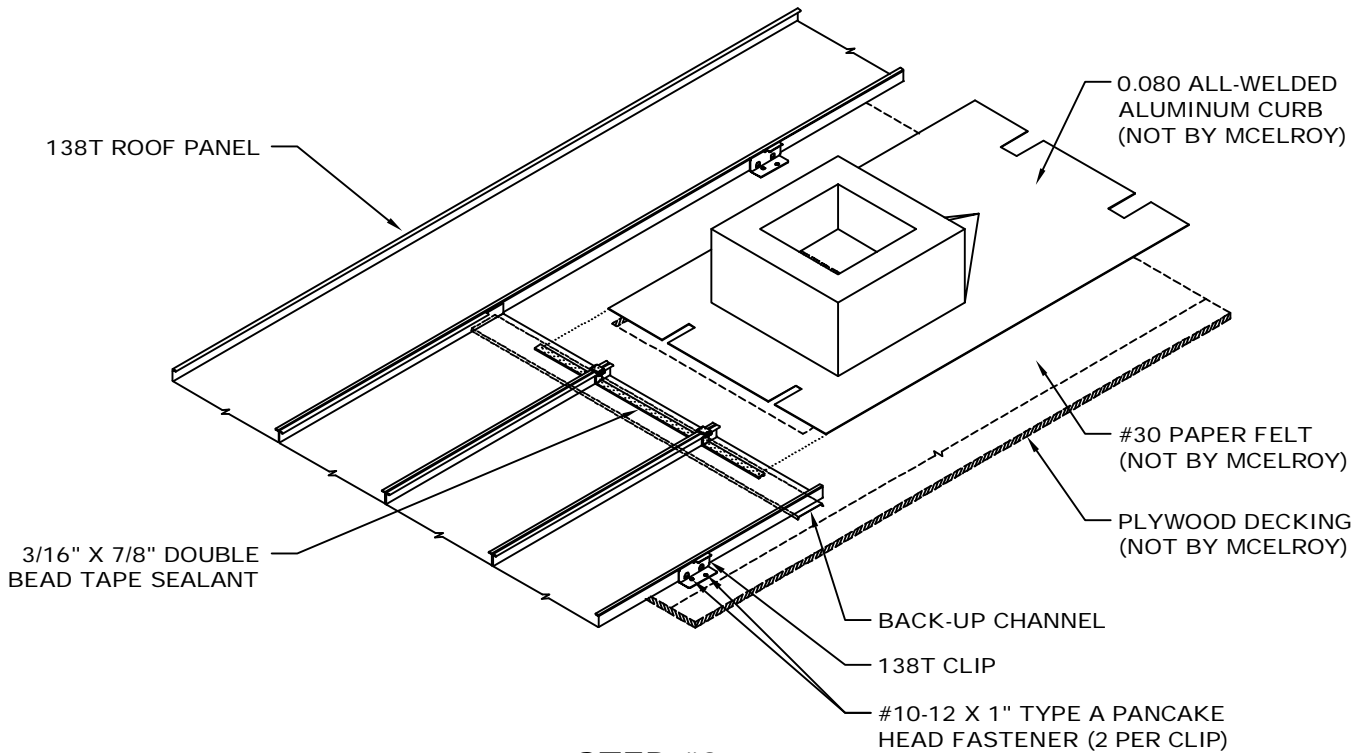

*NOTE: SOME TRIM ITEMS AND FASTENERS HAVE BEEN REMOVED FOR CLARITY OF ISOMETRIC DETAIL.

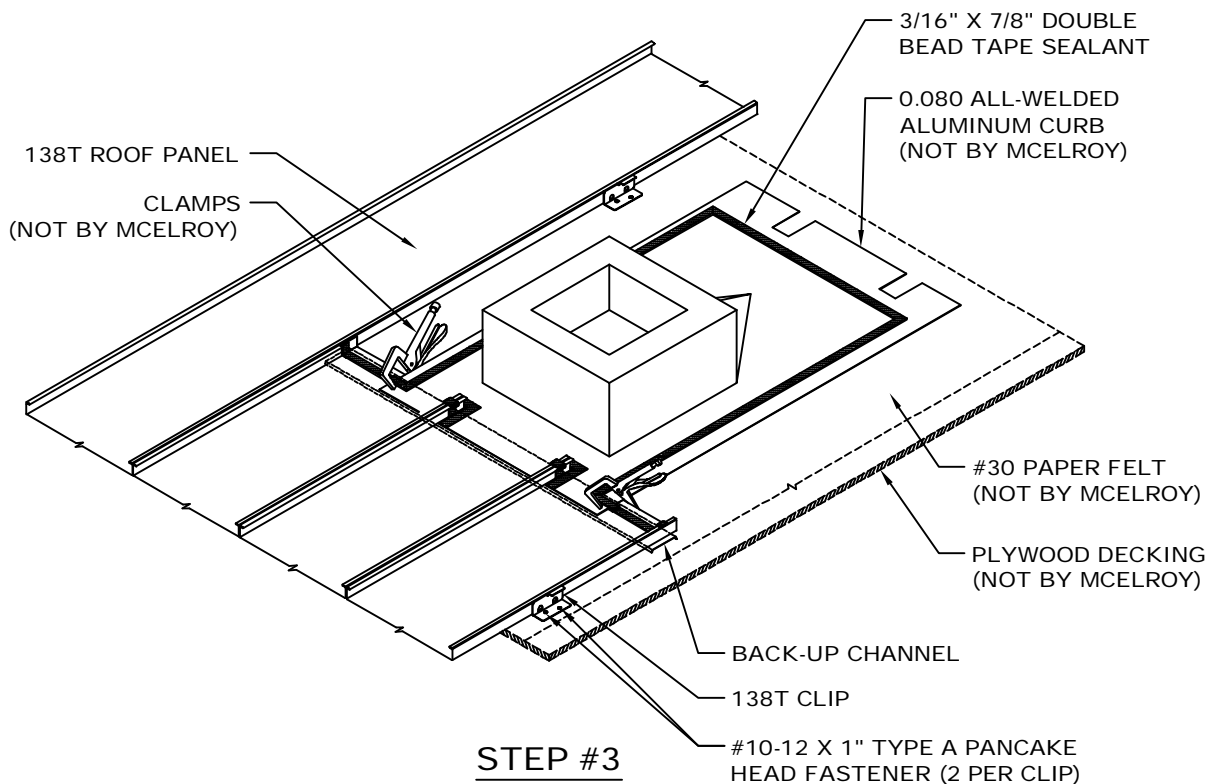

*NOTE: SOME TRIM ITEMS AND
FASTENERS HAVE BEEN REMOVED
FOR CLARITY OF ISOMETRIC
DETAIL.

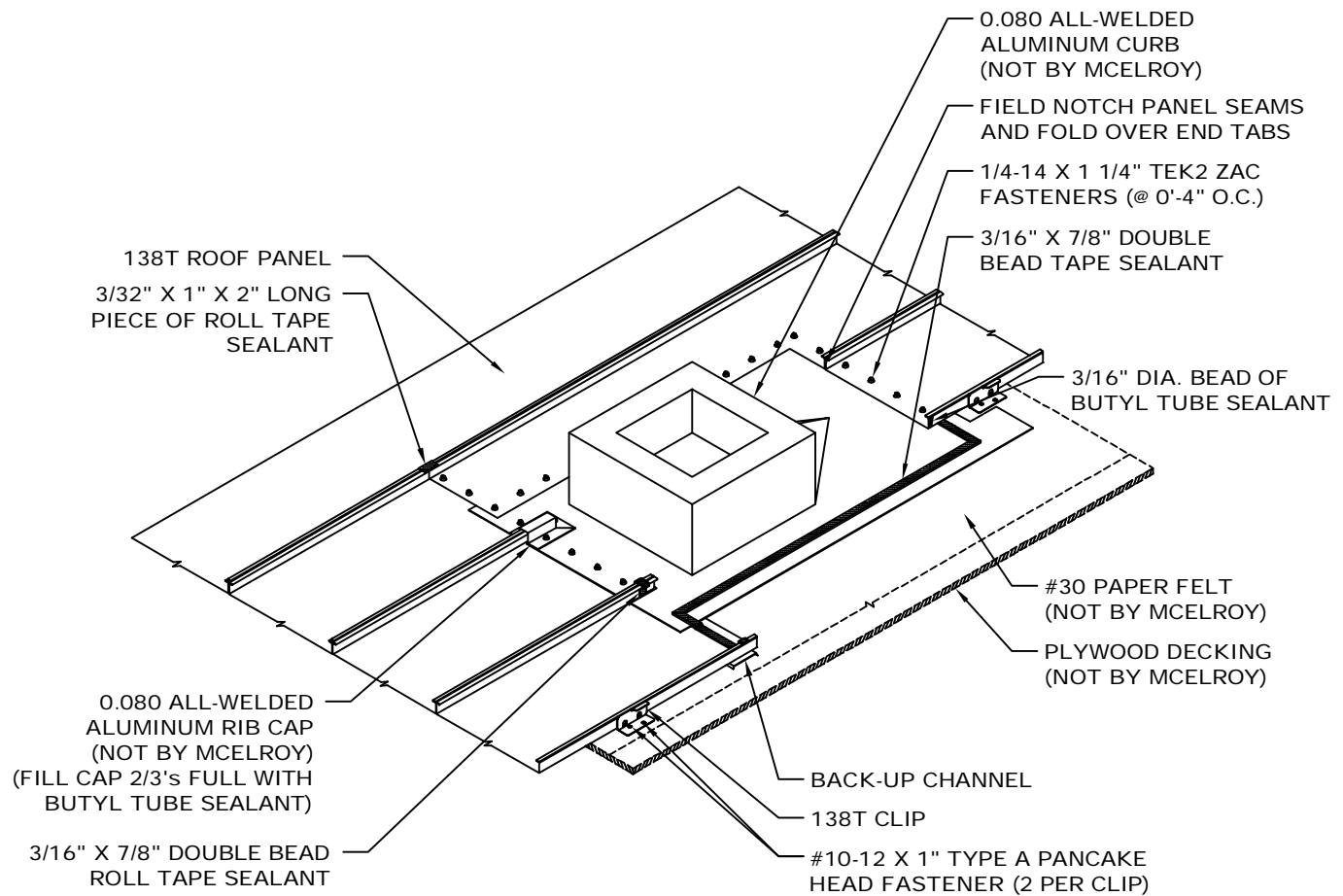

STEP #4

*NOTE: SOME TRIM ITEMS AND
FASTENERS HAVE BEEN REMOVED
FOR CLARITY OF ISOMETRIC
DETAIL.

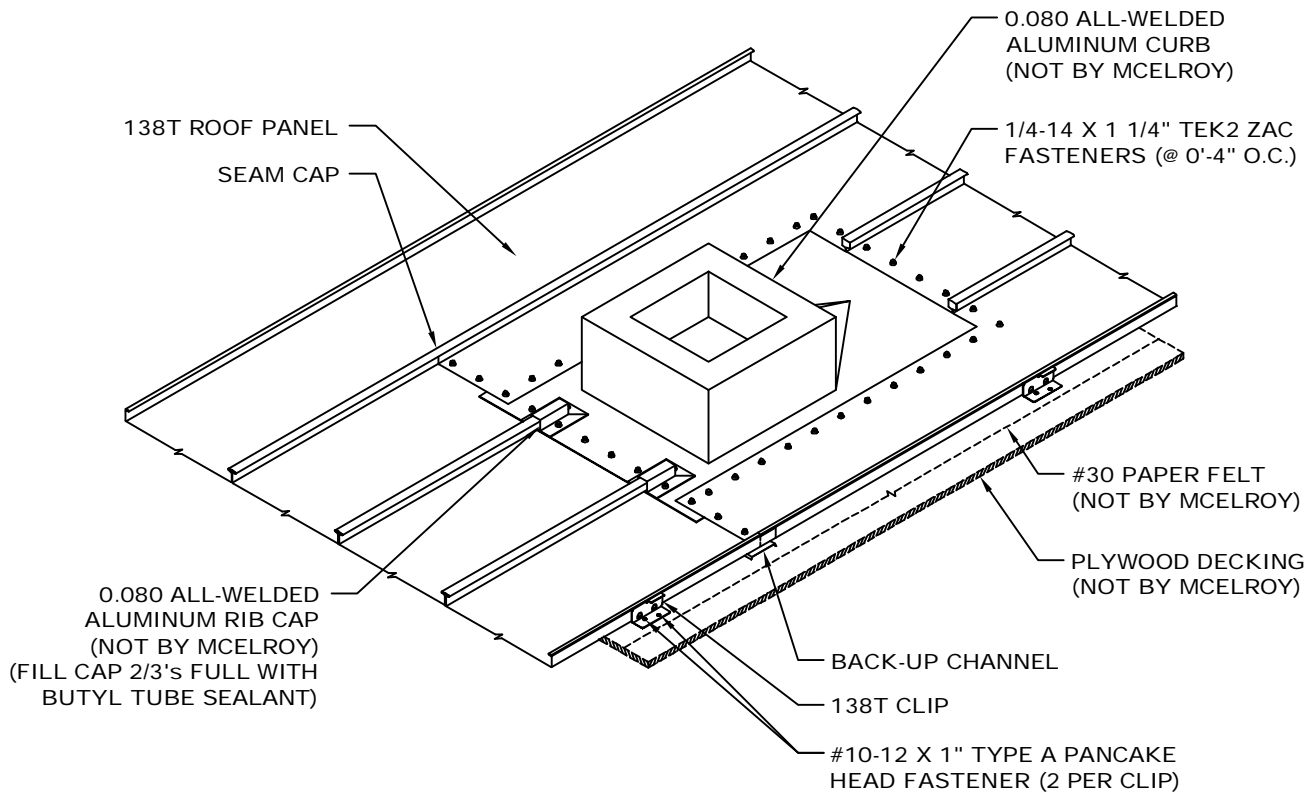

STEP #5

*NOTE: SOME TRIM ITEMS AND FASTENERS HAVE BEEN REMOVED FOR CLARITY OF ISOMETRIC DETAIL.

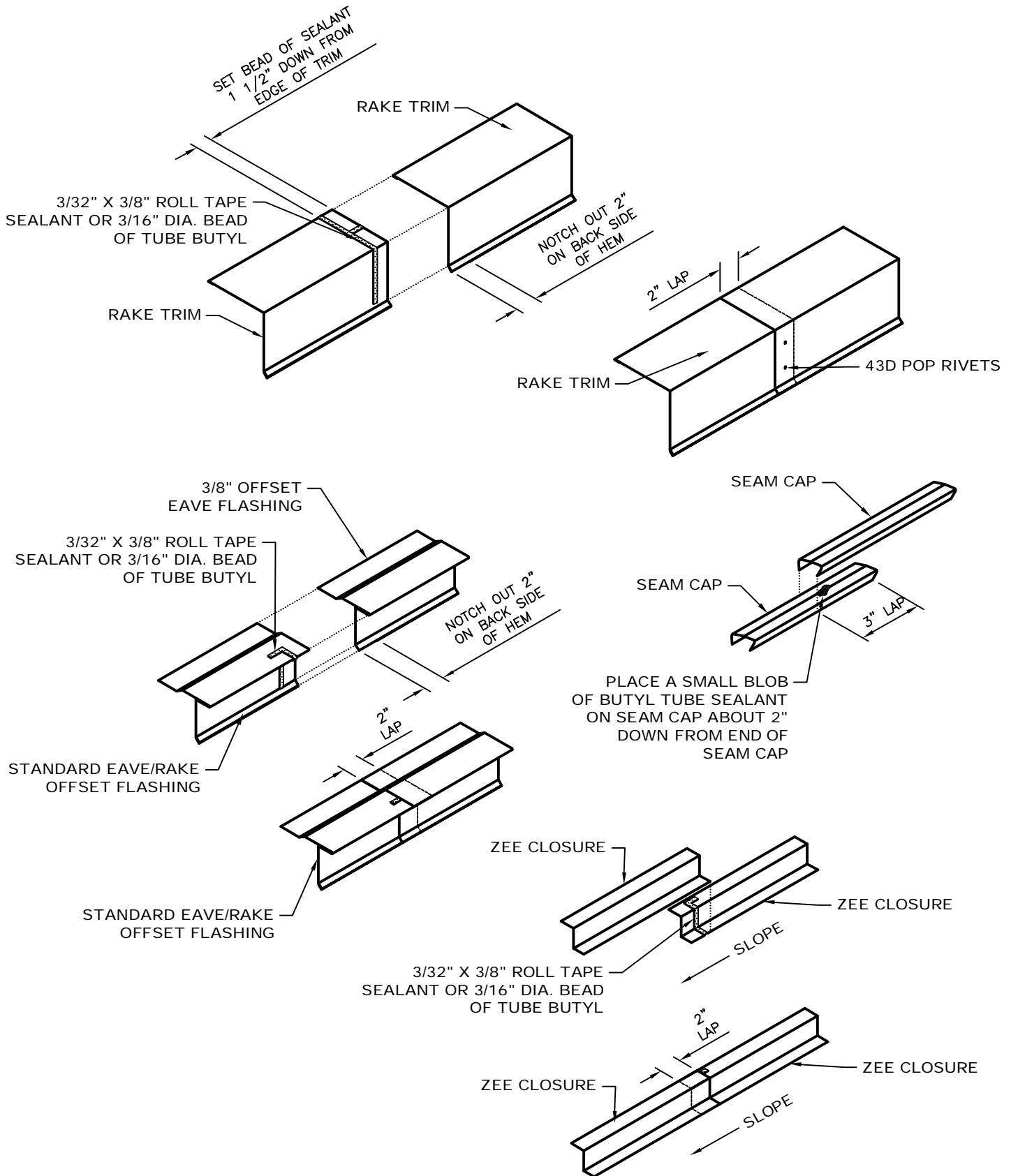

NOTE: 1. Apply 3/32" x 3/8" Roll Tape Sealant or a 3/16" Dia. bead of Tube Butyl 1 1/2" back from the edge of the trim. Also, apply a piece of tape sealant or bead of Tube Butyl as a Pigtail to completely seal joint.
 2. Notch the hems on the upper trim piece 2" so that the trim will fit flat in the lap joint.
 3. Secure trim laps with Pop Rivets as shown above.

TYPICAL TRIM LAP DETAIL

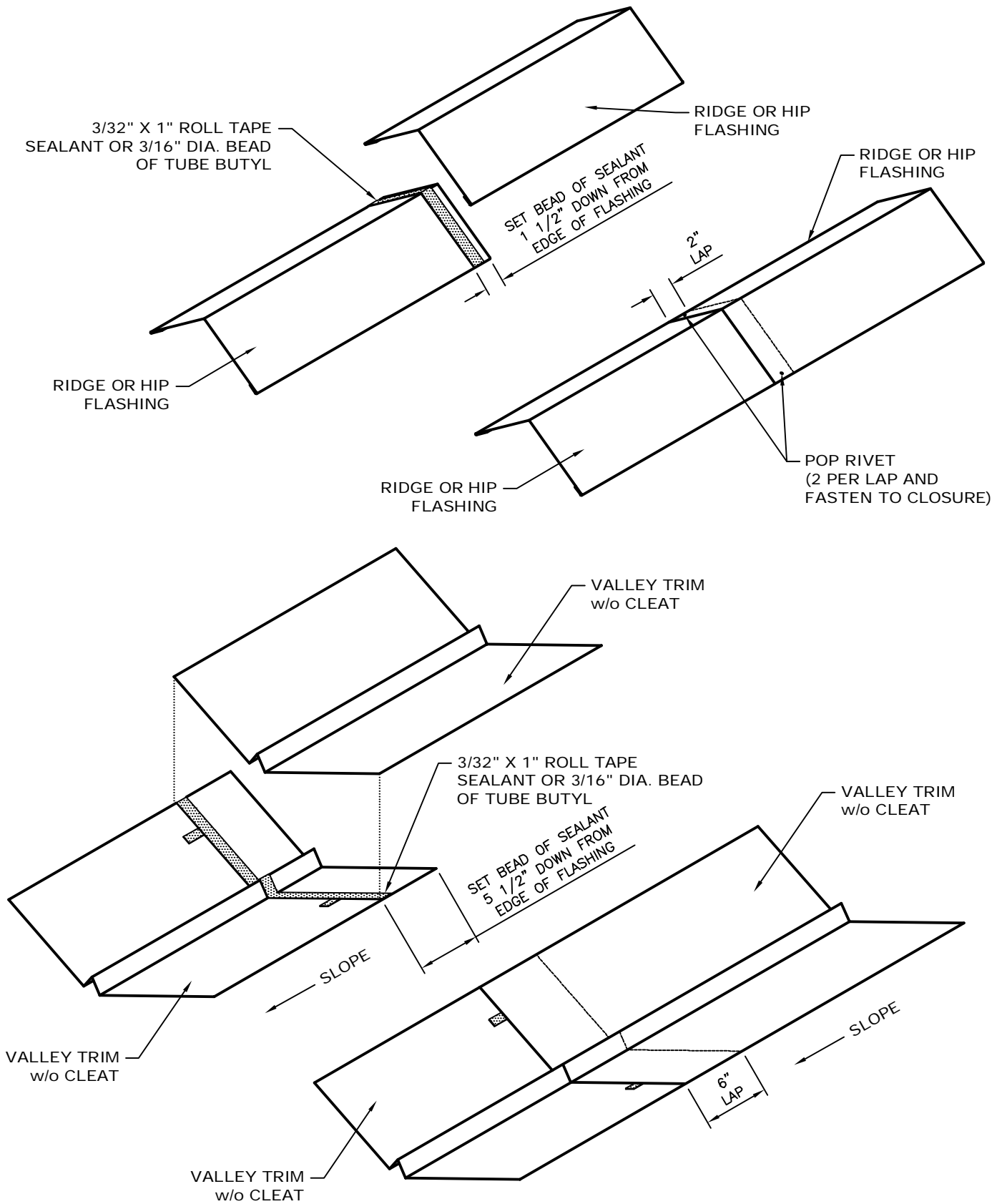

NOTE: 1. Apply 3/32" x 1" Roll Tape Sealant or a 3/16" Dia. bead of Tube Butyl 1 1/2" back from the edge of the trim.
 2. Notch the hems on the upper trim piece 2" so that the trim will fit flat in the lap joint.
 3. Secure trim laps with Pop Rivets as shown above.

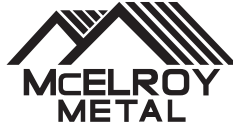

☆ MANUFACTURING LOCATIONS ● SERVICE CENTERS ★ MANUFACTURING AND SERVICE CENTER



CORPORATE OFFICE
1500 HAMILTON RD.
BOSSIER CITY, LA 71111

MANUFACTURING LOCATIONS

ADELANTO, CA	ASHBURN, GA	BOSSIER CITY, LA	CLINTON, IL
HOUSTON, TX	LEWISPORT, KY	MARSHALL, MI	MAUSTON, WI
MERKEL, TX	PEACHTREE CITY, GA	SUNNYVALE, TX	WINCHESTER, VA

McELROY METAL
SERVICE
C E N T E R

5215 Leo St. Alexandria, LA 71301	1007 Wilso Dr, Baltimore, MD 21223	1500 Hamilton Rd. Bossier City, LA 71111	3052 Yadkin Road Chesapeake, VA 23323
9476 Meadowbrook Rd. Clinton, IL 61727	3215 Highway 59 Diamond, MO 64840	390 N. Valley Dell Dr. Fenton, MO 63026	409 Lovejoy Road Ft. Walton Beach, FL 32548
3014 Lincoln Court Garland, TX 75041	1440 Aldine Bender Road Houston, TX 77032	10504 E. 59th Street Indianapolis, IN 46236	9435 US Hwy. 60 W. Lewisport, KY 42351
5123 Terminal Dr. McFarland, WI 53558	514 Cave Road Nashville, TN 37210	8304 Hwy. 70 E. North Little Rock, AR 72117	613 North Bierdeman Rd. Pearl, MS 39208
7450 Tower Street Richland Hills, TX 76118	5300 83rd Street Sacramento, CA 95826	1365 Dean Forest Rd. Savannah, GA 31405	
7355 Oakley Industrial Blvd. Union City, GA 30291	1144 Silstar Rd. West Columbia, SC 29170	325 McGhee Rd. Winchester, VA 22603	

Website: www.mcelroymetal.com • E-mail: info@mcelroymetal.com

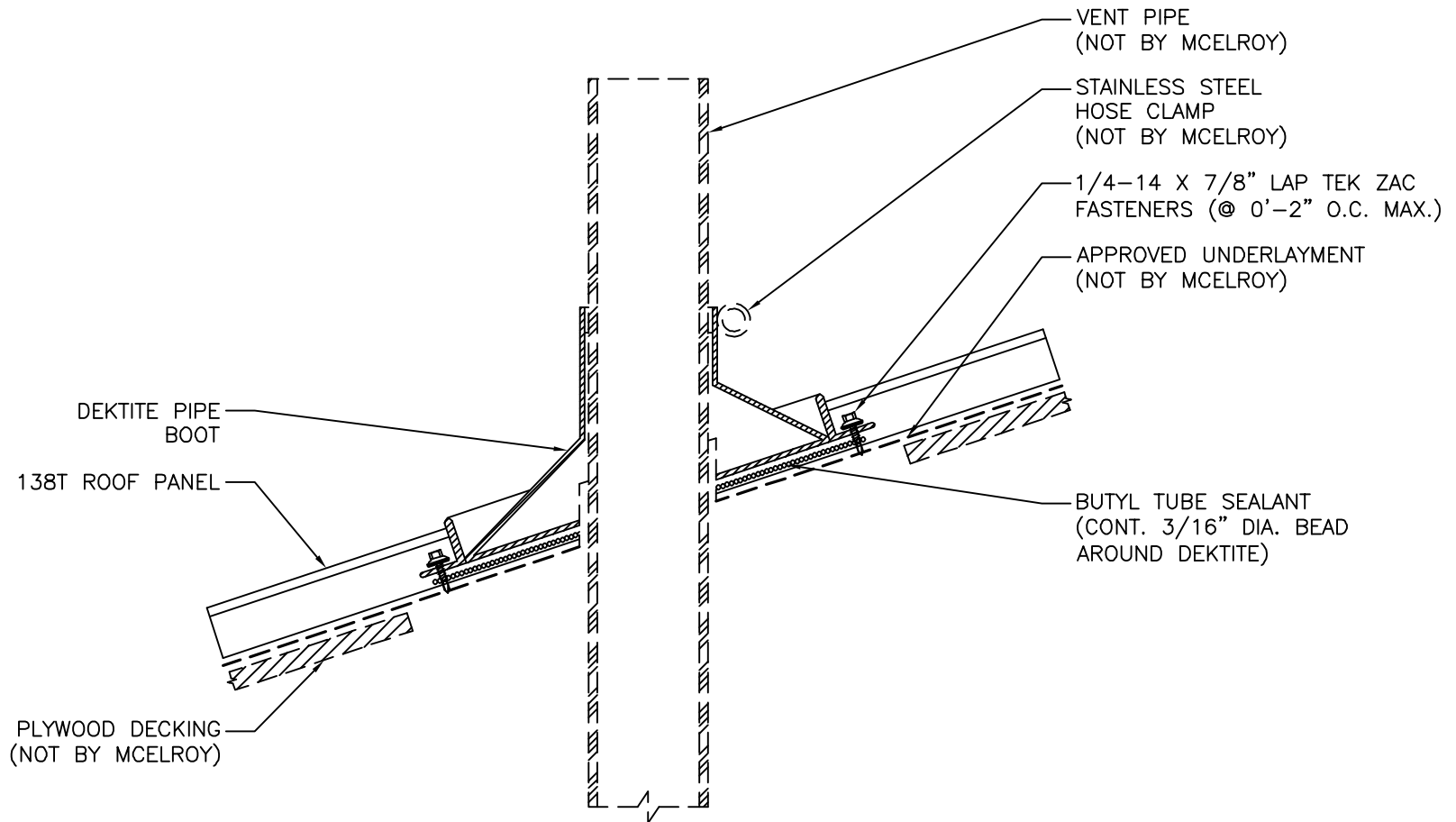

PIPE PENETRATION DETAIL

ISSUE/REVISION DATE:

06/25/2020



ROOF PANEL: 138T

SUBSTRATE: PLYWOOD

SCALE: N.T.S.

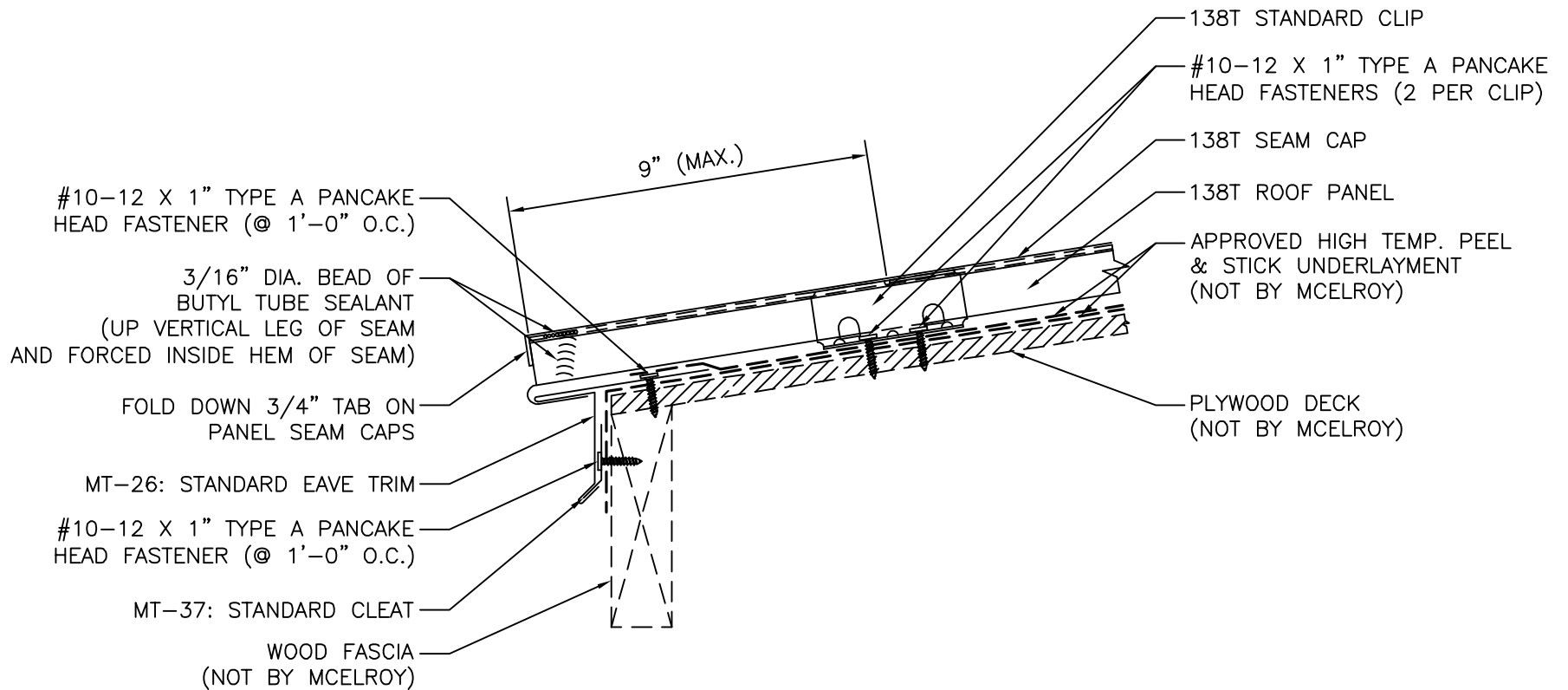

EAVE DRIP DETAIL

ISSUE/REVISION DATE:

06/25/2020

ROOF PANEL: 138T

SUBSTRATE: PLYWOOD

SCALE: N.T.S.

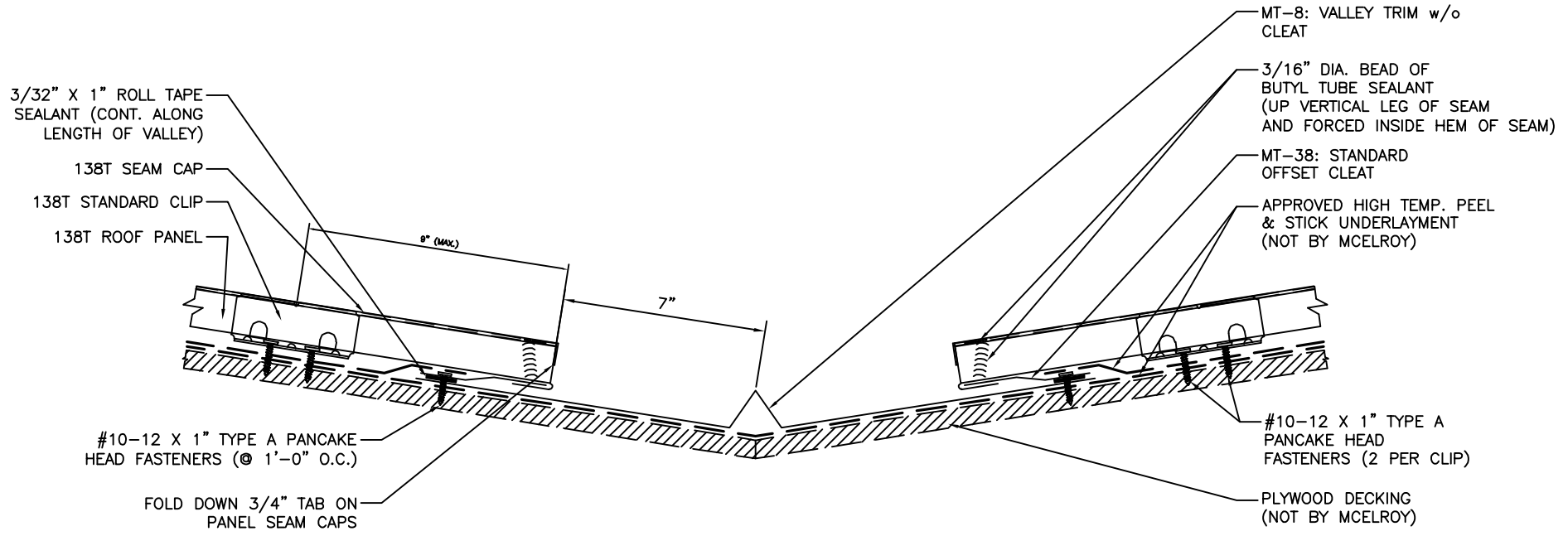

VALLEY DETAIL

ISSUE/REVISION DATE:

06/25/2020

ROOF PANEL: 138T

SUBSTRATE: PLYWOOD

SCALE: N.T.S.

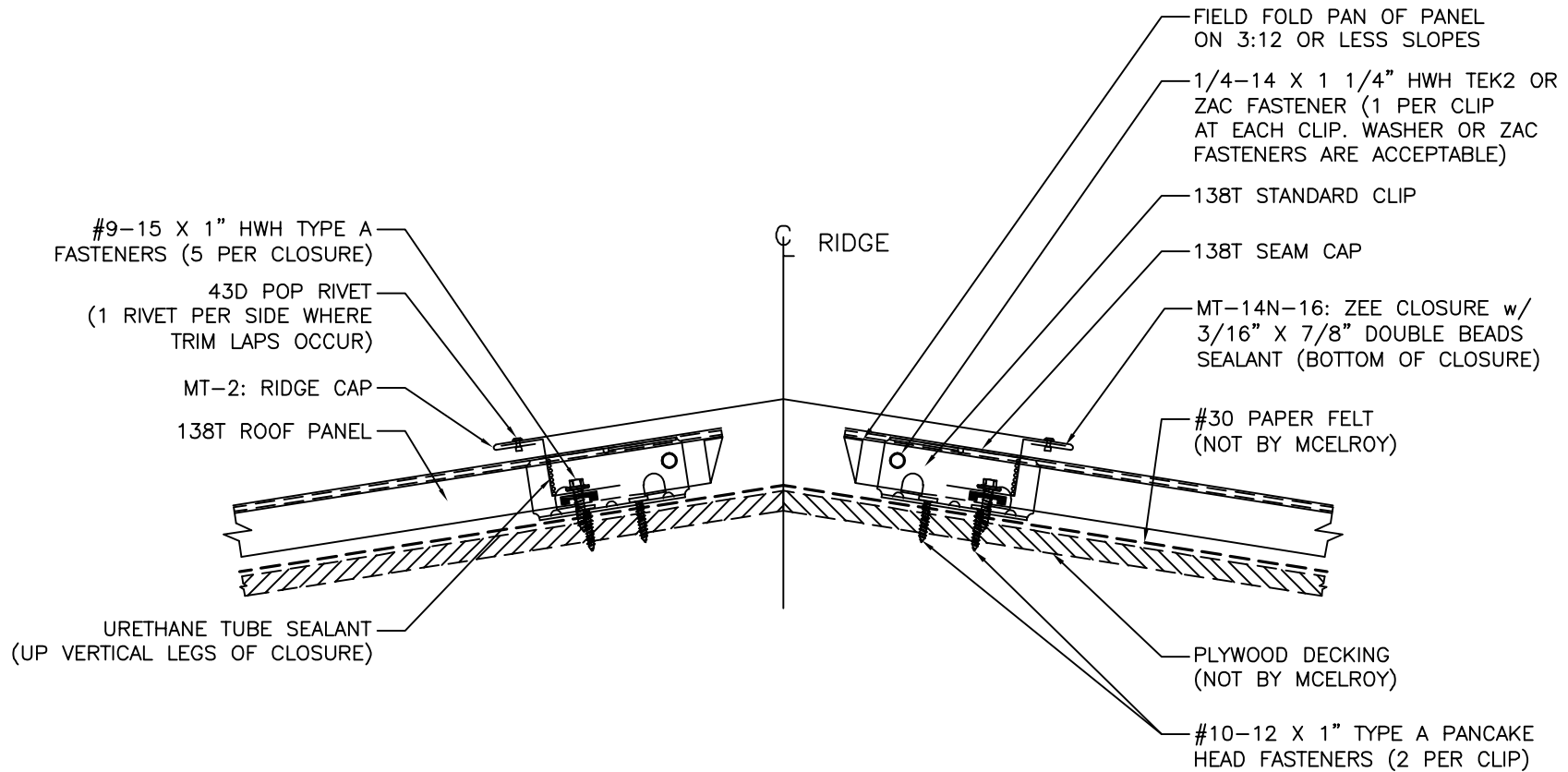

FIXED RIDGE DETAIL

ISSUE/REVISION DATE:

06/25/2020



ROOF PANEL: 138T

SUBSTRATE: PLYWOOD

SCALE: N.T.S.