

---

## Section 8.19 OTK - Old Town Keller

1. *General Purpose and Description.* The OTK District encompasses most of the original town site of Keller. The area generally contains a mixture of some of the oldest buildings in Keller along with newer uses and buildings that have replaced older structures over the years. Vacant lots are scattered throughout the district. The OTK District is designed to transform the area into a historic focal point of the City with the character of a small Texas town of the early to middle 1900's. The standards set forth in this district will ensure design consistency in both the redevelopment of existing structures and in new developments.
  - a. *Boundary Established.* The boundary of the OTK Overlay District consists of Johnson Road on the north, the Union Pacific Railroad on the west, and the actual Bear Creek on the south. The eastern boundary follows various property lines near Elm Street and Ruby Street. Please refer to the attached Old Town Keller boundary map for exact boundaries (See Figure 1 within this Section).
  - b. *Subdistricts Created.*
    - 1) *Main Street Subdistrict.* The Main Street Subdistrict consists of all properties with frontage along Main Street and Keller Parkway. This subdistrict is characterized by continuous storefronts along the streets with deep, long, and narrow shops. Buildings are typically one or two stories in height with flat roofs and display a historic mercantile character.
    - 2) *Neighborhood Subdistrict.* The Neighborhood Subdistrict consists of all other properties within the OTK boundary. A mixture of architectural styles including Minimal Traditionalist with Tudor influence, Bungalow, Craftsman, American Foursquare, and Ranch Style. There are a few examples of the historic mercantile character.
  - c. *Monument Sign Overlay District Created.* The boundary of the Monument Sign Overlay District is the Main Street Subdistrict north of Keller Parkway.
2. *Site Plan Required.* All developments within the OTK District shall be subject to design review as part of the site plan review process. A detailed site plan as outlined in this Code shall be submitted for each use in OTK. Unless specifically noted within this section, all requirements of this Code apply to the OTK District. Design review is required in this district to ensure that development within the district is in conformance with design guidelines for OTK and that proposed development is architecturally compatible and within the historic character of OTK. Site plan approval shall be required for the following:
  - a. All new developments/buildings.
  - b. A change of use in an existing structure.
  - c. Additions to existing non-residential buildings or additions to residential buildings costing twenty-five percent (25%) or more of appraised value as determined by the Tarrant Appraisal District.
  - d. Remodeling of existing non-residential buildings costing twenty-five percent (25%) or more of appraised value as determined by the Tarrant Appraisal District.
3. *Development Standards - Main Street Subdistrict of Old Town Keller.*
  - a. *Site Orientation and Layout.* The front facades of buildings or dining patio fencing in new developments or proposed remodeling shall be located close to the sidewalks to encourage pedestrian involvement and to provide an area for landscaping, benches, tables and other types of street furniture. Parking shall be provided at the rear of developments (see Figure 2 within this Section). Developers shall share in the cost of remote parking lots if parking cannot be provided on site.
  - b. *Size of Lot.*

- 
- 1) Minimum lot area: Two-thousand five-hundred (2,500) square feet. (Amended by Ord. No. 1805 on August 16, 2016)
  - 2) Minimum lot width: Twenty-five feet (25'). (Amended by Ord. No. 1805 on August 16, 2016)
  - 3) Minimum lot depth: Sixty feet (60'). (Amended by Ord. No. 1805 on August 16, 2016)
  - 4) Lot and tracks in existence prior to July 7, 2015 shall be deemed conforming and may be developed or redeveloped in compliance with all other sections of this Code, provided their dimension are unchanged except for dedications of Rights-of- Way. (Amended by Ord. No. 1805 on August 16, 2016)
- c. *Size of Yards.*
- 1) **Minimum front yard:** The character of Old Town calls for 'Build-to' lines, reducing the setback from the street as much as possible while still accommodating the landscape buffer, sidewalk and necessary easements. This is typically fifteen feet (15'), however may vary from case-to-case to achieve the build-to scenario.
  - 2) **Minimum side yard:** Fifteen feet (15') adjacent to a street.
  - 3) **Interior side yard:** No side yard is required provided that:
    - a) Both property owners agree to adjoin buildings.
    - b) Adequate fire lanes and circulation is provided on site. c) Appropriate building codes can be met.
  - 4) **Minimum rear yard:** Five feet (5').
- d. *Building Height.* Maximum building height shall be two (2) stories or thirty-five feet (35'). Buildings may be up to four (4) stories if approved by the City Council at the time of site plan review. Building height shall be measured from the ground to the peak of the roof. New construction shall have a minimum height of twenty feet (20') to maintain a well- defined street space.
4. *Outside Storage and Outside Display.*
- a. The provisions for outside storage and display shall apply to all permitted uses in accordance with this Code within the Old Town Keller District (OTK).
  - b. Outside storage and display are prohibited on vacant or undeveloped lots.
  - c. All outside storage and display areas shall not be located in or on any required parking spaces, sidewalks, public rights-of-way, or required landscape or buffer areas.
  - d. A minimum accessible pathway in areas used for outside storage or display shall be provided to allow for flow of pedestrian traffic outside of designated vehicular traffic drives.
  - e. All outside storage and display areas shall be maintained free of garbage and other debris.
  - f. Outside storage and display areas for single-occupant or multi-occupant structures or buildings shall be limited to ten percent (10%) of the total gross floor area of the structure or building with a maximum storage and display area of one thousand five hundred (1,500) square feet.
  - g. Merchandise must be freestanding and not be located in or on pallets, crates, stands, shelving, racks, or similar types of storage structures.
  - h. Only goods and merchandise associated with the existing on-site business use may be sold or displayed on-premise.

- 
- i. Outside storage and display areas of bulk goods and merchandise including, but not limited to mulch (bag or bulk), concrete, salt, tires, or other similar products that cannot be easily carried into the store for purchase shall meet the following requirements:
    - 1) Outside storage and display areas are located in the side or rear yards.
    - 2) Outside storage and display areas, goods, and merchandise shall not exceed the height of six feet (6').
    - 3) Outside storage and display areas shall be screened from view of the public rights-of-way and adjacent residential properties by an opaque fence of suitable height to prevent visibility from public rights-of-way.
    - 4) Where screening or fencing is provided or required, decorative iron with landscaping, aluminum with landscaping, wood, or materials being used on the primary structure or building shall be used for fencing. Other materials may be considered with the administrative approval of the Planning Manager.
    - 5) Screening shall not be required if the outside storage and display area is located out of view from any public rights-of-way.

**5. Design Standards - Main Street Subdistrict of Old Town Keller.**

a. *Architectural Requirements.*

- 1) *Materials.* The selected architectural materials must reflect a sense of quality, history, and permanence by utilizing brick, stone, stucco, fibrous cement and concrete. The use of split-faced concrete block shall be limited to the base of a building up to three feet (3') in height from the foundation. Metal and canvas are acceptable materials for awnings and canopies. Vinyl or plastic awnings or canopies shall not be allowed. The color of building materials and the facade shall reflect the eclectic character of the early to mid 1900's, and include earth tones of red, tan, brown and off-white. Accessory structures shall compliment the main structure in façade and design.
- 2) *Facade composition pattern of openings and surface features, a recognizable entry, an interesting roofline, and appropriate building materials.* Aspects of the architecture and eclectic character of the Main Street subdistrict, reminiscent of early to middle 1900s, such as materials, colors, window types, cornices, and overall proportions should be reflected in the overall facade composition. Blank walls are prohibited on the front facade and on any facades that may face side streets. As much storefront glass as possible must be incorporated into the facade along with projecting elements and recesses in the facade to define individual tenants within the building. Materials and architectural elements of the front facade shall be carried on all sides of the building (see Figure 3 within this Section).
- 3) *Building entrances.* Building entrances must be prominent and easy to identify. The main building entrance must be distinguishable along the storefront. At least one of the following treatments is required:
  - a) Entrance located in the center of the facade, as part of a symmetrical overall composition;
  - b) Entrance accented by architectural elements, such as columns, overhanging roofs, awnings, or balconies;
  - c) Entrance marked or accented by a change in the roofline or change in the roof type.

If rear or side entries are provided, they must be prominent and easy to identify and should be treated as a secondary main entrance in a manner similar to the main entry. Buildings adjacent to the promenade must provide a primary access to the promenade.

- 
- 4) *Accent elements.* Accent elements such as cut-out openings and latticework, balconies, ornamental building numbers, medallions, and decorative ceramic tile accents must be incorporated into the design of the building to reflect the eclectic character of the Main Street subdistrict, reminiscent of the early to middle 1900s.
  - 5) *Mechanical equipment.* Exterior building walls shall be tall enough to shield all rooftop mechanical equipment from the streetview. Other screening devices such as latticework, louvered panels, any treatments that are compatible with the building's architecture may be considered on a case-by-case basis with approval by the City Council. All ground-mounted mechanical equipment shall be screened within an opaque material matching the building style, durability and color.
  - 6) *Residential-style architecture.* Any buildings, in the form of new construction or being relocated from another location and having a residential-style architecture fitting the character of the district, may be considered in the Main Street subdistrict on a case-by-case basis and approved by the City Council as an element of a site plan application.
- b. *Landscaping, Lighting, Street Furniture, Fencing, and Sidewalk Requirements.*
- 1) *Street Trees.* Large canopy trees shall be planted along Main Street in a straight line spaced at a distance allowing for healthy mature tree canopy between the sidewalk and the street in areas where possible. Understory street trees may be proposed in place of large canopy trees if overhead power lines are present. Such proposals shall be considered by the Planning Manager or his/her designee for final determination. Tree grates shall be provided for tree planting in paved areas. Open tree grates shall be at least five feet by five feet (5' x 5') with openings no more than one-fourth inch ( $\frac{1}{4}$ " ) in width (in narrow sidewalk areas, three-foot by seven-foot (3' x 7') is an acceptable alternate). The size and shape of the tree grates must relate to the paving pattern. The grates must be designed to allow for tree trunk growth and be constructed of ductile iron with a durable factory applied finish. Landscape up-lighting and electrical outlets shall be provided in the tree grate area. All trees and landscaping must be provided with adequate and inconspicuous irrigation systems.
  - 2) *Courtyards and Small spaces.* Scale appropriate landscaping shall be designed and planted in courtyards and in areas where space is limited near existing buildings. All new developments shall have foundation watering to reduce soils shifting and appropriately scaled plantings in front of the building and along any sides adjacent to public streets. The foundation planting area shall be a minimum of five feet (5') in width and contain a mixture of landscaping to provide seasonal interest and color.
  - 3) *Existing Building Surrounded by Paving.* In lieu of foundation planting, landscaping may be provided in raised planters, pots or raised landscape beds in the front and sides of existing buildings that are surrounded by paving or to provide for an outdoor patio. The container landscaping chosen must provide near equivalent coverage as a five foot (5') foundation landscape bed. An automatic irrigation system must be provided to ensure adequate hydration of the selected landscaping.
  - 4) *Streetlights and Street Furniture.* Decorative style streetlights, benches and trash receptacles of a style and color similar to those currently in place and provided in Figure 6. Street lights shall be installed on all street corners and at a spacing between street corners not to exceed sixty feet (60') in a uniform manner as each property is developed or redeveloped.
  - 5) *Lighting.* Light for off-street parking facilities shall be of the same height, style and color of the required streetlights mentioned above. Lighting fixtures attached to buildings shall be of a decorative or historic character that is compatible with the architecture of the buildings and the required streetlights.

- 
- 6) *Fencing and Screening.* Masonry products in keeping with the OTK common area style must be used to screen dumpsters. In areas where fencing is appropriate, as determined by the DRC, materials and styles fitting the character of the neighborhood shall be used. If wood fencing is proposed, details including construction, footing design, specific materials proposed, and maintenance to maximize life must be included in the site plan and permit request.
- c. *Sidewalk Patios.*
- 1) *Sidewalk Patios.* Sidewalk patios are encouraged along the promenade. The design of the interior and immediate surroundings of a sidewalk patio should adhere to the following guidelines.
- a) The clear height from grade level to any obstruction such as an overhead canopy should be a minimum of seven feet (7').
  - b) The surface area of an outdoor patio may not exceed the interior floor area of the primary licensed establishment.
  - c) The path to the door of the primary licensed establishment shall be maintained at three feet (3').
  - d) The patio shall extend to the building line when located between the primary licensed establishment and the street.
- 2) *Patio Fencing.* Fences or railings are used to delineate and contain the patio.
- a) A fence or other vertical barrier must be used to delineate the perimeter of the patio area.
  - b) The width of any opening in a fence should be no greater than six and a half feet (6.5') and no less than three feet (3').
  - c) The required height of a fence facing the street is three and a half feet (3.5'). Side screens may be up to seven feet (7') high above the grade. Such screens should not be entirely opaque but may be formed by structures with lattice or grillwork and climbing vines.
  - d) Fences and screens should be easily removable at all times.
  - e) The design, materials and colors used in the development of the patio restaurant should be of high quality finish and compatible with the streetscape.
  - f) All finishes should be clean and free of any exposed screws or other fasteners. g) Perimeter fences shall not obstruct the line of sight for pedestrians and drivers.
- 3) *Awning.* Awnings can be used to provide shade and weather protection for the patio as well as visual screening from adjacent uses.
- a) Materials should be securely fastened to a frame, which is either retractable or demountable.
  - b) Sheltering material should be fabricated and finished to fit the supporting structure with no loose or unsecured edges.
  - c) Materials and colors should coordinate with the surrounding buildings and streetscape elements. They should generally contribute to the design theme of the street.
  - d) The awning should not extend into the public sidewalk adjacent to the patio.
  - e) The awning should attach to the building below the signage identifying the restaurant with a minimum height of seven feet (7').
  - f) Lighting and other attachments to the awning should be securely fixed and integrated to the supporting structure.

- 
- g) A building permit is required for awnings.
  - h) Awnings shall be maintained in excellent condition at all times.
- 4) *Enclosures.* Enclosures may be used for more extensive weather protection and to extend the patio season.
- a) Enclosures must include a minimum of one continuous opening (from ground to canopy) to the outside (ie. no roll-down walls of any kind, however slide up/down doors are acceptable)) that comprises at least 25% of the total perimeter of all of the patio walls.
  - b) The enclosure area should be well ventilated to provide for dispersion of smoke and exchange of air.
  - c) Ventilation should be directly to the exterior and may be achieved by passive means through vents in the awning and/or active fans.
  - d) Cash machines should not be located within the patio area, except where enclosed within a freestanding building or kiosk.
  - e) A building permit is required for the construction of an enclosure.
- 5) *Lighting.* Lighting is important to the function and appearance of a patio as well as the safety and security of the public environment.
- a) Exterior lighting should not spill into abutting private property or interfere with the public thoroughfare.
  - b) Lighting should be demountable with no exposed cables or energized fixtures. c) Lighting design should coordinate with patio furnishings and streetscape design.
  - d) Lighting should not be attached to trees or shrubs on City property; however string lighting to highlight deciduous trees within the patio area is permitted.
  - e) Lighting should be used to identify the entrance to a patio.
  - f) Pathways through a patio should be illuminated to ensure the safety of patrons and staff.
- 6) *Plant Materials.* Plant materials contribute to our general comfort and enjoyment of the patio experience.
- a) Planting of annuals, vines and container-grown vegetation is encouraged but should be easily removable from the site.
  - b) Planters should be integral with fence and deck structures to maintain a compatible design relationship.
  - c) Deciduous shade trees enhance the quality of the patio space with shade and screening.
  - d) Planting should be used along with spatial separation and structures to screen a patio from adjacent vehicle parking and circulation.
  - e) Planters must not obstruct the public right of way.
- 7) *Surface Treatment.* The paving of a patio surface provides durable and attractive platform for the patio, which is distinct from the public right-of-way.
- a) Paving should be durable, skid-proof and easily maintained in a clean and unobstructed condition.
  - b) The minimum slope of pavement should be 1% and the maximum slope 4% within the seating area.

- 
- c) A change in elevation may be used to define the edge of a patio, but should not create an additional barrier to movement.
  - d. *Sidewalks.* All sidewalks along Main Street in the Main Street Subdistrict shall be constructed of brick pavers in the same design, pattern and color as the sidewalk in place along South Main Street between Taylor Street and the Big Bear Creek Bridge. Properties with existing concrete sidewalks shall upgrade the sidewalk with brick pavers in the manner described above when any building additions are proposed or when remodeling existing buildings at a cost of twenty-five percent (25%) or more of the appraised value as determined by the Tarrant Appraisal District.
  - e. *Signage Requirements.* All signage for new buildings/uses or change in use shall comply with these requirements at the time of sign permit.
    - 1) A sign permit shall be required for all signage.
    - 2) Signage may be internally or externally illuminated.
    - 3) Unless located in the OTK Monument Sign Overlay District, monument signs are not permitted in OTK. Within the OTK Monument Sign Overlay District, only one (1) monument (see 8.09) or detached sign (i.e. post and bracket) shall be allowed per business per public street frontage.
    - 4) Only one (1) attached sign shall be allowed per building or lease space elevation exclusive of address number signs and shingle signs. (Amended by Ord. No. 1799 on July 5, 2016)
    - 5) Sign sizing shall be as set forth in Section 9.05. (Amended by Ord. No. 1799 on July 5, 2016)
      - a) Wall mounted signs on Main Street must be historic in context with the eclectic character of the Main Street Subdistrict.
      - b) Projecting signs are considered attached wall mounted signs and shall be allowed provided that they do not extend more than four feet (4') from the wall surface. (See Figure 4 within this Section). Vertically oriented (projection sign) signage shall be placed a minimum of ten feet (10') above grade.
      - c) Shingle signs on Main Street may be up to four (4) square feet and in keeping with the eclectic character of the Main Street Subdistrict.
    - 6) Sign materials and styles shall reflect the character of Old Town Keller. Post and bracket styles; wood, metal, or masonry materials with painted, engraved, or mounted letters are encouraged.
    - 7) Signs must be located on the facade in areas designated for this function; for example, a recessed or framed area or a parapet panel between shop-front and roofline.
    - 8) Color, materials, sizes, shapes, and lighting of signs must be compatible with the architecture of the building, the business it identifies and the character of the surrounding area.
    - 9) Sign shapes must be simple and straightforward to communicate well. Signs as symbols are permitted and encouraged because they are easily read and add to the vitality of a storefront.
    - 10) Portable signs such as menu boards for restaurants or to direct customers to parking areas shall be allowed provided they do not block sidewalks or streets and are stored indoors after hours of operation.
    - 11) Murals shall be considered on a case-by-case basis. Public murals shall be considered by the Public Arts Board for recommendation to and approved by the City Council. Private murals approval process includes a recommendation from the Planning and Zoning Commission to the City Council based on the following criteria:

- Shall not include any owner identification or commercial text message; however, it may contain graphics or images that relates to the products or services offered on the premises where the mural is located.
    - Murals or art representation displaying any owner identification or commercial text message will be considered as a "flat/wall sign."
  - Shall not depict nudity or obscene images and be generally acceptable for viewing by all audiences.
  - Materials utilized in painting a mural shall have proven durability and shall be maintained or removed if not maintained.
- 12) Temporary signs are allowed in accordance with the general sign provisions of this Code. (Amended by Ord. No. 1799 on July 5, 2016)
- f. *Parking Requirements.* Parking areas situated in front of buildings in new developments in the Main Street Subdistrict are prohibited. In new developments, required parking shall be provided at the rear of buildings. Parking provided on the side of a building will be considered on a case-by-case basis and approved by the City Council as an element of a site plan application. The parking requirements of this Code shall be enforced in new developments to the greatest extent possible. Developers must share in the cost of remote parking lots if all required parking cannot be provided on site.
6. *Development Standards - Neighborhood Subdistrict of Old Town Keller.*
- a. *Site Orientation and Layout.* The Neighborhood Subdistrict is more residential in character and contains a mixture of some of the early homes built in Keller and some infill residential structures from the 1900's through the 1970's. The structures in this subdistrict are set back farther from the street than the structures in the Main Street Subdistrict to allow for additional landscaping. Most of the streets have wide right-of-ways (approximately eighty feet [80']) that will accommodate ninety-degree (90°) head in parking within the street right-of-way (see Figure 5 within this Section).
- b. *Size of Lot.* Lots vary in size and dimension through the Neighborhood Subdistrict of OTK. Many of the structures built were designed to fit on narrow lots. Lot and yard sizes should be suitable to fit the character of the area and maintain health and safety as defined in the current building and fire codes.
7. *Design Standards - Neighborhood Subdistrict of Old Town Keller.*
- a. *Architectural Requirements.* All new structures of the Neighborhood Subdistrict shall resemble the residential character and style of a Texas small town of the early to middle 1900's (see Figure 4).  
Architectural styles considered appropriate include American foursquare, Craftsman, Bungalow, Minimal Traditional, and Ranch Style,  
Any buildings, in the form of new construction or being relocated from another location and having a non-residential-style architecture fitting the character of the district, may be considered in the Neighborhood subdistrict on a case-by-case basis and approved by the City Council as an element of a site plan application.
- b. *Landscaping, Lighting, and Sidewalk Requirements.*
- 1) *Street Trees.* A minimum of two large canopy trees shall be planted at suitable spacing, based on the type of tree, to accommodate mature canopy spread on center within the required front yard centered between the building and the property line. All trees and landscaping must be provided with adequate and inconspicuous irrigation systems.
- 2) *Ornamental Trees and Shrubs.* Ornamental trees and shrubs shall be planted in courtyards and in areas where space is limited near existing buildings. All new developments shall have foundation



---

plantings, either in ground, raised planters or pots, in front of the building and along any sides adjacent to public streets. The foundation planting area shall be a minimum of five feet (5') in width in ground, or of equal spacing if pots or raised bades are used, and contain a mixture of drought and heat tolerant ornamental trees, shrubs, and seasonal color.

- 3) *Streetlights, Parking Lot Lighting and Building Lighting.* The streetlight, parking lot lighting, building lighting and street furniture requirements for the Neighborhood Subdistrict are the same as the requirements for the Main Street Subdistrict.
  - 4) *Sidewalks.* Sidewalks in the Neighborhood Subdistrict shall be six feet (6') in width and constructed of concrete with a two-foot (2') wide band of pavers spaced every ten feet (10'). Paver's band shall resemble the brick paver sidewalks along Main Street.
- c. *Signage Requirements.*
- 1) The attached signage requirements for the Neighborhood Subdistrict are the same as the Main Street Subdistrict.
  - 2) Detached or Ground Mounted Signage.
    - a) All detached signage shall be externally illuminated.
    - b) A sign permit shall be required for all new signs or alterations to signs.
    - c) Only one detached sign shall be allowed per business per public street frontage.
    - d) For single-occupant buildings, detached signage shall not exceed fifteen (15) square feet in total surface area and six feet (6') in height. For multi-occupant buildings, all detached signage shall not exceed twenty-four (24) square feet in total surface area and six feet (6') in height.
    - e) Signs must reflect the character of Old Town and may include post and bracket or double-pylon signs using wooden posts or painted metal poles or monument style signs shall be allowed. Other styles that reflect the character of Old Town will be considered.
    - f) Sign materials shall be consistent with the character of Old Town and the primary licensed establishment.
    - g) Color, materials, sizes, shapes, and lighting of signs must be compatible with the architecture of the primary licensed establishment, the business it identifies and the character of the surrounding area.
    - h) Sign shapes must be simple and straightforward to communicate well. Signs as symbols are permitted and encouraged because they are easily read and add to the vitality of a storefront.
- d. *Parking Requirements.* As existing structures in the Neighborhood Subdistrict are redeveloped, the developer or property owner shall be responsible for constructing the ninety-degree (90°) head in parking within the right-of-way composed of either concrete or asphalt. The developer or property owner is also responsible for the construction of a concrete curb adjacent to the sidewalk and a concrete valley gutter between the street edge and the head-in parking space (see Figure 7 within this section for street cross-section). If head in parking does not provide an adequate number of parking for a particular use, parking may be added at the rear of the building if accessible, or the property owner may contribute funds for the construction of remote parking facilities. These requirements also apply to new developments.

#### OTK Zoning District Use Table

P = Permitted Uses

SUP = May Be Approved As Specific Use Permit

- = Not Permitted

Use	Neighborhood Subdistrict	Main Street Subdistrict
Administrative, professional or corporate office (Amended by Ord. No. 1805 on August 16, 2016)	P*/SUP	P*/SUP
Automobile electric charging station	P	SUP
Bakery (retail)	P	P
Bank, saving, loan, and credit unions, including automated teller	SUP	SUP
Bar	SUP	SUP
Barber shop or beauty salon stand alone	SUP	SUP
Barber shop or beauty salon within multi-use retail	P	P
Batching plant (temporary)	Permit	Permit
Bed and Breakfast/Tourist Home	SUP	-
Brewery with retail sales on and off premise	P	P
Brewery with entertainment inside or outside	SUP	SUP
Child Care (Center) as an accessory use only	SUP	SUP
Commercial wedding/event venue	SUP	SUP
Copy shop or printing shop	P	P
Dance studio or aerobics center	P	P
Distillery with 1,500 square-foot tasting room	SUP	SUP
Dry cleaning free-standing building	SUP	SUP
Entertainment Facilities (Indoor or Outdoor)	SUP	SUP
Grocery store or food market	SUP	SUP
Gunsmith (repair only)	SUP	SUP
Hotel	SUP	SUP
Kennels, Grooming Only	SUP	-
Light Manufacturing, wholly enclosed in a building	SUP	SUP
Medical Offices (Amended by Ord. No. 1805 on August 16, 2016)	SUP	SUP
Mixed-Use Residential	SUP	SUP
Museum or art gallery	P	P
Offices, City, County, State, and Other Governmental	P	P
Optical store, optician or optometrist	P	P
Pharmacist or drug store	SUP	SUP
Private club	P	P
Private park	SUP	SUP
Public parking garage (associated with building)	P	P
Public Park or Playground	SUP	P
Religious institution	P	P
Residential Single-Family Detached Dwelling	P	-
Residential Single-Family Dwelling: Townhome/Patio Home	-	SUP
Restaurant, café, cafeteria	P	P
Retail uses and services wholly enclosed within a building	P	P

Created: 2023-10-05 14:23:08 [EST]

(Supp. No. 35, Update 2)

Sales of used goods and merchandise	SUP	SUP
School, Private	SUP	SUP
Seasonal Sales	SUP	SUP
Spa to include Cosmetologists (Hair, Nails, Face) & Massage Therapists Licensed in TX	SUP	SUP
Studio, art or photographic (within multi-use retail)	P	P
Studio, art or photography (stand-alone)	P	P
Temporary field construction office	P	P
Utility structures (Private or Franchised)	SUP	SUP
Utility structures (public)	P	P
Veterinarian Clinic	SUP	P
Winery with retail sales (either on or off premise)	P	P
*Administrative, professional or corporate offices are allowed by right when on the second floor or higher of a building or when the use occupies 1,200 square feet or less in an existing building. In all other circumstances an SUP will be required. (Amended by Ord. No. 1805 on August 16, 2016)		

8. *Illustrations.*

Figure 1 - Old Town Keller Boundary

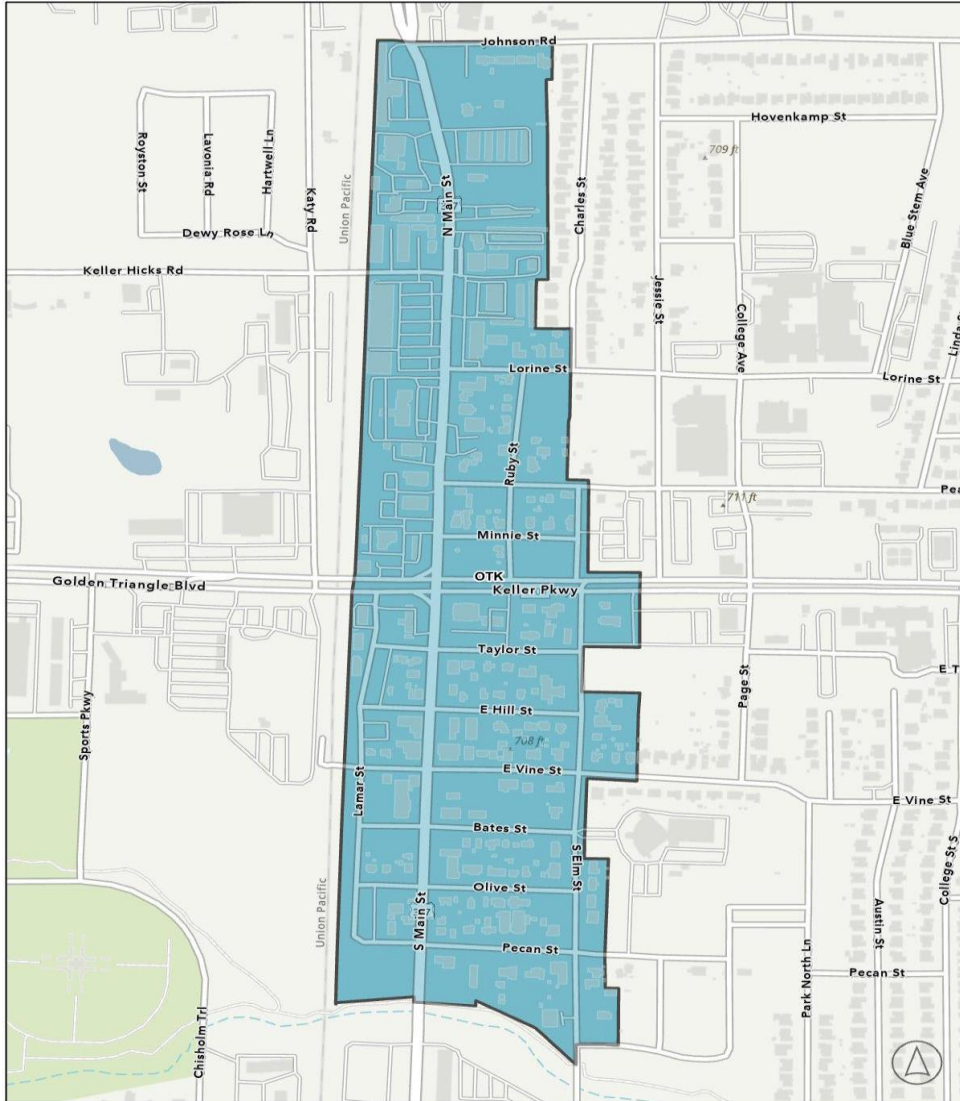

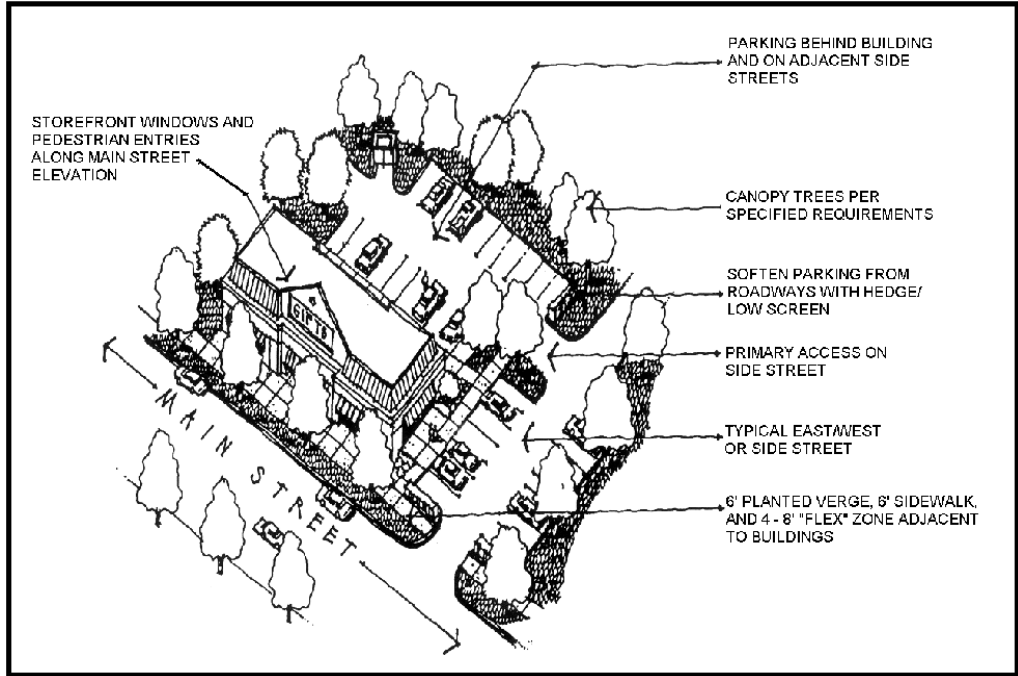

Figure 2 - Building Relationship to Main Street

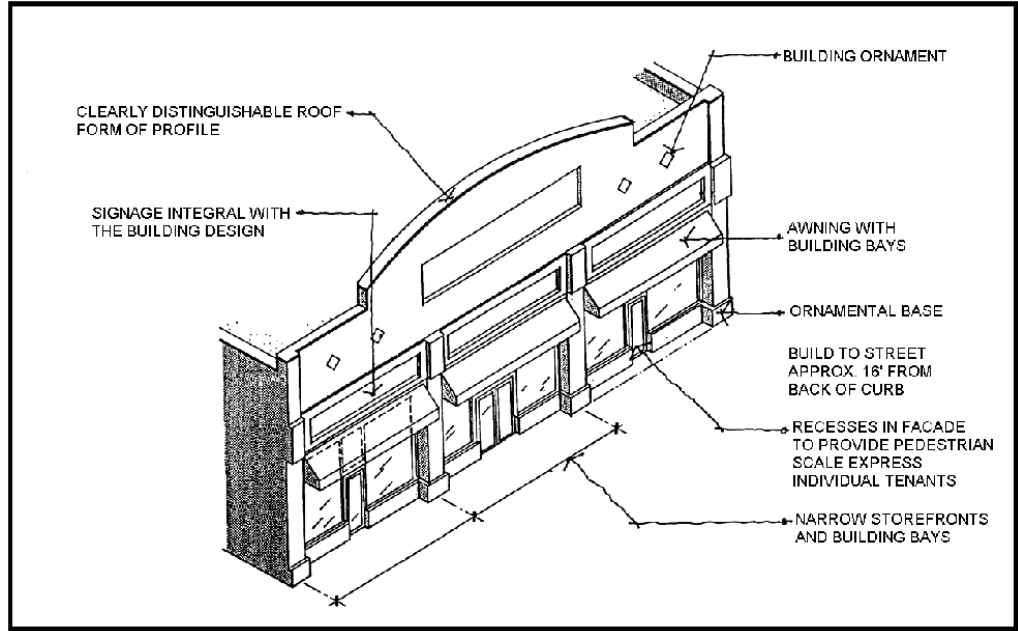

Figure 3 - Main Street Facade Treatments

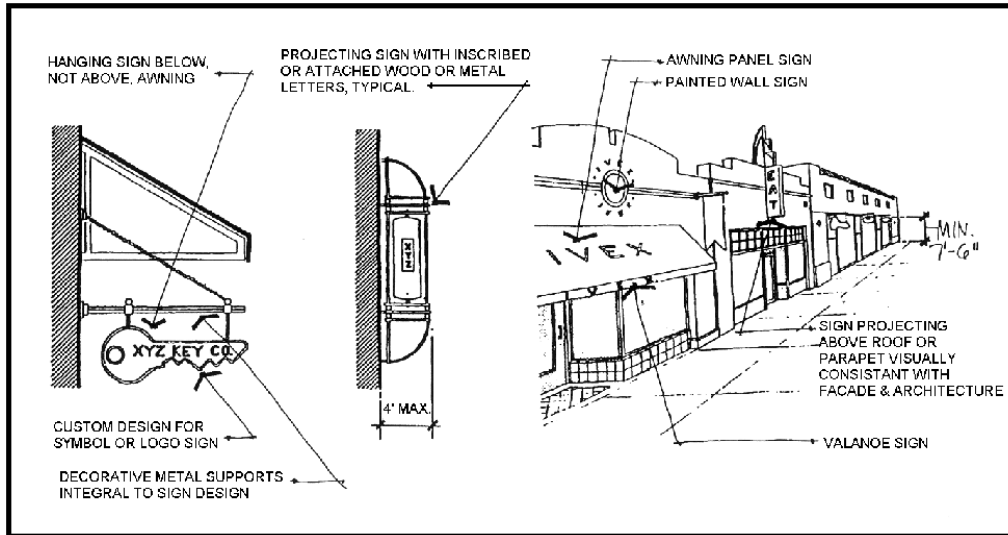

Figure 4 - Projecting Signs & View From Main Street

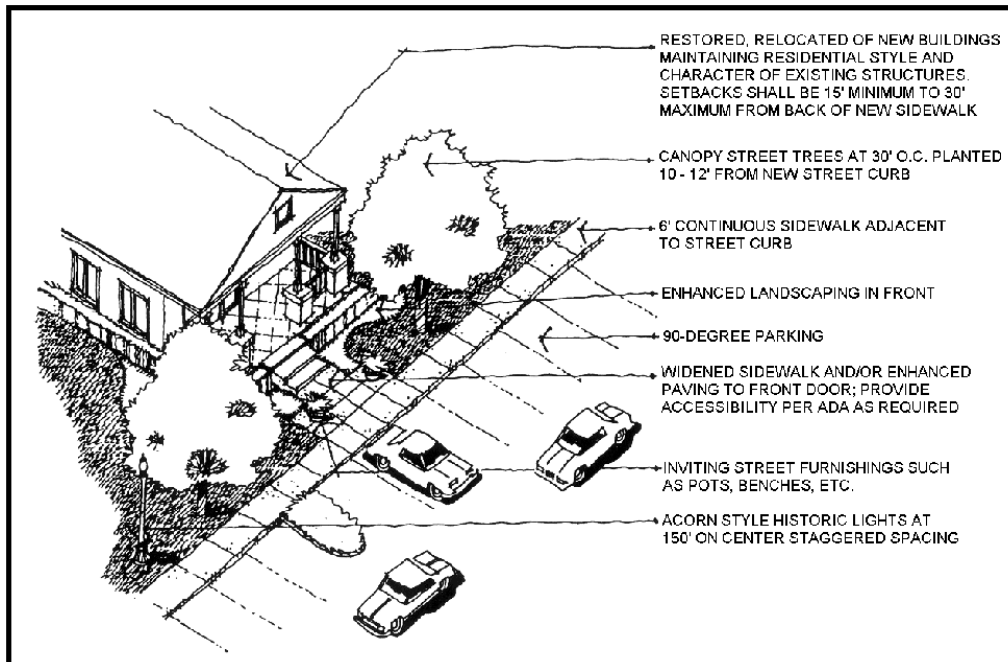
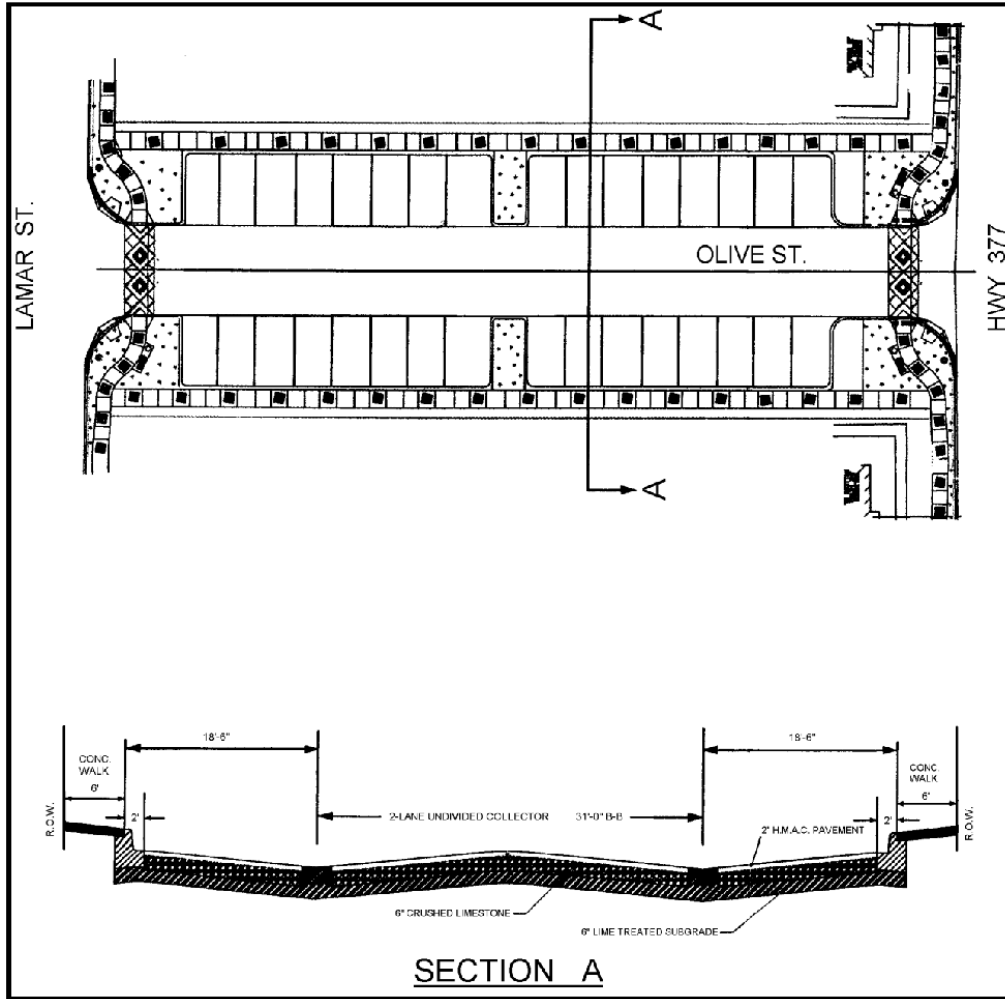

Figure 5 - Typical Neighborhood Street



**Figure 6 - Trash Receptacles and Street Furniture**



**Figure 7 - Typical Cross Section of Street in Old Town Keller**

(Ord. No. 1959 , § 2(Exh.B), 12-3-19; Ord. No. 2072 , § 2(Exh. A), 6-21-22; Ord. No. 2083 , § 2(Exh. A), 8-2-22; Ord. No. 2087 , § 2(Exh. A), 9-6-22; Ord. No. 2104 , § 2, 12-6-22; Ord. No. 2105 , § 2, 12-20-22)